



Trimble

2101

**Approach Plus
GPS Navigator**

Pilot Guide

Publication Number 82879



Trimble

2105 Donley Drive • Austin, TX 78758
(512) 432-0400



Trimble

2101

Approach Plus GPS Navigator

Pilot Guide

Publication Number 82879

Revision D

June 29, 1998

Software -240()

Trimble • 2105 Donley Drive • Austin, TX 78758
(512) 432-0400

No part of this manual may be reproduced in any form or by any means or used to make a derivative work (such as translation, transformation or adaptation) without permission from Trimble Navigation.

Copyright © 1997



2105 Donley Drive
Austin, TX 78758
(512) 432-0400

Limited Warranty



I. HARDWARE

TRIMBLE NAVIGATION, LTD. ("TRIMBLE"), 2105 Donley Drive, Austin, TX 78758, hereby warrants to the first retail purchaser only, that hardware purchased hereunder will be free from defects in material and workmanship for a period of two (2) years from the date of installation, not to exceed thirty (30) months from the date of shipment from TRIMBLE's factory. Should defects be found, TRIMBLE at its option, will repair or replace the product in which physical defects in materials or workmanship occur. The foregoing states the sole liability and obligation of TRIMBLE arising out of this warranty, and such warranty is subject to the following CONDITIONS AND LIMITATIONS.

(A) The defect shall occur under normal use and service for which this product was intended. TRIMBLE shall not be obligated or liable under this Warranty for defects which TRIMBLE's examination discloses are due to: (1) tampering, (2) misuse, (3) abuse, (4) neglect, (5) improper storage or maintenance, (6) use in a manner beyond which such equipment is normally intended to be used, (7) improper repair or poor workmanship by those who are not authorized by TRIMBLE to repair the products or use of defective material by such unauthorized persons, and (8) any other cause except for defects in material or workmanship caused by TRIMBLE.

(B) The warranty card supplied with the product must be completed and returned to TRIMBLE within 15 days of installation of the product in order for this Warranty to become effective.

(C) The product is sold and installed by an authorized dealer. A list of all authorized TRIMBLE dealers may be obtained from TRIMBLE.

(D) The company must have received a copy of a completed FAA Form 337 covering installation of the product in the purchaser's aircraft, or equivalent documentation showing installation of the product by the authorized TRIMBLE dealer.

(E) The product shall be returned to TRIMBLE via the dealer with transportation charges prepaid. After correction of the defects, the products will be returned to the purchaser, transportation charges prepaid, except for returns to purchasers in foreign countries, which purchasers shall be responsible for payment of such charges from the American Port of exit to purchaser's place of business. The risk of loss or damage to all products in transit shall be assumed by the party initiating the transportation of such products.

II. DATA

TRIMBLE warrants that the media on which the database is recorded will be free from defects in materials and workmanship under normal use for a period of two (2) years from the Delivery Date. Purchaser's sole and exclusive remedy, and TRIMBLE's sole and exclusive liability, under this warranty will be TRIMBLE's replacement of the media.

III. ITEMS NOT COVERED BY WARRANTY

EXCEPT FOR THE EXPRESS WARRANTIES GRANTED IN SECTIONS I AND II ABOVE, TRIMBLE MAKES NO OTHER WARRANTIES, EXPRESSED OR IMPLIED, WITH RESPECT TO ITS PRODUCT AND DISCLAIMS THE SAME. TRIMBLE MAKES NO EXPRESS OR IMPLIED WARRANTY WITH RESPECT TO THE DESIGN, ADEQUACY, ACCURACY, RELIABILITY, SAFETY OR CONFORMANCE WITH GOVERNMENT STANDARDS OR REGULATION OF ANY FLIGHT PROCEDURE PRESCRIBED BY A GOVERNMENT AUTHORITY, INCLUDING, BUT NOT LIMITED TO, ANY EXPRESS OR IMPLIED WARRANTY OF MERCHANTABILITY OR FITNESS FOR A PARTICULAR PURPOSE. FURTHER, TRIMBLE MAKES NO WARRANTY, EXPRESS OR IMPLIED, WITH RESPECT TO THE ADEQUACY, ACCURACY, RELIABILITY, SAFETY, OR CONFORMANCE WITH GOVERNMENT STANDARDS OR REGULATIONS, OF ANY INFORMATION CONTAINED IN THE PRODUCT WHICH IS PUBLISHED BY OTHERS OR WHICH TRIMBLE OBTAINED FROM OTHERS.

FURTHER, TRIMBLE MAKES NO EXPRESS OR IMPLIED WARRANTY WITH RESPECT TO THE COMPLETENESS OF ANY DATA, FLIGHT INFORMATION, OR FLIGHT PROCEDURE CONTAINED IN ITS PRODUCT. TRIMBLE DOES NOT INCLUDE ALL AVAILABLE DATA IN ITS PRODUCT.

IV. LIMITATIONS ON WARRANTY

THIS WARRANTY IS LIMITED TO THE ORIGINAL RETAIL PURCHASER, EXCEPT WHERE THE PRODUCT IS USED OR PURCHASED PRIMARILY FOR THE PURCHASER'S PERSONAL OR FAMILY USE, THIS WARRANTY IS IN LIEU OF ALL OTHER WARRANTIES EXPRESSED OR IMPLIED, INCLUDING WITHOUT LIMITATION, ANY IMPLIED WARRANTIES OF MERCHANTABILITY OR FITNESS FOR A PARTICULAR PURPOSE, IF ANY, AND SAID IMPLIED WARRANTIES ARE HEREBY EXPRESSLY EXCLUDED AND DISCLAIMED.

WHERE THE PRODUCT IS USED OR PURCHASED PRIMARILY FOR THE PURCHASER'S PERSONAL OR FAMILY USE, ANY IMPLIED WARRANTIES OF MERCHANTABILITY OR FITNESS FOR A PARTICULAR PURPOSE, IF ANY, ARE HEREBY EXPRESSLY LIMITED TO TWO (2) YEARS FROM THE DATE OF PURCHASE OF THE PRODUCT.

SOME STATES DO NOT ALLOW THE EXCLUSION OR LIMITATION OF AN IMPLIED WARRANTY, OR OF INCIDENTAL OR CONSEQUENTIAL DAMAGES, THEREFORE, THE ABOVE LIMITATIONS CONCERNING THE EXCLUSION OF IMPLIED WARRANTIES AND LIMITATIONS OF DAMAGES MAY NOT APPLY TO YOU. THIS WARRANTY GIVES YOU SPECIFIC RIGHTS, AND YOU MAY ALSO HAVE OTHER RIGHTS WHICH VARY FROM STATE TO STATE.

LIMITATION OF LIABILITY

TRIMBLE'S LIABILITY ARISING OUT OF THIS AGREEMENT SHALL NOT EXCEED THE AMOUNTS PAID BY YOU TO OBTAIN THE PRODUCT. TRIMBLE SHALL NOT BE LIABLE FOR SPECIAL, CONSEQUENTIAL, INCIDENTAL OR OTHER TYPES OF DAMAGES, INCLUDING WITHOUT LIMITATION, LOSS OF USE, LOST PROFITS, AND PERSONAL INJURY. TRIMBLE EXPRESSLY EXCLUDES AND DISCLAIMS SUCH DAMAGES RESULTING FROM OR CAUSED BY, THE USE, OPERATION, FAILURE, MALFUNCTION OR DEFECT OF ANY TRIMBLE PRODUCT, WHETHER OR NOT LIABILITY FOR SUCH DAMAGES IS DUE TO TORT (INCLUDING NEGLIGENCE), CONTRACT, WARRANTY, OR STRICT LIABILITY. THESE LIMITATIONS WILL APPLY EVEN IF TRIMBLE OR AN AUTHORIZED DEALER HAS BEEN ADVISED OF THE POSSIBILITY OF SUCH DAMAGE, AND NOTWITHSTANDING ANY FAILURE OF ESSENTIAL PURPOSE OF ANY LIMITED REMEDY. YOU ACKNOWLEDGE THAT THE AMOUNT PAID FOR THE PRODUCT REFLECTS THIS ALLOCATION OF RISK. SOME STATES DO NOT ALLOW THE LIMITATION OR EXCLUSION OF LIABILITY FOR INCIDENTAL OR CONSEQUENTIAL DAMAGES, SO THE ABOVE LIMITATION OR EXCLUSION MAY NOT APPLY TO YOU.

To obtain service under this warranty contact: Trimble Navigation Avionics Service at (512) 432-0400.

Purchase Date

Model Number

Serial Number

TRIMBLE 2101 Approach Plus

Insert latest change pages and destroy superseded pages.

LIST OF EFFECTIVE PAGES

Dates of Original and Change pages are:

Revision	A	July 7, 1997
Revision	B	August 25, 1997
Revision	C	November 14, 1997
Revision	D	June 29, 1998

Page Description	Page No.	Date
Title Page		June 28, 1998
List of Effective Pages	A - B	June 28, 1998
Record of Revisions	C	June 28, 1998
Table of Contents	i -iv	July 7, 1997
	v	June 28, 1998
	vi	July 7, 1997
	vii	June 28, 1998
	viii	July 7, 1997
Introduction	I-1 - I-6	July 7, 1997
	I-7	August 25, 1997
	I-8	July 7, 1997
Chapter 1 - Getting Started	1-1	July 7, 1997
	1-2	June 28, 1998
	1-3 - 1-5	July 7, 1997
	1-6 - 1-7	June 28, 1998
	1-8 - 1-12	July 7, 1997
	1-13	August 25, 1997
	1-14	July 7, 1997
Chapter 2 - Using the Navigator	2-1	July 7, 1997
	2-2	June 28, 1998
	2-3 - 2-10	July 7, 1997
Chapter 3 - Approaches	3-1 - 3-2	July 7, 1997
	3-3	November 14, 1997
	3-4 - 3-6	June 28, 1998
	3-7 - 3-22	July 7, 1997
Chapter 4 - The Waypoint Key	4-1 - 4-22	July 7, 1997
Chapter 5 - The Flight Plan Key	5-1 - 5-20	July 7, 1997
Chapter 6 - The Nav Key	6-1	July 7, 1997
	6-2 - 6-4	June 28, 1998
	6-5	July 7, 1997
	6-6 - 6-12	June 28, 1998
Chapter 7 - The Calculator Key	7-1 - 7-14	July 7, 1997
	7-15	June 28, 1998
	7-16 - 7-17	July 7, 1997
	7-18 - 7-20	June 28, 1998

TRIMBLE 2101 Approach Plus

Insert latest change pages and destroy superseded pages.

LIST OF EFFECTIVE PAGES

Dates of Original and Change pages are:

Revision	A	July 7, 1997
Revision	B	August 25, 1997
Revision	C	November 14, 1997
Revision	D	June 29, 1998

Page Description	Page No.	Date
Chapter 8 - The Auxiliary Key	8-1 - 8-13	July 7, 1997
	8-14	June 28, 1998
	8-15	July 7, 1997
	8-16	June 28, 1998
	8-17- 8-30	July 7, 1997
Chapter 9 - The Message Key	9-1 - 9-6	July 7, 1997
	9-7	November 14, 1997
	9-8	July 7, 1997
	9-9 - 9-10	June 28, 1998
	9-11	November 14, 1997
	9-12	July 7, 1997
Appendix A - Reference	A-1 - A-16	July 7, 1997
Appendix B - The GPS System: How It Works	B-1 - B-12	July 7, 1997
Appendix C - The User Setup Mode	C-1 - C-5	July 7, 1997
	C-6 - C-7	June 28, 1998
	C-8	July 7, 1997
	C-9 - C-10	June 28, 1998
	C-11 - C-12	July 7, 1997
Glossary	G-1	July 7, 1997
	G-5	June 28, 1998
	G-6 - G-8	July 7, 1997
Index	IND-1 - IND-10	June 28, 1998

TRIMBLE 2101 Approach Plus

RECORD OF REVISIONS							
Assigned To (Job Title)				Location			
Rev No.	Revision Date	Insertion Date	By	Rev No.	Revision Date	Insertion Date	By

Table of Contents

Introduction

The Navigator Functions	I-2
Safety First	I-3
Other Things You Should Know	I-4
Warranty Information	I-4
Service Information	I-4
Quick Reference Card	I-4
Installation Manual	I-4
Jeppesen Database - General Use	I-5
Jeppesen Database - International Use	I-5
Altitude Sources	I-6
Wind Calculation	I-6
About This Guide	I-7

1 Getting Started

1.1 The Navigator Components	1-2
1.2 The Jeppesen Navigation Database	1-3
1.2.1 NavData Card	1-6
1.3 The Power Switch	1-7
1.4 The LED Display	1-7
1.5 Operation Overview	1-8
1.5.1 Basic Operating Principles	1-11
1.5.2 The Internal Annunciator Lights	1-12

2 Using the Navigator

2.1 Power-Up 2-2
2.2 ENT Key 2-2
2.3 Data Selector Knobs 2-3
 2.3.1 Page Selection 2-3
 2.3.2 Data Entry 2-3
2.4 Direct-to Key 2-4
2.5 Mode Restore 2-5
2.6 Entering a Flight Plan 2-6

3 Approaches

3.1 What is a GPS Approach? 3-2
3.2 The Basic Rules of GPS Approaches 3-3
3.3 How to Select the Approach 3-4
3.4 How to Join an Active Approach in the Middle ... 3-7
3.5 How to Enable the Approach 3-8
 3.5.1 View APPROACH ENABLE Status 3-9
 3.5.2 Update the Baro Setting 3-9
 3.5.3 Disable the Approach 3-9
3.6 How to Perform a Course Reversal 3-9
 3.6.1 Procedure Turn Course Reversals 3-10
 3.6.2 Holding Pattern Course Reversals 3-11
 3.6.3 Teardrop Course Reversals 3-12
3.7 How to Fly a DME Arc Approach 3-12
3.8 Missed Approach 3-15
 3.8.1 Missed Approach Before the MAP 3-15
 3.8.2 Missed Approach Beyond the MAP 3-15
3.9 How to Fly a GPS Approach 3-16
3.10 RAIM 3-18
 3.10.1 RAIM Prediction 3-19
 3.10.2 RAIM Prediction on the Approach 3-21

4 The Waypoint Key

4.1	Waypoint Information	4-2
4.2	The Waypoint Displays	4-4
4.3	Selecting Airport, VOR, NDB, Intersection or User Waypoints	4-8
4.3.1	Select a Waypoint by Identifier	4-9
4.3.2	Select a Waypoint by City Name	4-9
4.3.3	Select a Waypoint by Waypoint Name	4-10
4.3.4	Scan Waypoint Identifiers	4-10
4.4	Selecting Approach, SID, and STAR Procedures	4-11
4.4.1	To Fully Define a Procedure	4-13
4.4.2	To Select a Procedure Name	4-13
4.4.3	To Select a Transition	4-14
4.5	Activating a Waypoint or Procedure from WPT	4-14
4.5.1	Selecting Direct Steering to Waypoint in WPT	4-14
4.5.2	Activating a SID or STAR Procedure ...	4-15
4.5.2.1	Select Direct to the First Waypoint	4-15
4.5.2.2	Join a Leg of the Procedure	4-15
4.5.2.3	Direct-to Any Waypoint in the Procedure	4-16
4.6	User Waypoints	4-17
4.6.1	Creating a User Waypoint	4-17
4.6.2	Editing a User Waypoint	4-19
4.6.3	Erasing a User Waypoint	4-19
4.7	Activating an Approach Procedure	4-20
4.7.1	Select Direct-to the First Approach Waypoint	4-20
4.7.2	Join a Leg of the Approach Procedure	4-20
4.7.3	Direct to Any Waypoint in the Approach Procedure	4-21
4.7.4	Fly Direct to the FAF	4-21
4.7.5	Intercept the Final Course Inbound	4-22

5 The Flight Plan Key

- 5.1 Flight Plan Modes 5-2
- 5.2 Entering Waypoints and Procedures 5-4
- 5.3 Building a Flight Plan 5-6
 - 5.3.1 Adding a Waypoint by Identifier 5-6
 - 5.3.2 Adding a Waypoint Using WPT 5-7
 - 5.3.3 Adding a Waypoint Using NRST 5-7
 - 5.3.4 Adding a Procedure 5-8
- 5.4 Editing a Flight Plan 5-9
 - 5.4.1 Insert, Replace or Delete Waypoints ... 5-10
 - 5.4.2 Insert a Procedure 5-10
 - 5.4.3 Replace or Delete a Procedure 5-12
 - 5.4.4 Editing a SID or STAR Procedure 5-12
- 5.5 Review Legs of a Flight Plan 5-13
- 5.6 Reversing a Flight Plan 5-14
- 5.7 Activating a Flight Plan 5-14
 - 5.7.1 Join a Flight Plan Leg 5-14
 - 5.7.2 Direct-to a Flight Plan Leg 5-15
- 5.8 Canceling an Active Flight Plan 5-15
- 5.9 Erasing a Flight Plan 5-16
- 5.10 Nearest Waypoints and Agencies 5-17
- 5.11 Holding Patterns 5-18
 - 5.11.1 Holding at a FPL Waypoint 5-18
 - 5.11.2 Holding Outside of a Flight Plan 5-18
 - 5.11.3 Holding After a Missed Approach 5-19

6 The NAV Key

6.1 NAV Mode 6-2

6.1.1 NAV Displays 6-3

6.1.2 Advisory Waypoint 6-4

6.1.3 The Time Display 6-5

6.1.4 The Vertical Navigation Display 6-6

6.2 Ground Track Displays 6-7

6.2.1 Track Error Graphic Display 6-7

6.2.2 CDI Display 6-9

6.2.2.1 Cross-Track Errors – Ground Track 6-9

6.2.2.2 CDI Scale 6-10

6.3 Waypoint Information Mode 6-11

7 The Calculator Key

7.1 Entering Data in the CALC Mode 7-2

7.2 Flight Plan/Fuel Pages 7-2

7.2.1 Time, Distance and Speed Calculations 7-3

7.2.2 Fuel Management Calculations 7-4

7.2.3 Fuel Remaining Page 7-6

7.2.4 Fuel At Arrival Page 7-7

7.2.5 Minimum Fuel Page 7-7

7.2.6 Total Fuel Used Page 7-8

7.2.7 Engine Fuel Flow Page 7-9

7.3 Air Data Pages 7-10

7.3.1 Pressure Altitude Calculations 7-10

7.3.2 Density Altitude Calculations 7-11

7.3.3 True Airspeed (TAS) Calculations 7-12

7.3.4 Winds Aloft Calculations 7-14

7.3.5 Crosswind and Head Wind
Calculations 7-16

7.4 Saving the Present Position 7-17

7.4.1 Copy a Phonetic Waypoint 7-17

7.5 Vertical Navigation Profiles 7-18

8 The Auxiliary Key

- 8.1 The Checklist Mode 8-3
 - 8.1.1 Creating and Naming Checklists 8-3
 - 8.1.2 Using a Checklist 8-5
 - 8.1.3 Editing a Checklist 8-6
 - 8.1.4 Inserting and Deleting Checklist Items.. 8-7
 - 8.1.5 Deleting a Checklist 8-9
- 8.2 The System Status Mode 8-10
 - 8.2.1 The Date/Time Display 8-10
 - 8.2.2 The Present Position Display 8-12
 - 8.2.2.1 The Altitude Display 8-12
 - 8.2.2.2 Entering Manual Altitude 8-14
 - 8.2.2.3 Pressure Altitude and GPS
Altitude 8-14
 - 8.2.3 The Voltage and Temperature Display . 8-15
 - 8.2.3.1 The Crystal Offset and Memory
Battery Display 8-15
 - 8.2.3.2 The GPS Antenna Display 8-16
 - 8.2.4 The Database Expiration Display 8-16
 - 8.2.5 The Software Revisions Display 8-17
 - 8.2.6 The System Code Display 8-17
- 8.3 The Sensor Status Mode 8-18
 - 8.3.1 GPS Sensor Status 8-18
 - 8.3.2 Estimated Accuracy 8-20
 - 8.3.3 GPS Satellites Tracked Display 8-21
 - 8.3.4 GPS Satellite Status Display 8-21
 - 8.3.4.1 Satellite Database 8-22
 - 8.3.5 GPS Sensor Reset 8-23
 - 8.3.6 GPS Satellite Availability 8-24
 - 8.3.7 Approach RAIM Availability 8-25
- 8.4 The Configure Mode 8-26
 - 8.4.1 Selecting a Parallel Offset 8-26
 - 8.4.3 The Dead Reckoning Display - Demo
Mode 8-28
 - 8.4.4 The Display Diagnostic Page 8-30
- 8.5 User Setup Mode 8-30

9 The Message Key

9.1 Accessing Messages	9-2
9.2 System Messages	9-4
9.3 Advisory Messages	9-7
9.3.1 Database Advisory Messages	9-7
9.3.2 Flight Plan Advisory Messages	9-8
9.3.3 Approach Advisory Messages	9-9
9.3.4 Parallel Track Advisory Messages	9-9
9.3.5 Fuel Management Advisory Messages	9-10
9.3.6 AIRWATCH™ Advisory Messages	9-11
9.3.7 Other Advisory Messages	9-11

Appendix A - Reference

Appendix B - The GPS System: How It Works

Appendix C - The User Setup Mode

Glossary

Index

TRIMBLE 2101 Approach Plus

This page intentionally left blank.

Introduction

The Trimble 2101 Approach Plus GPS Navigator is a powerful navigation management system designed for simple operation. The Trimble 2101 Approach Plus calculates your position in three dimensions: latitude, longitude and altitude. It uses Global Positioning System (GPS) satellites, is completely automatic, and requires no initialization.

Your Trimble 2101 Approach Plus uses a state of the art, DZUS rail-mounted design, and features:

- A twelve-channel GPS receiver that calculates position and monitors signal integrity.
- Direct access to worldwide data on Airports, Approaches, SIDs, STARs, VORs, NDBs, Intersections, and special use airspaces on the Jeppesen database card used by the Navigator.
- Push-button and knob-select functions that are simple and consistent, making them easy to learn and remember. Its annunciator lights clearly show your unit's mode of operation and any messages it issues.

TRIMBLE 2101 Approach Plus

The Navigator Functions

The Trimble 2101 Approach Plus performs a wide variety of navigation functions.

<i>Direct Navigation</i>	Designate a destination and fly directly to it from any position.
<i>Flight Plan Navigation</i>	Define a flight plan with up to 40 waypoints and be guided automatically along the selected route.
<i>Position Finding</i>	Determine current position in terms of latitude and longitude or bearing and distance from any point.
<i>ETA/Fuel Consumption</i>	Monitor a flight's progression and determine accurately the time of arrival and fuel consumption.
<i>Emergency Navigation</i>	Determine the nearest Airport, VOR, NDB, or Agency with the press of one button.
<i>Controlled Airspace</i>	Receive immediate notification if the aircraft is approaching a controlled airspace, or if a selected flight plan leg enters a controlled airspace.
<i>Preflight Planning</i>	Determine the distance and bearing to destination, distance and bearing of any leg, total flight plan distance, and other useful information before departure.

Navigator Functions

Access information or perform calculations, including waypoint data (such as airport communication frequencies, runway lengths, and approach type), estimated time enroute and time of arrival, ground track and ground speed, minimum safe altitude, minimum enroute safe altitude, desired and actual tracks, winds aloft, fuel range, true air speed, and density altitude calculation.

Safety First

Trimble has designed and built the Trimble 2101 Approach Plus with all possible care. Many factors, however, can affect aircraft safety. Please observe the following precautions.

Follow the fundamental rule of aircraft navigation: NEVER RELY ON A SINGLE NAVIGATION SYSTEM! Errors or malfunctions are always possible in any system, and double-checking navigation information should be a standard procedure.

Maintain the Trimble 2101 Approach Plus and other equipment properly to ensure that it operates according to specifications.

Update the Jeppesen database card regularly for the most current information. Jeppesen issues an update approximately every 28 days. See the Jeppesen subscription packet enclosed with the Trimble 2101 Approach Plus or refer to the subscription form in this manual for information on subscribing to this update service.

The Trimble 2101 Approach Plus has a wealth of features and information. But remember the most important rule of flight: SEE AND BE SEEN.

TRIMBLE 2101 Approach Plus

Other Things You Should Know

Warranty Information

Be sure to fill out and return the Registration and Warranty Card as soon as you purchase your unit. The tear-out card is located at the front of this guide. When you return this card, we will send you a complimentary copy of Trimble's *GPS: A Guide to the Next Utility*.

Service Information

Authorized service for your Trimble 2101 Approach Plus is available by returning the unit to Trimble or a Trimble-authorized repair center. Any customizing of the unit will be erased during system servicing (i.e., Serial Setups, Flight Plans, User Waypoints, Personal Messages). If you have purchased the optional flight planning and configuration software, be sure to save your customized settings so they can be restored when the unit is returned to you. To return the unit directly to Trimble, send it to:

Trimble
2105 Donley Drive
Austin, Texas 78758
Attn: Service Department
Phone: (512) 432-0400
FAX: (512) 836-9413

Quick Reference Card

A Quick Reference Card is included with this guide. The card summarizes the steps required to perform frequently used Navigator functions. Once you become familiar with the operation of your Trimble 2101 Approach Plus, this card will be a helpful reminder.

Installation Manual

Installation information for your Trimble 2101 Approach Plus is contained in a separate Installation Manual that came with the unit. The person who installs your Navigator—probably your dealer—will use this manual to install the unit in your aircraft.

Jeppesen Database - General Use

The navigation database used with the Navigator is produced by Jeppesen NavData Services. The International database card provides access to data on Airports, VORs, NDBs, Intersections, and Airspace Boundaries. The North American database card also includes MSAs. Both the North American (part number 81461-10) and International database (part number 81461-11) cards are required for complete worldwide information.

This database information is quite reliable. However, NDB and intersection identifiers are not unique! There are about 120 NDB and Intersection identifiers that are repeated anywhere from 2 to 5 times in the Jeppesen database. Therefore, it is important to double check waypoint information.

Users finding incorrect information in the database are encouraged to call Jeppesen NavData Services at (303) 799-9090 and report a Trimble database problem.

This guide includes additional information about database features in the section where they are introduced.

Jeppesen Database - International Use

Database coverage for International airspaces is limited. For example, there are no UNI frequencies available in the International database. Also, information on Restricted Airspaces and MSAs is not currently available for International airspaces. Contact Jeppesen NavData Services for complete information on International coverage.

TRIMBLE 2101 Approach Plus

Altitude Sources

The Trimble 2101 Approach Plus accepts altitude data from an encoding altitude serializer.

Wind Calculation

The Trimble 2101 Approach Plus automatically computes winds aloft when provided both heading and TAS from a Shadin ADC-200.

The Navigator is compatible with the ADC-200 Air and Fuel Data Computer, produced by the Shadin Co., Inc., which supplies fuel flow, pressure altitude, outside air temperature, and indicated air speed to the Navigator for the calculations. When coupled with an air and fuel data computer, the Trimble 2101 Approach Plus can automatically calculate:

- fuel remaining
- flight time remaining
- fuel to destination
- fuel efficiency
- fuel consumed
- density altitude
- true airspeed
- wind direction
- wind speed
- crosswinds

About This Guide

This guide is designed to get you up to speed as quickly as possible using the Trimble 2101 Approach Plus.

This manual is valid for the software version indicated on the title page. An alpha character in the parentheses indicates a minor modification to the initial software release. Revisions are indicated with the letters A-Z. For example, 240(A) is a revision to software version 240.

Chapter 1, *Getting Started*, is an introduction to the Trimble 2101 Approach Plus, including physical descriptions of components, their uses and functions.

Chapter 2, *Using the Navigator*, contains basic operating instructions for data entry, direct-to, and flight plan activation.

Chapters 3-9 include detailed information on the Trimble 2101 Approach Plus modes, displays, and functions.

The Appendices include detailed information about GPS technology and are followed by a glossary and an index.

You may also wish to use the Trimble 2101 Approach Plus's Demo capability, which lets you try out many of the unit's functions while on the ground. Instructions for using the Demo feature are in Chapter 8.

TRIMBLE 2101 Approach Plus

This page intentionally left blank.

Chapter 1

Getting Started

The Trimble 2101 Approach Plus GPS Navigator is a powerful navigation management system designed for simple operation. Chapter 1 introduces the user to the primary components and the major functions of the Trimble 2101 Approach Plus GPS Navigator.

This chapter covers:

- Information Displays
- Keys
- Selector Knobs
- Annunciator Lights

TRIMBLE 2101 Approach Plus

1.1 The Navigator Components

The front panel of the Trimble 2101 Approach Plus GPS Navigator includes six components:

- Jeppesen database card slot
- A power switch
- The LED display
- The function keys
- Two selector knobs
- Annunciators

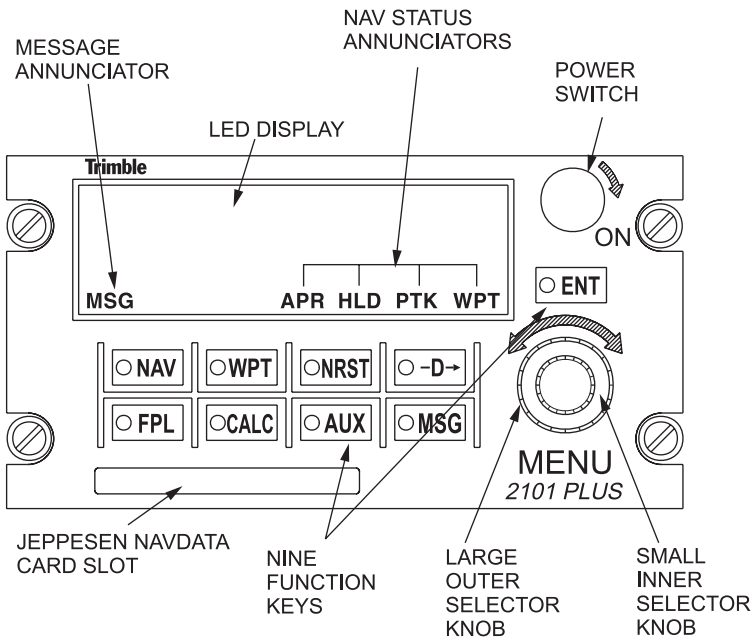

82879-001

1.2 The Jeppesen Navigation Database

The Navigation Database, produced by Jeppesen NavData Services, is a sophisticated product, providing access to reliable, worldwide data on Airports, Approaches, SIDs, STARs, VORs, NDBs, Intersections, and Airspace Boundaries. The North American and International database cards together provide complete worldwide information. The NavData Database Card contains the following information (see exceptions below on the International Database Card):

Reported Public-Use Airports and Military Bases with Runways of 2000 Feet or Greater

- Identifier, City Name, State/Country, Facility Name
- Runway Number, Length, Width and Surface Type (Hard, Gravel, Turf, or Soft), Traffic Pattern Direction
- Field Elevation and Beacon Availability
- Lighting Availability on at Least One Runway
- IFR Approach, Aircraft Services Availability
- ATIS, Approach, Tower, Ground, CTAF and Unicom Frequencies (when multiple frequencies exist, only one is given). Range of 118.00 to 136.975 for Com frequencies.
- Latitude and Longitude

Approaches

- Airport Identifier associated with Approach
- Approach Name (with Runway when applicable)
- Initial Approach Fixes (IAFs) and Transitions
- DME Arcs
- Approach Waypoints with Type Identifiers (IAF, FAF, MAP, MAHP, Intermediate Waypoints)
- Latitude and Longitude of Approach Waypoints

TRIMBLE 2101 Approach Plus

Standard Instrument Departures

- Airport Identifier associated with SID
- SID Name
- Applicable Runways
- SID Transitions
- SID Waypoints
- Latitude and Longitude of SID Waypoints

Standard Terminal Arrivals

- Airport Identifier associated with STAR
- STAR Name
- STAR Transitions
- STAR Waypoints
- Latitude and Longitude of STAR Waypoints VORs and NDBs
- Identifier, City Name, State/Country, Facility Name
- Frequency (range of 180 to 713 KHz for NDBs; range of 108 to 117.95 for VOR frequencies) and Morse Code for identifier
- Latitude and Longitude

Intersections

- Name and Region
- Latitude and Longitude

Minimum Safe Altitudes

Controlled Airspace Advisories and Frequencies

- Nearest Controlling Agency and Frequency (when multiple frequencies exist, only one is given)

Note that the International NavData Database Card does not contain Unicom frequency information, nor Minimum Safe Altitudes.

Information provided is as reported by governing agencies and Jeppesen. The database information is provided as a reference and is not to be solely depended upon for navigation communication, takeoff, landing, or guidance. Depending on the reporting agency, some information may be missing or inaccurate. Also, the International Database may be missing certain classes of data and does not contain minimum safe altitudes. Always check local agency documents for full and correct information.

CAUTION

When executing terminal area procedures (SIDs, STARs and Approaches), note that the Navigator database will contain all the waypoints associated with those procedures, but not necessarily all the legs. For example, a missed approach procedure may require the pilot to fly runway heading to 3000 feet, then turn left to intercept an inbound course to the Missed Approach Holding Point (MAHP). For this procedure, the navigator will have only the identifier and coordinates of the MAHP, not the procedures for arriving at it. The pilot should always consult the appropriate publication to ensure the procedure is flown correctly.

TRIMBLE 2101 Approach Plus

1.2.1 NavData Card

Insert the card into the Navigator with the gold contacts facing up. The card will slide smoothly into the slot when properly inserted. If it does not, remove the card and verify the orientation.

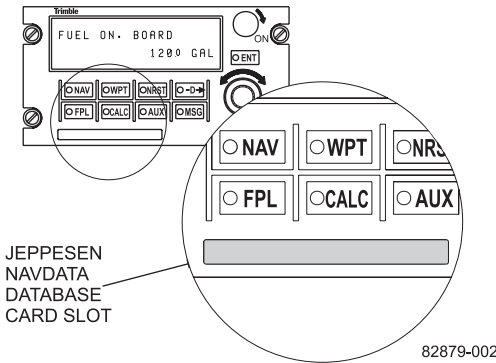

The NavData card supplied with your Navigator was current when the unit was shipped from the factory. The data on the card is updated every 28 days by Jeppesen, so it is important to monitor the expiration date. To receive database updates, complete the subscription form enclosed with the system or use the form located in the front of this guide.

If the card is not present at power-on, you will receive a “DATA-BASE MISSING” message. If the card has expired you will get a “DATABASE EXPIRED” message.

WARNING

Removing the data card with power applied cancels the active flight plan. The Navigator displays the message

DATA CARD REMOVED
REPLACE TO RESTART

DATA CARD REMOVED
FPL CANCELLED

until a card is reinserted, at which time the unit restarts.

1.3 The Power Switch

The Navigator has one power switch, located at the top of the unit. To activate the unit, turn the power switch to the ON position.

When the power is turned on, the Navigator performs self-diagnostic tests and begins its automatic position initialization. When these tests are completed the Fuel on Board message appears. Refer to Section 2 for information on completing initialization.

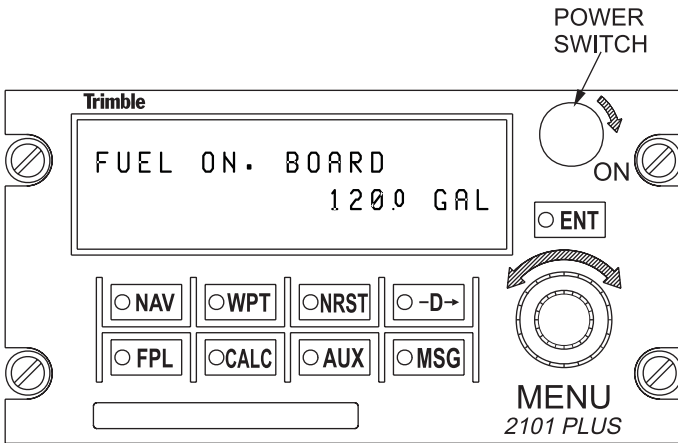

82879-003

1.4 The LED Display

The Navigator displays information on a two line LED screen. The displayed information varies, depending on the selected mode. For example, a typical NAV mode display looks like this:

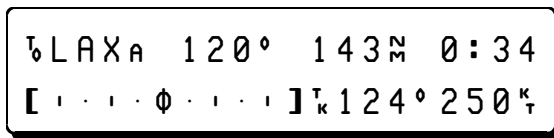

The top line of the display indicates that to the Los Angeles Airport, bearing is 120°; distance is 143 nautical miles; estimated time en route is 34 minutes. The bottom line indicates that the CDI is centered; current track is 124°; current ground speed is 250 knots.

TRIMBLE 2101 Approach Plus

The LED screen features automatic dimming. The screen intensity is automatically adjusted based on the ambient light.

1.5 Operation Overview

The pilot controls the operation of the Navigator with the KEYS and the SELECTOR KNOBS. ANNUNCIATOR LIGHTS alert the pilot of system messages, current navigation mode, and parallel track selection.

- The Mode Keys select a major function category.
- The Function keys provide specific operations.
- The Selector knobs are used to control the display and modification of information.

Mode Keys, Modes, Knobs, and Data Pages

The Navigator's operation is organized into MODES, FUNCTIONS, and DATA PAGES. You may access these functions using the keys and knobs.

A Mode Key provides access to the navigator's modes, or states. The nine keys are:



The navigation key is used to view navigation and position information along your selected route.



The waypoint key is used to view information such as bearing and distance, runway, name, frequencies, and position.



The flight plan key is used to view the active flight plan, stored flight plans, and to build and edit flight plans.



The calculator key enables you to perform fuel and airdata computations.



The auxiliary key is used for a variety of functions. Use it to view system information such as date, time, and GPS receiver status. Use it to view your custom checklist, set a parallel track offset, and select data base search regions.



The nearest key is used to view information about the 20 nearest airports, approaches, VORs, Agencies, NDBs, intersections, and user waypoints.

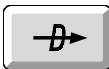

The direct-to key is used to change your flight path. Use it to fly direct to any waypoint in the data base and to activate a flight plan.



The message key is used to view system messages and to display your current CDI scaling.



The enter key is used for data entry. Press it to obtain a flashing cursor in an editable data field.

The Selector knobs are used to control the display and edit information.



The small, inner knob is used to change the top line of the display or to change data under the cursor.



The large, outer knob is used to change the bottom line of the display, to advance the cursor within a data field, and to advance the cursor between data fields.

TRIMBLE 2101 Approach Plus



A key may have one or more modes. The Navigator displays mode names bracketed by asterisks. For example, the System Status mode of the AUX key is displayed as *SYSTEM STATUS*.

A mode may have one or more DATA PAGES. Data pages may display status information about the Navigator, or contain data fields that may be edited.

A data page may also have additional information displayed either on a secondary data page or on the upper or lower line of the current page.

Selecting Keys, Modes, and Data Pages

When pressed, the key lights to indicate that it is the active key, and one of the modes of that key is displayed. Pressing the key again displays the next mode, and so on. When the last mode is reached, pressing the key again will cycle back to the first mode.

If the displayed mode contains data pages, then rotating the  sequences through the data pages. If a data page has additional information related to the current data page, this may be displayed by turning the . The additional information may be a secondary data page, or another line of data on the current data page.

When the last data page is reached, rotating the  in the opposite direction sequences back through the data page, or to another line of data on the current data page.

1.5.1 Basic Operating Principles

The following principles apply to all Navigator functions:

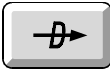

(1st Press)

Selects displayed Waypoint, Procedure, or Flight Plan for activation.



(2nd Press)

Activates course steering as selected (abort by pressing the NAV key).



(1st Press)

Opens any editable field on displayed page.



(2nd Press)

Accepts entered data.



Press a key (NAV, WPT, FPL, CALC, AUX, NRST) multiple times to select desired mode. Hold for 1 to 1½ seconds to return to Primary page of key.



(small, inner selector knob)

Use the small, inner selector knob to:

- Change any editable field (course, distance, or procedure) located within angle brackets "< >."
- Change alphanumeric or available option/function of selected field while editing.
- Scroll through Primary pages and top lines of displayed mode.











(large, outer selector knob)

Use the large, outer selector knob to:

- Move between editable fields on displayed page.
- Scroll through Secondary pages and bottom lines of displayed mode.

Entering Information

Some data pages contain editable fields. The   and  key are used to enter or change information on a data page. To do this:

- Rotate the  to select the desired data page of the active function.
- Press  to initiate editing.
- Rotate the  to move within the data field.
- Rotate the  to edit information in the data field.
- Press  to complete the data entry.

1.5.2 The Internal Annunciator Lights

The internal Annunciator Lights are located below the LED display. They are visible only when lit.

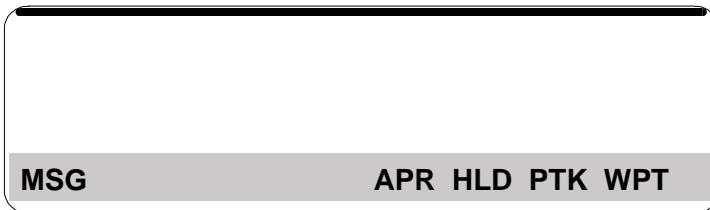

MSG

The MSG annunciator light flashes when there is a message to view. If there are multiple messages that you have not yet viewed, the light continues to flash until all messages have been viewed. After all the messages have been viewed, the MSG annunciator light stops flashing. If the condition that caused the MSG remains, the MSG annunciator remains illuminated.

CDI scaling settings are always available under the MSG key.

If the Navigator is wired to your audio panel, you will hear a beeping tone anytime the MSG annunciator is flashing.

(Details of the various Navigator messages are presented in Chapter 9.)

WPT

The Waypoint annunciator light alerts you to waypoint arrival. When approaching the active waypoint, the light will illuminate with the lead time as determined by the sum of the selected lead time and the computed turn anticipation time. Lead time is set using the Auxiliary key, Configure mode, with the factory set default equal to 10 seconds. Turn anticipation time is computed by the Navigator based on the course difference between the current leg and the next leg, assuming a standard rate of turn. If the waypoint is the last waypoint, turn anticipation time is zero.

PTK

The Parallel Track annunciator is on when you have selected a track parallel to the current leg's track. Press the key to view the selected offset.

HLD

The Hold annunciator light alerts the pilot that the Active Flight Plan is suspended at the current Active Waypoint

APR

The Approach Annunciator comes on at 2 nm inbound to the Final Approach Fix (FAF) when all Approach requirements are met. The requirements are: an Approach Profile is Activated, Approach mode is Enabled, Approach RAIM is predicted to be available at the FAF and MAP, and the aircraft is located between the FAF (from 2 nm inbound) and the MAP at or near the final approach course.

NOTE:

The RAIM and GPS internal annunciator lights have no function in software versions -240 and higher.

TRIMBLE 2101 Approach Plus

This page intentionally left blank.

Chapter 2

Using the Navigator

The Navigator operating procedures are designed to minimize the pilot memory items and to behave consistently across all operating modes and pages. This manual uses the following naming conventions for repetitive items.

Navigator	Refers to the Trimble 2101 Approach Plus Navigator.
Selector Knobs	Refers to the two concentric knobs on the face of the Navigator.
Key	Refers to any of the keys on the face of the Navigator.
Mode	Navigator functions accessed by pressing a key.
Page	Data within a function, accessed by rotating the knobs.
Waypoint	A single point, such as a VOR, NDB or Airport.
Procedure	A collection of waypoints such as SIDs or STARs and Approaches.

TRIMBLE 2101 Approach Plus

2.1 Power-Up

To activate the Trimble 2101 Approach Plus GPS Navigator, rotate the power switch located at the right side of the unit. The Navigator automatically executes a self-test, displaying the results on the screen.

As part of the self-test process, the Navigator performs a lamp test that illuminates:



- all internal annunciators
- all external annunciators
- all keys

When the self-test is complete, the Navigator displays the last computed fuel quantity value.

- If the value is correct, press any key to begin Navigation.
or
- If the fuel value is incorrect, use the selector knobs to enter the correct value.
- Press  to complete the entry.

2.2 ENT Key

The  key is used to begin and end all data entry.



- Press  to open a field.
- Use the Data Selector Knobs (described next) to change or select the data.
- Press  to close the field.

2.3 Data Selector Knobs

The concentric selector knobs have two operating modes: page selection and data entry.



2.3.1 Page Selection



Most Navigator modes have more than one page of data available. Rotate the small knob to go from page-to-page. Use both knobs to change the top and bottom display lines.

- Use the  knob to change the top line of the display.
- Use the  knob to change the bottom line of the display.

2.3.2 Data Entry

Data selection is accomplished using the  key and the selector knobs.

- Use the  knob to move the cursor within a field and to move from field to field.
- Use the  knob to change the data under the cursor.
- Press the  key to complete the entry.

Some data fields, such as procedure names, have chevrons (<>) around them. You may change the data in these fields by simply rotating the  knob. You do not need to press  to open and close the field; although that also works.

TRIMBLE 2101 Approach Plus

2.4 Direct-to Key



The  key is used to change your flight path. Use this key to fly direct-to any waypoint in the data base, enter a holding pattern, and to activate a stored flight plan.



This key requires two consecutive presses to change your flight path. After the first press, review the data on the display screen. Note the proposed course and waypoint. Change the course as desired (course for a “join leg” is fixed by the leg waypoints and cannot be changed). For reference, set your CDI or HSI to the proposed course. Once you are satisfied with the proposed flight path change, press the key a second time to execute the change. The Navigator will automatically change to the Primary Navigation page.

Use  to set course



If you did not change the course offered by the Navigator after the first  key press, the Navigator centers the CDI. If you selected a course to/from the waypoint, the Navigator will deflect the CDI as appropriate to the aircraft’s position relative to the selected course.

Press  instead of the second  press to abort without changing your flight path.

If you select direct-to a waypoint from a waypoint mode while you are on an active flight plan, the navigator will cancel the flight plan on the second  press. In this circumstance, notice the display after the first  press contains the phrase “...& CANCEL FPL”.

To change your flight path:



- Select a waypoint from **WPT**, from **NAV**, or a flight plan from **FPL**.
- Press **-D>**.
- To change the course, use the  knob.
- Set your CDI or HSI for reference to the new course.
- Press **-D>** to execute.
- Press **NAV** to abort without changing your flight path.

2.5 Mode Restore

To return the **NAV**, **WPT**, **FPL**, **CALC**, **AUX** or **NRST** key to the power-on default mode, press and hold the key for at least 1 second. No data is lost or affected by this action.



TRIMBLE 2101 Approach Plus

2.6 Entering a Flight Plan

This section explains step-by-step how to enter a flight plan. The flight for this example is from Austin, Texas (KAUS) to Ft. Worth, Texas (KFTW). The following are waypoints on this route:

AUS_A
AUS_V
GROWN_I
EDDEE_I
SARGE_I
MCDON_I
ACT_V
SLUGG1_{STAR}
FTW_A

The steps for entering this sample flight plan follow:

- Press **FPL** until the display says, STORED FLIGHT PLAN or NO STORED FLIGHT PLAN.
- Turn either the  or the  until the display says,



ADD NEW FLIGHT PLAN
start ++end

- Press **ENT**.

When **ENT** is pressed, the right plus symbol (+) on the bottom line becomes a flashing field ready for editing. Select the waypoint type (A, _APRCH, _SID, _STAR, V, N, I, or ualpha) here. In this sample flight plan, the first waypoint to be entered is an airport, AUS. So the flashing letter on the bottom line must be an "A".







Rotate  to select waypoint type.



ADD NEW FLIGHT PLAN
start +A -end

- If necessary, turn the  to change the flashing character to an “A”.

Follow the steps to enter the waypoint identifier, AUS.







- Turn the  to move the cursor to the next field so that you can select the airport identifier.
- Turn the  to display “A”.
- Turn the  to move the cursor to the next field.
- Use the  to select “U”.
- Turn the  to move the cursor to the next field.
- Turn the  to select “S”.

```
ADD NEW FLIGHT PLAN
start +A AUS -end
```

- Press  to complete the entry and add AUS to the flight plan.

```
EDIT FLIGHT PLAN
AUS A ++end
```

The next waypoint is the AUS VOR. Therefore, the flashing letter on the bottom line must be v.

- Press  to enter the next waypoint.
- Turn the  until the flashing character is a “V”.
- Turn the  to move cursor to the next field.
- Turn the  and  alternately to select characters “A”, “U”, and “S” for the AUS VOR.
- Press  to complete entry of the waypoint.

TRIMBLE 2101 Approach Plus

The intersections must be entered next.

- Press **ENT** to begin entry of the next waypoint, GROWN intersection.
- Turn the **⦿** to select waypoint type.



- Turn the **⦿** until the flashing letter is an "I" for intersection.
- Turn the **⦿** to move the cursor to the next field.
- Turn the **⦿** to select the letter "G" for the GROWN intersection.
- Alternate turning the **⦿** to move the cursor to the next field and the **⦿** to select the remaining letters in GROWN.
- Press **ENT** to complete this entry.

Repeat the steps for entering GROWN to add the remaining intersections (EDDEE, SARGE, and MCDON).

Add the ACT VOR.

- Press **ENT** to begin entry of the VOR.
- Turn the **⦿** to change the flashing waypoint type to a "V".
- Turn the **⦿** to move the cursor to the next field and the **⦿** to select the letters of the identifier, ACT.
- Press **ENT** to end this entry.

After ACT_v, add the destination airport, then the _STAR.

- Press **ENT** to begin entry of the destination airport.
- Turn the **⦿** to change the flashing waypoint type to an "A".
- Turn the **⦿** to move the cursor to the next field and the **⦿** to select the letters of the identifier, FTW.
- Press **ENT** to end this entry.
- Press **ENT** to begin entry of the STAR.

Rotate the **⦿** to select the procedure type.



```
EDIT FLIGHT PLAN
ACTv +_STAR -end
```





- Turn the **⦿** until flashing field is _STAR.
- Press **ENT**.

The Navigator chooses the first STAR associated with your destination, FTW. To select other STARS for FTW, use the **⦿**.



- Turn the **⦿** to select SLUGG1.
- Press **ENT**. (There is no prompt for this step. The **ENT** key will not be flashing.)

TRIMBLE 2101 Approach Plus

Select a transition.

- Turn the  to select the ACT transition.
- Press .
- Press  to add a STAR to the flight plan.
- Press  to complete the FPL editing process.
- Turn the  counterclockwise until LEG 1 is displayed in the lower left.

AUS _A	->FTW _A	176 _M
LEG 1:	AUS _A	↳AUS _V

- Press ,  to activate the flight plan. (The  key will not flash to prompt you.)

On the successful conclusion of these steps, the flight plan has been entered and activated.

Chapter 3

Approaches

The Trimble 2101 Approach Plus Navigator allows you to fly non-precision approaches to airports with published GPS-overlay and GPS-only approach procedures from data stored on the NavData® card. GPS overlay approaches, while identical to the underlying VOR or NDB procedure, provide greater accuracy and continuous course and distance information not available otherwise. GPS-only approaches, unlike VOR or NDB based approaches, can be designed such that the final approach course is aligned with runway heading.

TRIMBLE 2101 Approach Plus

3.1 What is a GPS Approach?

A GPS approach is a sequence of waypoints linked together just like a user-created flight plan, except that the TSO C-129 standards require that a GPS approach be extracted from the NavData® card as a single procedure. You may delete or replace this procedure, but you cannot edit this procedure.

Every GPS approach must have at least two waypoints; a Final Approach Fix (FF) and a Missed Approach point (MA). Most have a Missed Approach Holding (MH) point or other missed approach point.

Many approach waypoints are unnamed on the published Terminal Procedures. These include waypoints like DME positions, intersection of two radials, DME arc end points, etc. In addition, many overlay approaches need a Final Approach Fix to comply with TSO C-129(A1) requirements. Some Jeppesen approach charts depict these waypoint names; NOS charts do not. Until all the published charts depict the waypoint names, you must correlate the Jeppesen NavData information displayed on the Navigator with the published procedures to ensure proper interpretation of the waypoint identifiers.

The most common waypoint names are:

RWxx	Runway xx threshold missed approach waypoint.
MAxx	Runway xx missed approach waypoint.
Drrrd	DME arc waypoint defined by a radial and a distance from the arc reference VOR. In this convention, rrr is the FROM radial in degrees and d is a letter of the alphabet representing the distance in nautical miles. For example, A=1nm, J=10nm.
CFxx or CFxxx	Course fix waypoint for a runway xx or VOR radial xxx.
FFxx or FFxxx	Final approach fix for a runway, xx or radial, xxx.

NxxHP NDB approach runway xx intermediate holding pattern waypoint.

To aid in identifying approach waypoints, the Navigator displays subscripted letters after the identifier to indicate the waypoint type.

IF Initial Approach Fix.
I Intermediate Fix (Intersection available in WPT).
W Intermediate Fix (Terminal waypoint not available in WPT)
FF Final Approach Fix.
MA Missed Approach Point.
MH Missed approach Holding point.
DM DME arc reference waypoint.

The 2101 Plus accommodates procedure turns and holding pattern course reversals. These legs are depicted in the flight plan as:

PTURN_R

HOLD_L

The subscripted letters R and L indicate turn direction.

For software versions 240B and later, the subscripted letters L and R are not displayed with procedure turns.

3.2 The Basic Rules of GPS Approaches

There are two types of GPS approaches: overlay and GPS. Overlay approaches are based on existing procedures. GPS approaches are new approaches designed specifically for GPS. You fly both types exactly the same according to the following rules.

- The approach must be on the NavData® card and the card must be current.
- You may select the approach at any time prior to reaching the final approach fix.

TRIMBLE 2101 Approach Plus

- You may join the approach at any point or leg in the procedure except you may not join the FAF-MAP leg or select direct-to the MAP. Both are prohibited by the TSO. If you attempt to do either, the Navigator will offer the final approach course to the FAF instead.
- Enroute, the CDI is 5 nm full scale. Within 30 nm of the MAP, the CDI is 1 nm full scale. On the FAF-to-MAP leg, the CDI is 0.3nm full scale. You can view the CDI scaling at any time under the **MSG** key.
- Within a 30 nm radius of the airport, the Trimble 2101 Approach Plus prompts you for the barometric setting. Enter the barometric setting and press **ENT** to enable the approach. If you do not enable at this time, the unit prompts you again at 3 nm from the FAF. If you do not set it at this point, the GPS will not illuminate the approach annunciator at the FAF.
- The distance and bearing displayed on the Trimble 2101 Approach Plus is always relative to the current TO waypoint.
- If the green APR (approach) annunciator is not on at the FAF, execute the published missed approach procedure.
- If you are off course on the FAF to MAP leg, do not use the **D→**, **D→** key sequence to center the CDI. This will cancel the approach and begin the missed approach sequence.
- When flying the missed approach, fly all procedures and observe all altitude restrictions as published on the printed charts.

3.3 How to Select the Approach



There are two ways to select an approach with the Trimble 2101 Approach Plus. You can add an approach procedure to a flight plan or select one from **WPT**. When you add an approach

procedure to a flight plan, the Trimble 2101 Approach Plus places the procedure at the end of the flight plan, replacing the destination airport, if it was specified. If you select an approach procedure from WPT, the Trimble 2101 Approach Plus treats this procedure as any other flight plan, except that it prohibits editing of the procedure.





To insert an approach into the active flight plan:



- Press **FPL** to get to the active plan display.
Note: If you press and hold the **FPL** key for one second, the unit will display the active plan and active leg.
- Press **ENT** twice to open the flight plan for input.
Note: It does not matter where you insert the approach, the Trimble 2101 Approach Plus will place it at the end of the flight plan.
- If the approach modifies the active leg, you will be prompted to press **FPL** to cancel the flight plan and modify the active leg.
- Rotate **⦿** to **_APRCH** then press **ENT**. The Trimble 2101 Approach Plus presents the approaches for your destination airport. (Note: If the flight plan has no destination airport, the Navigator presents the approach for the last airport you viewed in WPT or NRST. In this case, press **ENT**, use the selector knobs to choose the desired airport identifier, then press **ENT** to complete the selection.)
- Rotate **⦿** to display the desired approach. Press **ENT** and rotate **⦿** to select the desired transition. Press **ENT** to complete the selection.
- Press **FPL** to insert the approach into the active flight plan.

TRIMBLE 2101 Approach Plus

- To select a different leg or reactivate the flight plan, rotate the  knob counter-clockwise until the desired leg is displayed.
- Press  twice to join that leg.

To activate an approach from the WPT mode:

- Press  repeatedly to get to the APPROACH mode.
- Press  then rotate  and  to select the desired approach and transition.
- Press  twice to activate the approach. Note: This cancels the active flight plan and provides guidance direct-to the first waypoint of the approach.

Once the approach is activated, the primary NAV page is displayed. To review the procedure, press  and use the  knob. Note: The first leg is -D-> IAF, indicating direct-to the initial approach fix.

3.4 How to Join an Active Approach in the Middle

When you are receiving radar vectors, it is common to join the approach at some intermediate leg or waypoint, or intercept the final approach course inbound.

To join an active approach leg:

- Press **FPL** to view the active flight plan.
- Use the **○** knob to view the desired leg (A to B).
- Press **→** once. If you want to join the leg, press **→** again. If you want to proceed direct-to either end of the leg, use the **○** knob to select the waypoint then press **→** again.

Note: You may join the approach at any point or leg in the procedure except you may not join the FAF-MAP leg or select direct-to the MAP. Both procedures are prohibited by TSO C-129.

To join the final approach course inbound or proceed direct-to the FAF.

- Press **WPT** to view the approach page. If the desired approach is not the one in the display, press **ENT** and use the **○** and **○** knobs to select it.
- For direct-to the FAF, rotate the **○** knob one click to the left.
- To intercept the final approach course inbound, rotate the **○** knob two clicks to the left.
- Press **→** twice.

3.5 How to Enable the Approach

Once you have selected an approach and are within 30 nm of the airport, the Navigator prompts you to input the barometric setting and enable the approach. If you did not enable the approach when prompted 30 nm from the airport, the Navigator will prompt you again 3 nm from the FAF. If you ignore this prompt, the

```
APPROACH ENABLE? ENT  
BARO: 30.12
```

Navigator will not illuminate the Approach light.

```
APPROACH ENABLED  
BARO: 30.12
```

Enter the baro setting then press **ENT** to enable the approach.

The Navigator uses the barometric setting to correct the pressure altitude received from the aircraft altitude encoder. The Navigator uses the altitude information when there are insufficient satellites available to do RAIM or 3D (4 satellite) navigation.

If your installation provides baro altitude to the Navigator, this screen will display the altitude in place of the baro setting, and the approach will enable automatically when you are within 30 nm of the airport.



3.5.1 View APPROACH ENABLE Status

Once you are within 30 nm of your destination airport, you may view the Approach Enable status by pressing the  key.

If you have already enabled the approach, the bottom line of the display alternates between displaying the baro setting and the name of the selected approach.





3.5.2 Update the Baro Setting

To update the baro setting after you have enabled the approach:

- Press  to view the APPROACH ENABLE status.
- Press .
- Use the selector knobs to change the baro setting.
- Press .

3.5.3 Disable the Approach

If, for any reason, you want to disable the approach after you have enabled it:

- Press  to view the APPROACH ENABLE status.
- Press .
- Use the  knob to select the ENABLED field.
- Use the  knob to select DISABLE.
- Press .

3.6 How to Perform a Course Reversal

The Navigator Plus supports three types of course reversals associated with non-precision approaches: procedure turn course reversals, holding pattern course reversals, and teardrop course reversals. For procedure turn course reversals, it provides a course outbound prior to the reversal and a course inbound once the reversal has been executed. For holding pattern course reversals, it provides a course inbound to the hold point.

TRIMBLE 2101 Approach Plus

3.6.1 Procedure Turn Course Reversals

The Navigator Plus provides guidance outbound to the procedure turn, prompts you with the outbound heading, then, once you have turned inbound, automatically track-changes to the inbound course. No operator intervention is required. No hold annunciator will illuminate.

Once you have passed the IAF, the Navigator Plus automatically provides an outbound course to the procedure turn. As you cross the p-turn point outbound, the GPS displays an advisory message to execute the procedure turn:

EXECUTE P-TURN
TURN TO XXX

where XXX is the procedure turn outbound heading. Press NAV to acknowledge this prompt. Fly the procedure turn manually, noting that the GPS CDI is providing guidance relative to the outbound course. As you turn to within 80 degrees of the inbound course and are at least 3nm out from the FAF, the GPS provides guidance inbound. Thereafter, the GPS provides guidance through the remainder of the approach.

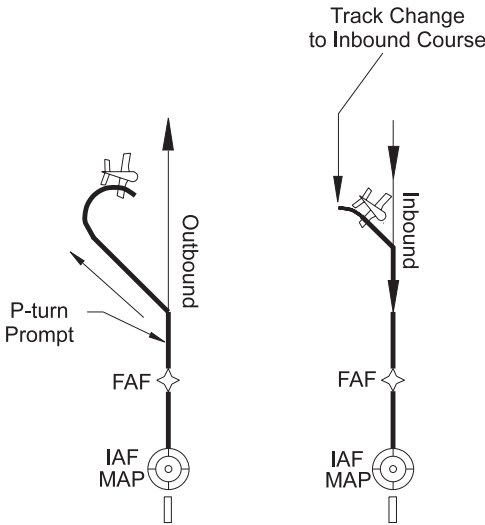

TN-PG 0002

3.6.2 Holding Pattern Course Reversals

The Navigator Plus provides guidance to the holding pattern hold point and then guidance along the holding course back to the holding fix. No operator intervention is required. No hold annunciator will illuminate.

As you pass over the holding fix the first time, the Navigator track-changes to show published course guidance inbound to the fix:

EXECUTE HOLD PATTERN
TO INBOUND CRS XXX°

where XXX° is the inbound course to the holding fix. Press  to acknowledge this prompt. Fly one turn through the pattern, using standard entry procedures. As you pass over the fix for the second time, the Navigator automatically sequences to the next waypoint in the approach. Thereafter, the GPS provides guidance through the remainder of the approach.

To remain in the holding pattern, follow the instruction found in section 5.11 Holding Patterns.

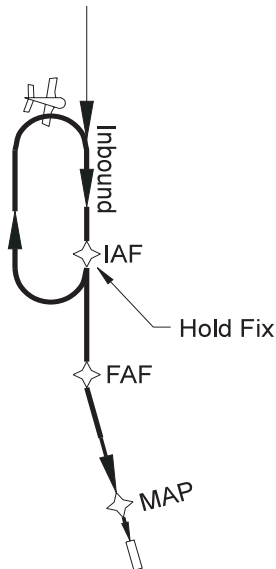

TRIMBLE 2101 Approach Plus

3.6.3 Teardrop Course Reversals

The Navigator Plus provides guidance outbound from the teardrop fix along the outbound leg. When the distance outbound from the fix is greater than the length of the inbound leg, the GPS provides a course inbound. Thereafter, the GPS provides guidance through the remainder of the approach.

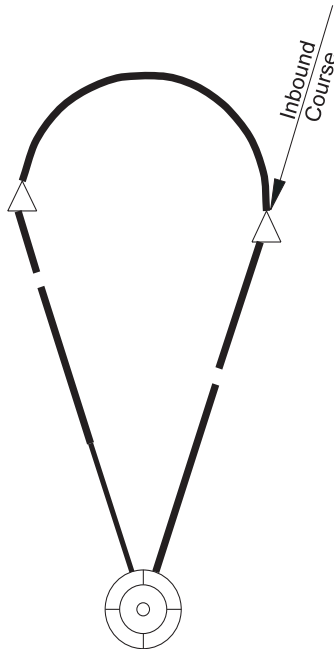

3.7 How to Fly a DME Arc Approach

Flying a DME Arc Approach is just like flying a flight plan. Simply keep the CDI centered while the Navigator provides precise guidance along the curved path of the DME Arc leg. You can fly direct to either Arc endpoint or choose to join the Arc along its length.

The Navigator does make distinctions between curved DME Arc legs and normal (straight) legs. While on the Arc leg, the Primary Nav page displays information relative to the DME arc and relative to the TO waypoint (the end point of the Arc).

VOR/DME or GPS RWY 11 into Crescent City, CA

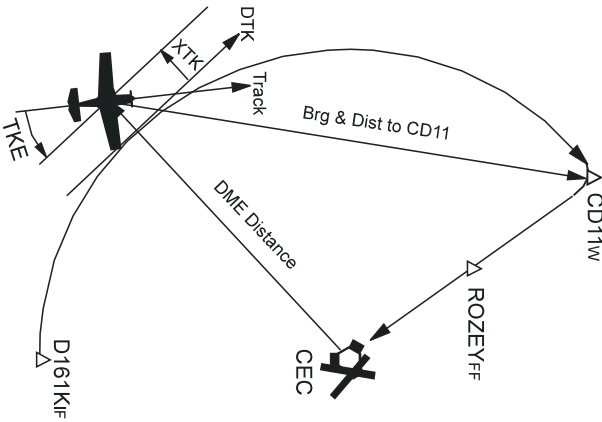
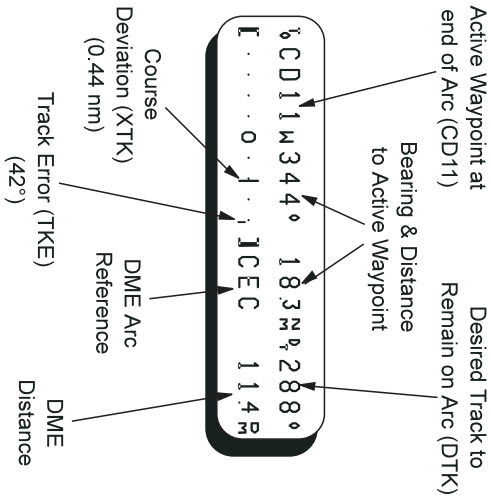

TRIMBLE 2101 Approach Plus

While on the Arc leg, the top line displays:

- Bearing and distance from present position to the end of the arc.
- Desired Track. This is a line tangential to the curved line of the arc, updated as you progress along the arc.

While on the Arc leg, the bottom line displays:

- Course Deviation (XTK) relative to the curved path of the arc.
- Identifier of the DME Arc reference station.
- Distance from the DME Arc reference station.

The waypoints of the approach in the example are named using the conventions described previously.

D161K_{IF} DME arc waypoint that is on the 161 degree radial from the reference station, at 11 DME (K is eleventh letter of the alphabet). Also the start of the arc.

CD11_w Course fix point for runway 11 at CEC. Also the end of the arc.

ROZEY_{FF} The final approach fix

MA11_{MA} The missed approach point for runway 11.

The other DME Arc distinction is in the approach waypoints. The Navigator data base contains the DME Arc reference point, indicated by the suffix DM. This point is placed between the arc end points to allow you to join the arc along its length.

The data base waypoints that comprise the CEC VOR/DME 11, D161K transition are:



D161K_{IF} - CEC_{DM} - CD11_w - ROZEY_{FF} -
MA11_{MA} - CEC_{MH}

To intercept the DME Arc leg, use the  key to join the D161K_{IF} to CEC_{DM} leg or the CEC_{DM} to CD11_w leg.

3.8 Missed Approach

Although normal procedure would dictate selection of a Missed Approach at the Missed Approach Point when the airport environment is not in sight, you may elect to select Missed Approach prior to reaching the MAP. Also, while on the FAF to MAP leg, the Navigator may recommend execution of a Missed Approach in the event of a RAIM loss or system failure.



3.8.1 Missed Approach Before the MAP

Once you are established on the final approach, the FAF to MAP leg, you may execute a missed approach at any time by pressing  .



When you execute the missed approach while on the FAF to MAP leg, the Navigator will:

- Change the CDI scale from 0.3 nm to 1 nm full scale.
- Turn on the Hold light indicating that it is not going to sequence at the MAP waypoint.
- Provide steering TO the MAP point, thence on an outbound track straight out FROM the MAP.

Upon reaching the MAP, execute the published climbout procedures.



To resume sequenced steering to the Missed Approach Holding Point, press  .

3.8.2 Missed Approach Beyond the MAP

As you pass the MAP, the Navigator provides steering straight out FROM the MAP and illuminates the  key as a prompt. Waypoint sequencing is suspended at the MAP to allow you to comply with all published missed approach procedures before proceeding to the Missed Approach Holding Point. To resume waypoint sequencing to the Missed Approach Holding Point, press  .



TRIMBLE 2101 Approach Plus





To execute a missed approach after passing the MAP:

- Comply with the published missed approach procedures.
- Press   to resume waypoint sequencing to the Missed Approach Holding Point

3.9 How to Fly a GPS Approach





Non-precision approaches flown with the Trimble 2101 Approach Plus all follow these same basic series of events.

- Select the desired approach from the WPT mode or add the approach procedure to the active flight plan.
- Enable the approach by entering the baro setting when prompted by the Navigator. This prompt happens automatically when you are 30 nm from your destination. (The Navigator will prompt you again near the FAF if you ignore the initial prompt.)
- Use the  key and the  and  knobs to select the procedure entry point. You may intercept any leg up to the FAF - MAP leg or select direct-to any waypoint up to the FAF.
- If the procedure is a DME arc or straight-in, your work is done. Keep the CDI centered while the Trimble 2101 Approach Plus guides you to the MAP.
- If the procedure requires a course reversal, the Navigator provides an outbound course prior to flying the course reversal. As you turn inbound on the course reversal, the Navigator automatically changes track to the inbound course.
- Establish yourself on the final course inbound.
- Ensure the approach light is ON as you cross the FAF inbound. If the light is not on, execute a missed approach after passing the MAP.
- If the approach light is ON, fly to the MAP, following the published vertical profile.

- To execute a missed approach prior to crossing the MAP, press  . Remember, always fly to the MAP, even if you went missed approach at the FAF.
- After you have crossed the MAP and complied with all published missed approach procedures, press 
 to resume waypoint sequencing to the missed approach holding fix.

WARNING!

A direct course from the MAP to the holding point may violate the published missed approach procedure. Always fly all missed approach procedures.

- Once you have instructed the Navigator to execute the missed approach at or beyond the MAP by pressing  , the Navigator provides course guidance direct to the waypoint following the MAP and waypoint sequencing is active.
- When the TO waypoint is the missed approach holding point (mh), the Navigator automatically illuminates the HOLD annunciator to remind you that this is the holding fix.
- At waypoint passage, the TO/FROM flag on the CDI indicates FROM and the Navigator provides guidance outbound FROM the waypoint.
- To fly the holding pattern, press , enter the published holding course TO the waypoint using the  knob. Press . Fly the holding pattern like a VOR/DME hold. (See Section 5-11 for instructions on holding at any waypoints other than the missed approach holding point.)

TRIMBLE 2101 Approach Plus

3.10 RAIM

RAIM, Receiver Autonomous Integrity Monitor, is a method employed by the computers in the Navigator to monitor the integrity of the navigation information received from the satellites. RAIM estimates an upper limit on the position accuracy available under the conditions dictated by the satellites. The limit is completely dependant upon the number of satellites in view and their relative positions in the sky (their geometry). TSO C-129 specifies three RAIM limits: En route, Terminal and Approach.

The Navigator applies the more stringent Terminal limit to both the en route and terminal flight phases. It applies the Approach limit to the approach phase.

The satellites transmit information, called almanac data, about their orbital positions and health. The Navigator uses the almanac data to predict the available satellite coverage and therefore the RAIM limit, for any location at any time in the future. The Navigator limits the prediction time to 24 hours.

TSO C-129 contains strict requirements governing the use and availability of RAIM as it pertains to the approach flight phase:



- RAIM predictions must indicate that approach RAIM will be available for the duration of the FAF to MAP leg.
- Approach RAIM must be in use at the FAF.
- Approach RAIM cannot be unavailable for more than five minutes while between the FAF and MAP.

3.10.1 RAIM Prediction



In order to fly a non-precision approach, the Navigator must have sufficient satellite coverage at the destination airport to provide approach RAIM. The Navigator uses almanac information to provide RAIM limit predictions for a destination and time (within the next 24 hours). These predictions are for plus and minus fifteen minutes of the ETA. You may edit the ETA field to determine the RAIM availability at other times. You may edit the airport identifier to determine RAIM availability at any airport in the data base.

If your Active Flight Plan ends with an airport or approach, the RAIM prediction uses that airport for the prediction. If your Active Flight Plan does not end in an airport or approach, or you have no Active Flight Plan, the prediction uses the airport last viewed under the  key. The Navigator uses the ETA as determined by present ground speed and wind, if available.



Use the Approach RAIM page found under Sensor Status Mode of the Auxiliary key to determine the RAIM limit availability at a destination and time.

- Press  repeatedly to get to the SENSOR STATUS mode.
- Rotate the  knob clockwise to access the APR RAIM AVAILABLE page.

To change the ETA:

- Press .
- Use the selector knobs to change the ETA.
- Press .

To change the airport identifier:

- Press .
- Use the  knob to place the cursor in the identifier field.
- Use the selector knobs to change the airport identifier.
- Press .

TRIMBLE 2101 Approach Plus

When approach RAIM is available at the selected destination and time:

```
APR RAIM AVAILABLE:  
EUGa 21:57L ±15 MIN
```

When approach RAIM is not available at the selected destination and time:

```
RAIM NOT AVAILABLE  
PDX 14:57L
```

In the event navigation is not available due to satellite coverage:

```
NAV NOT AVAILABLE  
PDX 14:57L
```

3.10.2 RAIM Prediction on the Approach

At two miles from the FAF, the Navigator predicts the RAIM limit available for the remainder of the approach, to the MAP, at present ground speed. If Approach RAIM is predicted, the Navigator illuminates the approach light. If not, the Navigator displays the message:

```
RAIM PREDICTED N/A  
EXE MISSED APR(DIR)
```

At the FAF, the Navigator ensures that Approach RAIM is in use. If so, the Navigator continues with the approach. Otherwise, the Navigator displays the message:

```
APPROACH RAIM LOST  
EXE MISSED APR(DIR)
```

If RAIM availability is lost for five minutes while on the FAF to MAP leg, the Navigator displays the message:

```
APPROACH RAIM LOST  
EXE MISSED APR(DIR)
```

If the Navigator detects a failed satellite, it displays the message:

```
RAIM ERROR  
POSITION FIX INVALID
```



```
RAIM ERROR  
EXE MISSED APR(DIR)
```

TRIMBLE 2101 Approach Plus

This page intentionally left blank.

Chapter 4

The Waypoint Key

The  key features eight modes:

- Airport
- Approach
- SID
- STAR
- VOR
- NDB
- Intersection
- User

Each press of the  key selects the next mode. Press and hold the key for one second to return to the Airport mode. Within each mode, you will find information unique to the waypoint or procedure category.

4.1 Waypoint Information

The Navigator uses the Jeppesen NavData Database Card to provide direct access to worldwide data on waypoints and procedures. The waypoint categories are: Airports, VORs, NDBs, and Intersections. The procedure categories are: Approaches, SIDs and STARs. Both the North American and International database cards are required for complete worldwide information. The following describes the database information available from the Waypoint mode. The small letter after a waypoint identifier denotes the waypoint category.

Airports (A) or (M)

Identifier, city name, airport name, communications frequencies, field elevation, runway information, lighting, approach information, services, and latitude/longitude. The (M) denotes a military operation.

Approaches

Airport Identifier associated with Approach, Approach Name (with Runway, when applicable), IAFs and Transitions, DME Arcs, Approach Waypoints with Type Identifiers (IAF, FAF, MAP, MAHP, Intermediate Waypoints).

Standard Instrument Departures

Airport Identifier associated with SID, SID Name, Applicable Runways, SID Transitions, and SID Waypoints.

Standard Terminal Arrival Routes

Airport Identifier associated with STAR, STAR Name, STAR Transitions, and STAR Waypoints.

VORs (V)

Identifier, city name, VOR name, navigation frequency, Morse code for identifier, and latitude/longitude.

NDBs (N)

Identifier, city name, NDB name, navigation frequency, Morse code for identifier, and latitude/longitude.

Intersections (I)

Identifier, region name, and latitude/longitude.

User Waypoint (U)

User identifier and latitude/longitude.

All Categories

Bearing to waypoint.

Distance to waypoint.

Radial from waypoint (Press and hold  for From radial).

4.2 The Waypoint Displays

The Navigator contains information about each waypoint in the data base. The available information varies depending on the waypoint category.

To access these displays:

- Press **WPT** to display the Airport mode.
- Rotate the  knob clockwise to view the different displays.

Some typical displays are shown below.

Airport

↵ IAH A 086° 1400M C1sB HOUSTON TX	↵ IAH A 086° 1400M C1sB HOUSTONINTERCONTINE
↵ IAH A 086° 1400M C1sB ATS 124.05APP 120.05	↵ IAH A 086° 1400M C1sB TWR 125.35GND 121.7
↵ IAH A 086° 1400M C1sB CTF ----- UNI 122.95	↵ IAH A 086° 1400M C1sB ELEVATION 98'
↵ IAH A 086° 1400M C1sB BEACON, LIGHTING,	↵ IAH A 086° 1400M C1sB IFR APCH, SERVICES
↵ IAH A 086° 1400M C1sB 14L 12000x150', HARD	↵ IAH A 086° 1400M C1sB , LEFT TRAFFIC
↵ IAH A 086° 1400M C1sB 429° 58.829N 95° 20.382W	

Approach

Turn the  knob right to display these pages:

IAH_A <VOR/DME14L>APR
IAF/TRAN: CONHO_F

IAH_A <VOR/DME14L>APR
LEG01: CONHO_F CF14L_W

IAH_A <VOR/DME14L>APR
LEG02: CF14L_W KINKS_F

IAH_A <VOR/DME14L>APR
LEG03: KINKS_F MA14L_W

IAH_A <VOR/DME14L>APR
LEG04: MA14L_W COSBI_I

Turn the  knob left to display these pages:

IAH_A <VOR/DME14L>APR
APR CRS 154°_WKINKS_F

IAH_A <VOR/DME14L>APR
DIR TO FAF: KINKS_F

SID

ADS_A <DALL9 >SID
RWY:ALL TRAN:EIC_V

Turn the  knob right to display these pages:

ADS_A <DALL9 >SID
LEG01: DFW_V BOXOR_I

ADS_A <DALL9 >SID
LEG02: BOXOR_I RESLR_I

ADS_A <DALL9 >SID
LEG03 RESLR_I EIC_V

TRIMBLE 2101 Approach Plus

STAR

Turn the  to the right to view these pages.

ADSA <AQN4 >STR TRAN:ABIv RWY:15	ADSA <AQN4 >STR LEG01: ABIv COTTNI
ADSA <AQN4 >STR LEG02: COTTNI CURVINI	ADSA <AQN4 >STR LEG03: CURVINI AQNV
ADSA <AQN4 >STR LEG04: AQNV MARKMI	ADSA <AQN4 >STR LEG05: MARKMI BRYARI
ADSA <AQN4 >STR LEG06: BRYARI HULENI	ADSA <AQN4 >STR LEG07: HULENI FLATOI
ADSA <AQN4 >STR LEG08: FLATOI CREEKI	

VOR

Turn the  to the right to view these pages.

VAUSV 087°1281M AUSTIN TX	VAUSV 087°1281M AUSTIN
VAUSV 087°1281M VOR FREQUENCY 117.1	VAUSV 087°1281M CODE: - - - - -
VAUSV 087°1281M 430°17853N 97°42.198W	

NDB

```

%AUN 113° 693M
AUSTIN TX
  
```

Turn the  knob right to display these pages:

```

%AUN 113° 693M
AUSTI
  
```

```

%AUN 113° 693M
NDB FREQUENCY 353.0
  
```

```

%AUN 113° 693M
CODE: - - - -
  
```

```

%AUN 113° 693M
430° 14.140N 97° 37.543W
  
```

Intersection

```

%EDDEEI 110° 675M
REGION: SOUTH CENTRAL
  
```

Turn the  knob right to display this page:

```

%EDDEEI 110° 675M
430° 46.862N 97° 33.057W
  
```

User

```

%TRMBLU 270° 000M
437° 23.577N 122° 02.270W
  
```

4.3 Selecting Airport, VOR, NDB, Intersection or User Waypoints

There are four methods for selecting Airport, VOR, and NDB waypoints:

- Enter the waypoint identifier.
- Enter the waypoint city name.
- Enter the waypoint name.
- Scan the identifiers in the database.

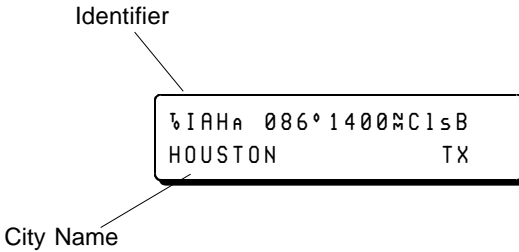

There are two methods for selecting Intersection and User waypoints:





- Enter the waypoint identifier.
- Scan the identifiers in the database.

Once you have selected the desired identifier, you may view additional waypoint information in the bottom line of the display.

- Rotate the  knob to view additional waypoint information on the bottom line of the screen.







4.3.1 Select a Waypoint by Identifier

Use this method to select a waypoint by Identifier. This is by far the most commonly used method.

- Press  until the desired category is selected.
- Press .
- Rotate the  knob, in either direction, until the desired letter is displayed.
- Rotate the  knob clockwise to select the next character field.
- Repeat the previous two steps until the desired waypoint identifier is displayed.
- Press  to complete the selection.

4.3.2 Select a Waypoint by City Name







Use this method to select a waypoint by City Name. There are many duplicate City Names in the data base. To select between duplicate city names, position the cursor under the last letter of the City Name, then use the  knob to move among the duplicates.

- Press  until the desired category is selected.
- Press .
- Use the  knob to position the cursor in the City Name field.
- Rotate the  knob, in either direction, until the desired letter is displayed.
- Rotate the  knob clockwise to select the next character field.
- Repeat the previous two steps until the desired City Name is displayed.
- Press  to complete the selection.

TRIMBLE 2101 Approach Plus



4.3.3 *Select a Waypoint by Waypoint Name*

Use this method to select a waypoint by Waypoint Name.

- Press  until the desired category is selected.
- Turn the  knob one click to the right to view the Waypoint Name field.
- Press  .
- Use the  knob to position the cursor in the Waypoint Name field.
- Rotate the  knob, in either direction, until the desired letter is displayed.
- Rotate the  knob clockwise to select the next character field.
- Repeat the previous two steps until the desired City Name is displayed.
- Press  to complete the selection.

4.3.4 *Scan Waypoint Identifiers*

Use this method to select a waypoint scanning through the entire data base.

- Press  until the desired category is selected.
- Use the  knob to select a Waypoint Identifier.

Once you have selected the desired identifier, you may view additional waypoint information in the bottom line of the display.

- Rotate the  knob to view additional waypoint information on the bottom line of the screen.

4.4 Selecting Approach, SID, and STAR Procedures

Approach, SID, and STAR procedures differ from waypoints in that the procedures are lists of waypoints linked together as a subroute, selected by airport identifier. Some airports have multiple procedures with multiple transitions that depend on your direction of flight and runway in use. Once you have completed the selection and activated the procedure, the Navigator retrieves the entire procedure from the NavData card.

The Approach, SID, and STAR Procedure modes include several pages for each procedure. These pages are controlled by the  knob and appear in the display's bottom line.

Once activated, you may edit SID and STAR procedures. You may not edit Approach procedures.

Approach procedures are defined with up to three parameters:

- Airport identifier
- Approach name
- Transition name

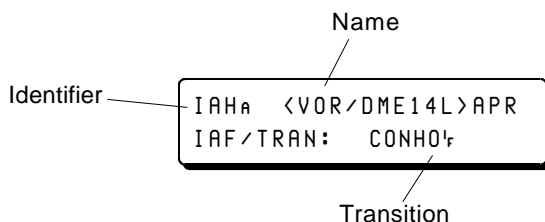

TRIMBLE 2101 Approach Plus

SID and STAR procedures are defined with up to four parameters:

- Airport identifier
- SID or STAR name
- Transition name

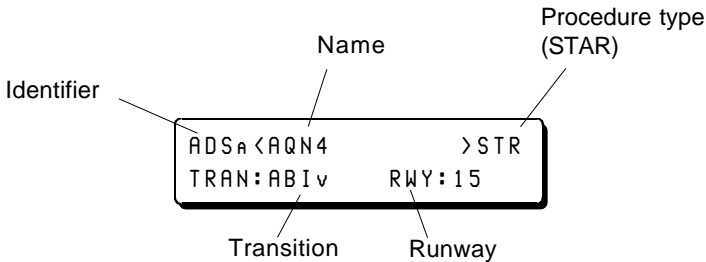
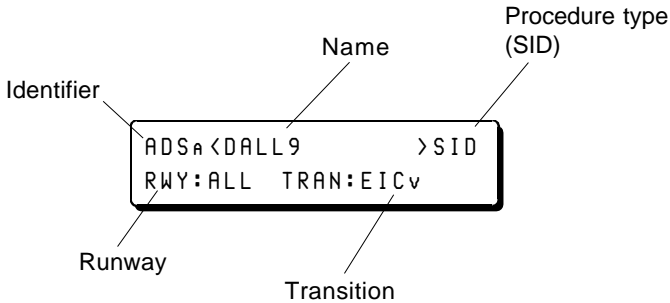







- Runway

Some SIDs do not have an associated transition. In this case, the transition field is blank.

The Approach, SID and STAR categories default to the procedures available for the airport that is currently displayed in the Airport category.

4.4.1 To Fully Define a Procedure

- Press  until the desired procedure category is selected (Approach, SID, STAR).
- Press  .
- Rotate the  knob counterclockwise until the flashing cursor is placed in the Airport field.
- Edit the Airport identifier with the rotary selector knobs.
- Rotate the  knob until the flashing cursor is placed in the procedure name field.
- Edit the name field with the rotary selector knobs.
Note that the Navigator only display available procedure names as you rotate the selector knob.
- Rotate the  knob clockwise until the flashing cursor is placed in the procedure transition field.
- Edit the transition field with the rotary selector knobs.
Note that Navigator displays only available transitions as you rotate the selector knob.
- For a SID or STAR, rotate the  knob until the flashing cursor is placed in the runway field.
- Edit the runway field with the rotary selector knobs.
Note that Navigator displays only available runways as you rotate the selector knob.
- Press  to complete the procedure selection.

4.4.2 To Select a Procedure Name



To change just the procedure name for a selected airport and procedure:

- Rotate the  knob to select another procedure name.
(If the airport has only one named procedure, the Navigator ignores the knob rotation.)

TRIMBLE 2101 Approach Plus

4.4.3 To Select a Transition

To change just the transition for a selected airport and procedure:



- Press  .
- Rotate the  knob to select another IAF/Transition.
- Press  to complete the IAF/TRAN selection. (If the airport has only one transition, the Navigator ignores the knob rotation.)

4.5 Activating a Waypoint or Procedure from WPT

Although waypoints and IFR procedures may be linked together in a Flight Plan, it is often more convenient to activate them autonomously, especially when a clearance change requires immediate selection of a waypoint or procedure not included in the stored plan.

4.5.1 Selecting Direct Steering to Waypoint in WPT

Any waypoint, in any Waypoint mode category, may be selected as the Active Waypoint. After the second press of the direct-to key, the Navigator automatically switches to the NAV mode.

- Select a waypoint (Airport, VOR, NDB, Intersection, User).
- Press  once.
- Use the  knob to change the course to/from the waypoint, if desired.
- Press  a second time to make the waypoint the Active Waypoint.



4.5.2 Activating a SID or STAR Procedure

Any SID or STAR Procedure listed in the Jeppesen NavData Database may be activated from the WPT mode using the  key. The Navigator has three options for activating SID and STAR Procedures:

- Fly direct to the first waypoint.
- Join any leg of the procedure.
- Fly direct to any waypoint.



4.5.2.1 Select Direct to the First Waypoint

Use this option to fly the entire procedure.

- Select a SID or a STAR.
- Press  once.
- Use the  knob to change the course to/from the waypoint, if desired.
- Press  to make the first waypoint the Active Waypoint and activate the procedure.

4.5.2.2 Join a Leg of the Procedure





Use this option to join any leg of the procedure.

- Select a SID or a STAR.
- Use the  knob to select the desired leg.
- Press  once and note the leg's course.
- Press  a second time to join the leg and activate the procedure.

TRIMBLE 2101 Approach Plus

4.5.2.3 *Direct-to Any Waypoint in the Procedure*

Use this option to fly direct to any waypoint of the procedure.

- Select a SID or a STAR.
- Use the  knob to select the leg with the desired waypoint.
- Press  once.
- Use the  knob to select the desired waypoint; left to select the first waypoint of the leg, right to select the second.
- Note the course to the waypoint. Use the  knob to change the course, if desired.
- Press  a second time to fly direct to the waypoint and activate the procedure.

4.6 User Waypoints

You may store up to 250 User Waypoints in the Navigator's internal data base. Once stored, you may edit or erase User Waypoints. A User Waypoint may have any alphanumeric name from one to five characters long.

4.6.1 Creating a User Waypoint

The Navigator features three methods for defining User Waypoints.







- Present Position
- Latitude and Longitude
- Bearing and Distance from another waypoint

To create a user waypoint from aircraft present position:









- Press **WPT** to get to the USER mode.
- Rotate the  knob right or left to get to ADD WAYPOINT?(ENT)
- Press **ENT**.
- Use the selector knobs to name the waypoint
- Press **ENT**. Display is now SAVE USING THIS POSITION?(ENT)
- Press **ENT** to store waypoint as present position.

TRIMBLE 2101 Approach Plus

To create a user waypoint defined by a latitude and longitude:

- Press  to get to the USER mode.
- Rotate the  knob right or left to get to ADD WAY-POINT? (ENT).
- Press .
- Use the selector knobs to name the waypoint.
- Press . Display is now SAVE USING THIS POSITION? (ENT).
- Rotate the  knob right to get to SAVE USING LAT/LON? (ENT).
- Press .
- Use the selector knobs to enter the latitude and longitude.
- Press  to store the waypoint.

To create a user waypoint as a range and bearing from another waypoint:





- Press  to get to the USER mode.
- Rotate the  knob right or left to get to ADD WAY-POINT? (ENT).
- Press .
- Use the selector knobs to name the waypoint.
- Press . Display is now SAVE USING THIS POSITION? (ENT).
- Rotate the  knob right to get to WPT+RNG&BRG? (ENT).
- Press .
- Use the  key,  key and selector knobs to choose the base waypoint.
- After you have selected the base waypoint, press .

- Use the selector knobs to enter the bearing and distance FROM the base waypoint.
- Press  to store the waypoint.

4.6.2 Editing a User Waypoint

You may edit the name or position of any stored user waypoint.





To edit a user waypoint:

- Press  to get to the USER mode.
- Use the  knob to view the desired waypoint.
- Rotate the  knob right or left to get to EDIT ? (ENT).
- Press .
- Use the selector knobs to edit the waypoint name, latitude and longitude as desired.
- Press  to save the changes.

4.6.3 Erasing a User Waypoint

You may erase any stored user waypoint.

To erase a user waypoint:

- Press  to get to the USER mode.
- Use the  knob to view the desired waypoint.
- Rotate the  knob right or left to get to ERASE ? (ENT).
- Press .
- Press  to confirm the erasure. (Press any other key to abort the erasure and retain the waypoint.)



4.7 Activating an Approach Procedure

Any Approach Procedure listed in the Jeppesen NavData Database may be activated from the WPT mode using the  key. The Navigator has several options for activating Approach Procedures:

- Fly direct to the first waypoint.
- Join any leg of the procedure except the FAF to MAP leg.
- Fly direct to any waypoint up to the FAF.
- Direct to the FAF.
- Intercept final approach course inbound.



4.7.1 *Select Direct-to the First Approach Waypoint*

Use this option to fly the entire procedure.

- Select the Approach.
- Press  once.
- Use the  knob to change the course to/from the waypoint, if desired.
- Press  to make the first waypoint the Active Waypoint and activate the procedure.





4.7.2 *Join a Leg of the Approach Procedure*

Use this option to join any leg of the procedure up to the FAF to MAP leg.

- Select an Approach.
- Rotate the  knob clockwise to select the desired leg.
- Press  once and note the leg's course.
- Press  a second time to join the leg and activate the procedure.





4.7.3 *Direct to Any Waypoint in the Approach Procedure*

Use this option to fly direct to any waypoint of the procedure.

- Select an Approach.
- Use the  knob to select the leg with the desired waypoint.
- Press  once.
- Use the  knob to select the desired waypoint; left to select the first waypoint of the leg, right to select the second.
- Note the course to the waypoint. Use the  knob to change the course, if desired.
- Press  a second time to fly direct to the waypoint and activate the procedure.

4.7.4 *Fly Direct to the FAF*



Use this option to fly direct to the Final Approach Fix.

- Select the Approach.
- Rotate the  knob one click counterclockwise.
- Press  once.
- Note the course to the waypoint. Use the  knob to change the course, if desired.
- Press  a second time to fly direct to the FAF and activate the procedure.

TRIMBLE 2101 Approach Plus

4.7.5 *Intercept the Final Course Inbound*

Use this option to intercept the published final approach inbound to the FAF.

- Select the Approach.
- Rotate the  knob two clicks counterclockwise.
- Press  once.
- Note the course.
- Press  a second time to join the course inbound to the FAF and activate the procedure.

Chapter 5

The Flight Plan Key

The Flight Plan Key features four modes:

- Active Plan
- Active Plan Legs
- Stored Flight Plans
- Stored Flight Plans Legs.

The first press of the key takes you to Active Plan mode, the second to Active Plan Legs. The third press takes you to Stored Flight Plans, the fourth to Stored Flight Plans Legs. Each additional press switches between Stored Flight Plans and Stored Flight Plans Legs. To return to Active Plan mode, press and hold the  key for one second.

Use the  key to select a stored flight plan for activation, view, edit, or cancel the active flight plan, and to create, edit, review, reverse or erase stored flight plans.

The Navigator lets you store up to 400 waypoints in up to 40 flight plans. The maximum number of waypoints in any one plan is 40. A typical flight plan would follow this format:

- Departure airport
- SID procedure
- En route waypoints (VORs and Intersections)
- STAR
- Approach for destination airport

TRIMBLE 2101 Approach Plus

5.1 Flight Plan Modes

The four FPL modes contain several data pages each.

FPL

(first
press)

Active Plan or “NO ACTIVE FLIGHT PLAN”.

Displays the departure and destination waypoints and waypoint identifiers of current leg. Use either selector knob to change legs. Legs are denoted as NOW, NEXT, or LAST.

```
LAXA ->PHXA ACTIVE  
NOW: PDZv ↳PSPA
```

Press **ENT** to edit. Press **-D-** twice to fly the displayed leg.

FPL



(second
press)

Active flight plan legs page (if an Active flight plan exists) displays a leg waypoint pair along with bearing, distance and ETE for the leg. Legs are denoted as NOW, NEXT 1, or LAST 1. Use either selector knob to change legs.

```
NEXT 2:PDZv ↳PSPA  
082° 51.3M ETE 0:26
```

FPL

(third
press)

Stored flight plans or “NO STORED FLIGHT PLANS” message. Use the  knob to view other stored flight plans. Displays the departure and destination waypoints and waypoint identifiers of the first leg of a stored flight plan. Use the  knob to change legs. Legs are denoted as LEG 1, LEG 2...

```
LAXA ->PHXA 325M  
LEG1: LAXA ↳PDZv
```

Press the **ENT** key to edit. To activate the flight plan, press **-D->** on the desired leg, choose direct-to or join, then press **-D->** a second time.

To add additional flight plans, rotate the **⦿** knob past the first or last stored flight plan to get the “ADD NEW FLIGHT PLAN” display. Build another flight plan or use the **⦿** knob to move back to the stored flight plans.

ADD NEW FLIGHT PLAN
start ++end

FPL
(fourth
press)

Stored flight plan legs page. Use either selector knob to change legs. Displays a leg waypoint pair along with bearing, distance, and ETE for the leg. Legs are denoted as LEG 1, LEG 2...

LEG2:PDZv ↳PSP_A
082° 513_M ETE 0:26

To activate the flight plan, press **-D->** on the desired leg, choose direct to or join, then press **-D->** a second time.

Press and Hold the **FPL** key at any time to return to the active leg of the active flight plan.

The **FPL** key flashes when the Navigator is displaying the Active Legs or Stored Legs pages.

5.2 Entering Waypoints and Procedures

When editing or creating a flight plan, you have the choice of entering waypoints, by identifier, directly with the **ENT** key and selector knobs, or selecting waypoints from one of the **WPT** or Nearest modes by identifier, name, or city name. Use the direct entry method when you know the identifier. Use the WPT or Nearest method when you do not know the identifier.

You can enter SID, STAR, and Approach procedures into any flight plan from the Active Plan or Stored Flight Plans mode. It is best if you build the flight plans starting with the departure airport and ending with the destination airport. The Navigator can then present the SID for the departure airport and the STAR and Approach for the destination airport.

The Navigator will accept only one SID, one STAR, and one Approach in a flight plan.

When entering waypoints and procedures, you first select the waypoint or procedure type then the waypoint identifier. The waypoint types are:

A	Airport waypoint type
_APRCH	Approach procedure type
_SID	SID procedure type
_STAR	STAR procedure type
V	VOR waypoint type
N	NDB waypoint type
I	Intersection waypoint type
U	User waypoint type

When entering waypoints, select the waypoint type, select the identifier, then press **ENT** to insert the waypoint into the flight plan.

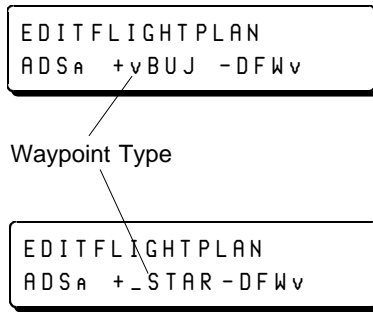

When entering procedures, select the procedure type, select the complete procedure (airport, name, transition and runway), then press **FPL** to insert the procedure into the flight plan.





When you add an Approach procedure to a flight plan, the Navigator replaces the destination airport with the procedure and closes the editing session. If you later delete the Approach procedure, the Navigator reinserts the related airport as the last waypoint of the plan.

As long as you do not edit waypoints of a SID or STAR procedure, the Navigator will treat the procedure as a single entry. If you delete or replace the unedited procedure, the Navigator deletes or replaces the entire procedure. If you edit the procedure, the Navigator converts it into a series of separate waypoints. To remove the edited procedure, you must delete each waypoint of the procedure.

5.3 Building a Flight Plan



Flight plans are created from the Stored Flight Plans mode. You may enter the waypoint identifier directly or select a waypoint from WPT or Nearest. You may enter SID, STAR, and Approach procedures now, or use Active Flight Plan edit to add them later.

To build a new flight plan:

- Press  to get to “STORED FLIGHT PLANS”.
- Rotate either knob left or right until “ADD NEW FLIGHT PLAN” is displayed.
- Note the flashing ++ symbols between “start” and “end”. These symbols indicate the waypoint insertion point. When a flight plan has more than two waypoints, use the  knob move the insertion point.
- Press the flashing  to add the first waypoint.
- Add waypoints and procedures as described in the following paragraphs.
- To exit Flight Plan Create, press  when ++ is displayed.





5.3.1 Adding a Waypoint by Identifier

If you know the waypoint identifier:

- You must have the flashing ++ symbols displayed.
- Press  to get a flashing category letter.
- Use the  knob to select a waypoint category.
- Use the selector knobs to enter the identifier.
- Press  to add the waypoint.





5.3.2 Adding a Waypoint Using WPT

If you do not know the waypoint identifier, use  to select the waypoint by name or city name.

- You must have the flashing ++ symbols displayed.
- Press .
- You can change the category by pressing the  key until the desired category is selected.
- Use the  key and selector knobs to select the waypoint by name or city name.
- Press the flashing  key to enter the selection into the flight plan.

5.3.3 Adding a Waypoint Using NRST



To add a waypoint to a flight plan from the list of nearest waypoints:

- You must have the flashing ++ symbols displayed.
- Press .
- You can change the category by pressing  until the desired category is selected.
- Use the  knob to choose a waypoint from the list of 20.
- Press  to enter the selection into the flight plan.



TRIMBLE 2101 Approach Plus

5.3.4 Adding a Procedure

To add a procedure to the flight plan:

- You must have the flashing ++ symbols displayed.
- Press  to get a flashing category letter.
- Use the  knob to select a procedure category.
- Press .

You can change the procedure category by pressing  until the desired category is selected.

- Use the  key and selector knobs to select the procedure.
- Press  to enter the procedure into the flight plan.

5.4 Editing a Flight Plan

In the edit mode, you can add, replace, or delete waypoints and procedures from the selected flight plan. You can edit the active flight plan or a stored flight plan at any time. The steps are the same, except for some special considerations given to the waypoints of the Active Leg.

You cannot edit a Flight Plan from the legs page, denoted by a flashing  key.



Approach procedures can only be replaced or deleted. You cannot edit Approach procedures.

SID and STAR procedures can be replaced, deleted, or edited. When you edit a SID or STAR procedure in a flight plan, the Navigator breaks that procedure into individual waypoints. You can no longer replace or delete an edited procedure. But since the procedure is now broken into separate waypoints, you can replace or delete any of the individual waypoints.

If you attempt to edit the waypoints of the Active Leg, the Navigator displays the message:



(FPL) TO CANCEL AND
MODIFY ACTIVE LEG

If you confirm the edit request by pressing , the Navigator cancels the current flight plan, leaving the current leg guidance (guidance between From and To waypoints) intact. Complete the edit then reactivate the flight plan with the  key.

To edit a stored flight plan, you begin by pressing .

TRIMBLE 2101 Approach Plus

5.4.1 Insert, Replace or Delete Waypoints

This paragraph describes how to edit waypoints in the flight plan. For information on editing SID, STAR, and Approach procedures, see the following paragraphs.

To add, delete, or replace a waypoint in a flight plan:

- Use the **FPL** key and selector knobs to get to the desired flight plan.
- Press **ENT** to get the flashing ++ symbols.
- Use the **○** knob to select the edit point in the flight plan.

To insert a waypoint:

- Press **ENT**.
- Use the **○** knob to select a waypoint category.
- Use the selector knobs to select a waypoint.
- Press **ENT** to add the waypoint to the flight plan.

To replace or delete the waypoint to the right of the ++:

- Use the **○** knob to select REPLACE, or DELETE.
- Press **ENT**.
- Repeat the insert and replace/delete steps as necessary.
- Press **FPL** to quit the editing session.

5.4.2 Insert a Procedure

Usually, you will want to insert procedures that are associated with your planned departure and destination airports. If, however, you choose procedures that are not associated with these airports, the Navigator uses several rules to ensure that the selected SID, STAR, and Approach procedures are placed into the flight plan correctly.

When you insert a SID, the Navigator places it at the beginning of the flight plan, replacing the departure airport.

When you insert a STAR, the navigator places it just before the destination airport.

When you insert a STAR for an airport that is not the destination airport in the flight plan, the Navigator will replace the original destination airport with the airport associated with the STAR you selected.

When you insert an Approach, the navigator places it at the end of the flight plan, replacing the destination airport.

To add a procedure to a flight plan:

- Use the **FPL** key and selector knobs to choose the desired flight plan.
- Press **ENT** to get the flashing ++ symbols.
- Use the **0** knob to select the edit point in the flight plan.
- Press **ENT**.
- Use the **0** knob to select a procedure category.

- Press **ENT** to get to the procedure selection page.



If the departure or destination airport does not have a procedure of the type you selected, the Navigator displays a message stating the fact. Press **FPL** to return to editing or **ENT** to choose a procedure from another airport (note the rules mentioned above).

- Select the procedure.
- Press **FPL** to insert the procedure into the flight plan.
- Repeat the insert and replace/delete steps as necessary.
- Press **FPL** to quit the editing session.

TRIMBLE 2101 Approach Plus

5.4.3 *Replace or Delete a Procedure*



To replace or delete a procedure in a stored or active flight plan:

- Use the  key and selector knobs to choose the desired flight plan.
- Press  to get the flashing ++ symbols.
- Use the  knob to move to any portion of the procedure.



When in the procedure, the display flashes:

“REPLCE” “STAR” or “SID” or “APRCH”

To Replace the procedure:



- Press  .
- Select a new procedure.
- Press  to insert the procedure in place of the old.

To Delete the procedure:

- Use the  knob to select “DELETE”.
- Press  to delete the procedure.
- Press  to quit the editing session.

5.4.4 *Editing a SID or STAR Procedure*

To edit a SID or STAR procedure in a stored or active flight plan:

- Use the  key and selector knobs to choose the desired flight plan.
- Press  to get the flashing ++ symbols.
- Use the  knob to move to any portion of the procedure.

When in the procedure, the display flashes:

“REPLCE” “STAR” or “SID”

- Rotate the  knob until the display flashes “EDIT”,

“STAR”, or “SID”.

- Press  to display the ++ symbol.
The procedure is now broken into individual waypoints.
- Edit the waypoints as desired. Reference the *Insert, Replace, or Delete Waypoints* section of this manual.

5.5 Review Legs of a Flight Plan

The Legs page of the Active and Stored Flight Plans mode provide bearing, distance, and ETE for each leg of the flight plan. ETE is based on current ground speed.

For stored flight plans, legs are named LEG 1, LEG 2, ...



For the active plan, legs are named LAST 2, LAST 1, NOW, NEXT 1, NEXT 2...

To view the bearing and distance of any leg in any stored or active Flight Plan:

For Active Plan legs:

- Press  twice (FPL key is flashing).
- Use either knob to move between legs.



For Stored Plan legs:

- Press  twice, unless there is an active FPL, then press it three times to get to STORED FLIGHT PLANS.
- Use the  knob to select a stored flight plan.
- Press  (FPL key is flashing).
- Use either knob to move between legs.



5.6 Reversing a Flight Plan

You may reverse any stored flight plan. If the flight plan contains SID, STAR, or APPROACH procedures, these procedures are automatically replaced with the associated airport as part of the reversal process.

To reverse the order of any stored flight plan:

- Select a stored flight plan.
- Rotate the  knob left until the flashing word REVERSE is displayed.
- Press .

5.7 Activating a Flight Plan

You may activate a flight plan on any of its legs or direct-to any of its waypoints. After you have built or recalled the desired flight plan, use the  knob to view the legs. Use the  key to activate the plan.



Activating a new flight plan automatically cancels an existing active flight plan. You do not have to cancel the old one manually to activate a new one.

You have two choices when activating a flight plan:

- Join the displayed leg.
- Fly direct to either waypoint in the leg.





5.7.1 Join a Flight Plan Leg

To join a leg of a stored flight plan:

- Select a stored flight plan.
- Rotate the  knob clockwise to select the desired leg.
- Press  once and note the leg's course.
- Press  a second time to join the leg and activate the procedure.

5.7.2 Direct-to a Flight Plan Leg

To fly direct-to any waypoint of a stored flight plan:

- Select a stored flight plan.
- Use the  knob to select the leg with the desired waypoint.
- Press  once.
- Use the  knob to select the desired waypoint; left to select the first waypoint of the leg, right to select the second.
- Note the course to the waypoint. Use the  knob to change the course, if desired.
- Press  a second time to fly direct to the waypoint and activate the procedure.

5.8 Canceling an Active Flight Plan

There are three ways to cancel the Active Flight Plan:

- Use the Cancel selection from Active Plan mode.
- Activate a different flight plan.
- Use  to select a destination from WPT or NRST mode.



Selecting CANCEL from Active Plan mode leaves the current From and To waypoint while canceling the remainder of the flight plan. Now, the first press of the  key displays NO ACTIVE FLIGHT PLAN.

Activating a flight plan automatically cancels an existing active flight plan. You do not have to manually cancel the old one to activate a new one.



Selecting direct-to any waypoint or procedure from WPT or NRST mode automatically cancels the existing active flight plan.

TRIMBLE 2101 Approach Plus





To cancel an Active Flight Plan:

- Press  to view the Active Plan.
- Rotate either knob left or right until CANCEL is displayed.
- Press  to cancel the flight plan.

5.9 Erasing a Flight Plan

You may erase any stored flight plan. Erasing is a two-key process ( and ), where the second key press gives you the opportunity to change your mind.

To erase a stored flight plan:



- Select a stored flight plan.
- Rotate the  knob left until the flashing word ERASE is displayed.
- Press .
- Note the prompt ERASE FLIGHT PLAN (FPL).
- Press  to confirm and erase.
or
- Press  to abort the erase process.

5.10 Nearest Waypoints and Agencies



The Nearest () Key provides immediate access of up to 20 of the nearest Airports, Approaches, VORs, Agencies, NDBs, Intersections, and User-created waypoints within a 200 nm radius. Waypoints and Approaches are displayed in order of their distance from the aircraft's current position. Nearest SID and STAR procedures are not provided.

The Waypoint and Approach data available in the NRST modes is the same information that is accessed from the WPT modes. Procedures for access to this data, and selection of Waypoints or Approaches, is identical to WPT.

To locate the waypoint or approach that is closest to the aircraft's current position:

- Press  until the desired waypoint category is displayed.
- Rotate the  knob clockwise to view the 20 nearest waypoints.
Each rotation of the knob brings up the next waypoint, in order of proximity to the aircraft's current position.
- To access additional information on the displayed waypoint, rotate the  knob.

For the Approach category:



- Press  .
- Rotate the  knob counterclockwise to place the cursor in the Airport field.
- Rotate the  knob until the desired Airport is displayed (only available Approaches are displayed).

Use  to activate the displayed Waypoint or Approach.





5.11 Holding Patterns

You may fly a holding pattern at any waypoint in the data base. If the holding fix is in the Active Flight Plan, you must instruct the Navigator to Suspend (hold) automatic waypoint sequencing. If you have no Active Flight Plan but are navigating direct-to a waypoint, there is no need to Suspend waypoint sequencing.

5.11.1 Holding at a FPL Waypoint





In order to hold at a waypoint, it must be your TO waypoint. If it is not, use the  key and the  key to make the holding fix the TO waypoint.

To hold at a fix that is in your Active Flight Plan:

- Make sure the desired holding fix is your TO waypoint.
- Press .
- Rotate the  knob right to "SUSPEND".
- Use the  knob to enter the inbound holding course, TO the holding fix. Set your OBS for visual reference. You may use the  key to quickly get the reciprocal of the displayed course.
- Press . Note that the HOLD light is illuminated.

5.11.2 Holding Outside of a Flight Plan

To hold at a waypoint that is not part of an Active Flight Plan:

- Press .
- Use the  knob to enter the inbound holding course, TO the holding fix. Set your OBS for visual reference. You may use the  key to quickly get the reciprocal of the displayed course.
- Press . The HOLD light does not illuminate.

5.11.3 Holding After a Missed Approach

See Section 3.9, How to Fly a GPS Approach, for instructions on holding at the missed approach holding waypoint.

TRIMBLE 2101 Approach Plus

This page intentionally left blank.

Chapter 6

The NAV Key

The  key features two modes:

- NAV
- Waypoint Information

The first press of the key takes you to NAV, the second to Waypoint Information. Additional presses toggle between the two modes. Each mode contains multiple pages.

TRIMBLE 2101 Approach Plus

6.1 NAV Mode

The Primary NAV Page of NAV mode is the most frequently used page in the Navigator. Once you have activated a waypoint or flight plan for navigation, using the  key, the Primary NAV Page provides the information needed to navigate the aircraft along the selected route of flight. The top line displays bearing, distance, and ETE to the current destination. The bottom line displays the built-in CDI, aircraft ground track, and ground speed.

Each line has eight pages available. Some of the data, such as heading and True Air Speed (TAS), is available if you have external air data and heading sources connected. If the option is not available, the data fields contain dashes. Starting with the Primary NAV page and rotating the knobs clockwise, the pages contain:

Top Line

- TO-waypoint name, Bearing, Distance and ETE.
- TO-waypoint ETE and ETA.
- Heading, TAS, and wind if equipped with optional airdata computer, or “—”.
- Heading or “——”, Track and Drift Angle or “——”
- Current Track and recommended altitude (odd or even) **or** Vertical Navigation Profile Information
- Desired Track, Fly left or right to correct cross track error, XTK error.
- MSA and MESA.
- TKE graphic, DTK and Distance to the to-waypoint.

Bottom Line

- CDI, Track and Ground Speed.
- Current Track and recommended altitude (odd or even) **or** Vertical Navigation Profile Information
- Heading, TAS, and wind if equipped with optional airdata computer, or “—”.
- Heading or “——”, Track and Drift Angle or “——”.
- MSA and MESA.
- TO-waypoint ETE and ETA.
- Desired Track, Fly left or right to correct cross track error, XTK error.
- Advisory Waypoint range and bearing.

6.1.1 NAV Displays

These illustrations depict the NAV Mode displays for the top and bottom lines respectively, corresponding to the order in which they appear (clockwise).

Top Line Displays

LAXA 124° 227M 0:54

ETE 0:54 ETA 3:53z

125° 255° 134°/005°

124° 227M

125° 124° 001° L

MSA 53° MESA 105°

124° MAINTAIN EVEN

or

122° FLY↑000° ↑001M

AT 125 FOR 53 ↓ 600F

Bottom Line Displays

124° 250°

124° MAINTAIN EVEN

or

LAXA 124° 227M 0:54

AT 125 FOR 53 ↓ 600F

122° FLY↑000° ↑001M

125° 255° 134°/005°



ETE 0:54 ETA 3:53z

125° 124° 001° L

MSA 58° MESA 105°



TRIMBLE 2101 Approach Plus

You may create various display combinations from these pages.

The  selector knob controls the top display line. The  selector knob controls bottom display line. If you leave NAV mode, the last pages viewed are displayed when you return.



Press and hold  for 1 second to restore the pages to power-on settings.

To change the NAV mode display:





- Press .
- Use the  knob to select the desired top line display.
- Use the  knob to select the desired bottom line display.

6.1.2 Advisory Waypoint

The Navigator features an Advisory Waypoint page available on the bottom line of the Primary NAV mode display. This page displays range, bearing and ETE to the last waypoint viewed in either WPT or NRST. Use this feature to monitor your position relative to any waypoint in the database without altering your

flight path. Note that any time you use the  or  key, the last waypoint you viewed is the Advisory Waypoint.

To use the Advisory Waypoint feature:

- Select the waypoint from  or .
- Press .
- Rotate the  knob one click left.

6.1.3 The Time Display

The Navigator determines Estimated Time En route (ETE) and Estimated Time of Arrival (ETA) for the TO waypoint and for each waypoint in the active flight plan along the flight path. Times to the TO waypoint are available from the primary NAV page.

ETE to the TO waypoint:

↳SF0A 009° 220M 1:15

ETE and ETA to the TO waypoint:

ETE 1:15L ETA 14:24L

Flight Plan Leg times are available under the second NAV page.

↳SF0A 14:24L 1:15

Flight plan leg ETE is also available under the second FPL page when a flight plan is active. See the FPL section for details.

Total time and distance through the active flight plan is available under the second NAV page by going to the last waypoint in the flight plan.

If your installation provides True Air Speed (TAS) and Heading inputs to the Navigator so that wind is available, the Navigator computes these times based on current TAS and computed wind. In this type of installation, the symbols “--:--” may be displayed for some leg ETEs if you are flying at low airspeeds in high winds, such that the wind velocity is greater than TAS. In this circumstance, the wind is preventing any forward progress along the desired track.

NOTE

Wind and time information under the CALC page are computed using current ground speed or pilot-entered ground speed; they are not corrected for wind.

6.1.4 The Vertical Navigation Display

Vertical Navigation (VNAV) Profiles display descent or climb information to the active waypoint as entered under the **CALC** key. Instructions for entering VNAV information are described in Section 7.5.

If the aircraft is not yet at the descent or climb starting point, or if you have not entered VNAV information, the following is displayed under the **NAV** key:

```
TRK 124° MAINTAIN ODD
```

The current track is 124°. Maintain ODD altitude based on VFR/IFR altitude rules.

If you have entered VNAV information, the following will be displayed under the **NAV** key when you reach the climb or descent starting point:

```
AT 125 FOR 53 ↓ 600f
```

This indicates your altitude is 12,500 feet, the target altitude is 5,300 feet and you should descend at 600 feet per minute to reach the desired altitude.

During the climb or descent, the navigator will provide several messages. These include when to begin the climb or descent, the time to the target altitude and when to level off. When the MSG annunciator light flashes, press **MSG** to view these messages.

6.2 Ground Track Displays

The Ground Track pages in NAV mode provide information on the desired track (DT), the ground track (TK), track error (TKE), and the distance off-track, in both graphic and numeric formats.

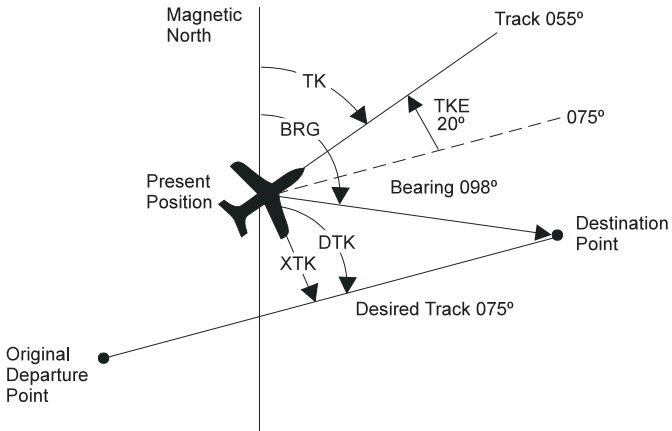

6.2.1 Track Error Graphic Display

The Track Error (TKE) Display is available in graphic form on both the top and bottom lines of the primary NAV display (press the NAV button for approximately one second until display defaults to primary NAV mode.) The top line TKE graphic provides information on TKE only and is available at any time. The bottom line TKE graphic provides information on both CDI and TKE simultaneously (unless your installer has disabled this feature during setup).

Scaling is 10° per mark except when the approach annunciator is on, in which case scaling is 5° per mark.

For a CDI-only graphic on the lower line of the display, the CDI symbol (the vertical line representing the Course Deviation) is seven pixels high, and extends the entire height of the LED cell. For the combined TKE/CDI graphic, the CDI symbol is a vertical line five pixels high (top five), while the TKE symbol is a vertical line two pixels high (bottom two).

TRIMBLE 2101 Approach Plus

To access the top line TKE graphic from the primary NAV display:

- Rotate the  counterclockwise one click.

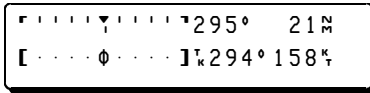

The scale on the top line provides TKE graphic information of aircraft nose position relative to desired track. The moving symbol is not a fly-to symbol, but rather an indication of current nose position. Bearing to the Active Waypoint and distance-to-go are also displayed on the top line. The CDI located on the bottom line is a fly-to symbol and provides course deviation left and/or right of desired track.

The following display illustrates the combined CDI/TKE graphic found on the primary NAV page.

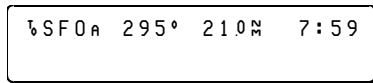

When the CDI symbol and TKE symbols are coincident, standard course intercept is being flown as described below.

To smoothly intercept the desired track represented by the location of the CDI indicator, turn the aircraft toward the CDI fly-to symbol until the TKE symbol is located directly under the CDI symbol. Maintaining this relationship throughout the intercept will result in a shallowing of the intercept angle. To increase the rate of intercept, merely oversteer the TKE symbol relative to the CDI indicator.

6.2.2 CDI Display

6.2.2.1 Cross-Track Errors – Ground Track

The internal CDI simulates a mechanical course deviation indicator. When the flashing vertical bar is centered on the \emptyset , the aircraft is on course. If the flashing bar is to the left or right of the \emptyset , a cross-track error is occurring. To correct the error, fly towards the “needle” as in conventional VOR navigation.

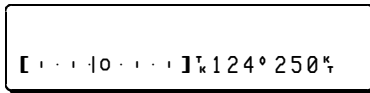

If the cross-track error is greater than the full scale setting of the CDI, the left or right bracket will change to a flashing arrow, indicating the direction to steer to center the CDI. Additionally, the cross-track error distance will be displayed numerically in nautical miles (nm), statute miles (sm), or kilometers (km) (the units used depend on how the installer configured the unit). If cross-track error is greater than 9.9, it will be displayed as a whole number up to 99. The following figure illustrates a cross-track error of 2.6 nm, with an internal CDI sensitivity setting of 1.0 nm full scale.

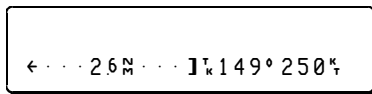

TRIMBLE 2101 Approach Plus

6.2.2.2 CDI Scale

Each mark on the Navigator CDI (\emptyset , vertical bar, or dot) corresponds to one dot on the external CDI. Scaling is automatically controlled by the Navigator at 5.0 nm en route, 1.0 nm terminal, and 0.3 nm during the approach.

The example below shows the en route mode display when the scaling is 5 nm. Each bar represents 1.0 nm.



Below is the terminal mode display when the scaling is 1 nm. Each dot represents 0.2 nm.

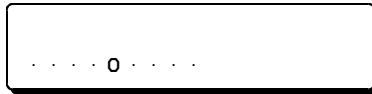

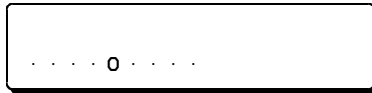

The display below illustrates approach mode with scaling of 0.3 nm and the APR annunciator ON. Each dot represents 0.06 nm.



If the internal CDI was configured at installation for 2.5 nm full scale, the en route display looks like the one below. Each bar represents 1 nm.



6.3 Waypoint Information Mode



Pressing the NAV key twice accesses the waypoint information pages. These pages display information about the Active Flight Plan waypoints. Use the  knob to move through the waypoints on the top line. Use the  knob to view the available information about the waypoint.

Some information is computed “through the flight plan”. For example, distance through the flight plan is computed by adding the distance of each leg of the flight plan from present position to the selected waypoint, as opposed to the distance direct from present position to the selected waypoint.

The Navigator displays times (ETE and ETA) that are corrected for wind speed and direction when wind is available. See 6.1.3.

You can fly direct-to any waypoint displayed in this mode with the  key.

To access the NAV Waypoint Information mode displays:

- Press  to get to WAYPOINT INFORMATION.
- Use the  knob to select the desired active plan waypoint.
- Use the  knob to select the desired information display.

Turning the  knob left one click displays:

- Bearing and direct distance to the WPT on the top line and distance and ETE to the waypoint through the flight plan on the bottom line. Distance is displayed as dashes (---) for waypoints you have passed.

Turn  left one more click to access:

- ETA and ETE to the waypoint through the flight plan.
- Fuel remaining at the waypoint.
- Fuel needed to reach the waypoint, through the flight plan.

TRIMBLE 2101 Approach Plus

Turn the  to the right to display information about the waypoint.

See “The Waypoint Displays” for details about these pages.

Chapter 7

The Calculator Key

The **CALC** key allows you to perform many common E6B computer functions and other calculations.

The **CALC** key features three modes:







- Flight Plan/Fuel
- Air Data
- Save Present Position

This chapter covers the following topics available with the calculator key:

- Time, Distance, and Speed
- Fuel Management
- Winds Aloft
- Pressure Altitude
- Density Altitude
- True Airspeed
- Crosswind and Head Wind
- Save Present Position

7.1 Entering Data in the CALC Mode

In general, to enter information and perform calculations in the CALC mode:

- Press  to access the desired CALC mode.
- Rotate the  knob to move to the desired page.
- Press .
- Rotate the  knob to move to the desired field.
- Rotate the  knob to change information in a field.
- Continue this procedure until all information is entered.
- Press  to complete the entry.

When one field is updated, all pages containing that field reflect the current information.

All the CALC mode displays (except Pressure Altitude page) use data provided by the Navigator or external sensors. When manually editing data, returning to NAV mode erases the changes.

7.2 Flight Plan/Fuel Pages

Flight Plan calculations are available in the Fuel Management and Time, Distance, and Speed pages. These pages show current flight plan data and information when available. They may also be used as a flight planning calculator.

If you are flying an Active Flight Plan, these pages use the current ground speed and external fuel computer or user-entered rate of fuel consumption to compute the following:

- Estimated Time En route (ETE)
- Estimated Time of Arrival (ETA)
- Flight Plan Distance (DIST)
- Rate of Fuel Consumption

The Fuel Management and Time, Distance, and Speed pages also estimate the amount of fuel required to arrive at the current destination. If you are flying a multi-leg flight plan, the data reflects calculations from present position through the flight plan to the final destination.

7.2.1 Time, Distance and Speed Calculations

To display the Time, Distance and Speed page:

- Press **CALC** to access the FLT PLAN/FUEL mode.
- Rotate the **⦿** knob to display the Time, Distance and Speed page.

The Time, Distance, and Speed page shown below indicates the flight plan ground speed is 160 knots; flight plan distance is 191 nautical miles; the flight plan time (ETE) is 1 hour and 11 minutes; the estimated time of arrival (ETA) is 9:25 local time.

FPL	GS	160	ETE	1:11
DIST		191		9:25L



All the fields displayed (except ETA) may be edited at any time for different flight plan calculations.

Distance, ground speed, and ETE may be manually edited to view different flight plan data. The following chart shows how each changed field initiates new calculations:

<u>Changed Field</u>	<u>Calculation Affected</u>
ETE	Distance, ETA
Distance	ETE, ETA
Ground Speed	ETE, ETA

TRIMBLE 2101 Approach Plus

To edit a field in the Time, Distance and Speed page:

- Press **ENT** .
- Rotate the  knob to move through the editable fields.
- Rotate the  knob to change the data in the selected field.
- Press **ENT** to accept the changes.

NOTE

Wind and time information under the CALC page are computed using current ground speed or pilot-entered ground speed; they are not corrected for wind.

7.2.2 Fuel Management Calculations

To display the Fuel Management page:



- Press **CALC** to access the FLT PLAN/FUEL mode.
- Rotate the  knob to display the Fuel Management page.

The Fuel Management page below indicates that the estimated fuel required to reach the destination is 14.5 gallons; fuel consumption rate is 12.3 gallons per hour; and fuel efficiency is 13.0 nautical miles per gallon. The fuel consumption rate is taken from the Air and Fuel Data Computer input, if available, or from user input.

FUEL	↕	DEST	14.5GAL
FLOW	12.3GH	13.0MPG	

The fuel required and current fuel consumption rate fields may be edited. These changes affect the distance field of the previous page. The fuel required field displays the fuel needed to reach your destination at current GS and consumption rate. The fuel efficiency is always computed by using the ground speed from the Time, Distance, and Speed page. This is the aircraft's current ground speed unless a new value has been entered.

For flight planning, you can determine the maximum remaining flight range and fuel efficiency. Enter the remaining usable fuel and current fuel consumption rate as follows:

- Press **ENT**.
- Rotate the  knob to move through the editable fields.
- Rotate the  knob to change the data in the selected field.
- Press **ENT** to accept the changes.

The DIST field on the previous page changes, showing the maximum remaining flight range.

<u>Changed Field</u>	<u>Calculation Affected</u>
Fuel	Distance (previous page)
Rate	Distance, MPG
Distance	Fuel

Editing the fuel or rate of consumption fields results in changed values as shown below:

Distance can be edited on the Time, Distance, and Speed page. Changing or computing a value on one page automatically changes the other page, but does not affect current flight data.

Fuel management calculations are based on the information the

TRIMBLE 2101 Approach Plus

7.2.3 Fuel Remaining Page

The initial fuel on board is entered during the power-up sequence. The Navigator keeps track of Fuel Remaining, based on fuel rate information from the Air and Fuel Data Computer, if one is used, or from user input.

To display the Fuel Remaining page:

- Press **CALC** to access the FLT PLAN/FUEL mode.
- Rotate the **⦿** knob to display the Fuel Remaining page.

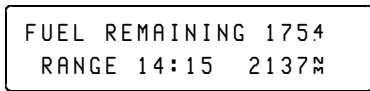

FUEL REMAINING 1754
RANGE 14:15 2137M

The Fuel Remaining page provides the following information:

- Fuel Remaining (initial fuel minus fuel used)
- Flight Time Remaining (fuel remaining divided by fuel consumption rate)
- Range (flight time remaining times ground speed)

To edit the Fuel Remaining field:

- Press **CALC** to access the FLT PLAN/FUEL mode.
- Rotate the **⦿** until you reach the Fuel Remaining Page.
- Press **ENT**.
- Use the **⦿** to change the value in the fuel remaining field.
- Press **ENT** to accept the changes.

7.2.4 Fuel At Arrival Page

To display the Fuel at Arrival page:

- Press **CALC** to access the FLT PLAN/FUEL mode.
- Rotate the **●** knob to display the Fuel at Arrival page.

The Fuel At Arrival page provides the following information:

- Fuel At Arrival (fuel remaining minus fuel used)
- Flight Time Reserve (Fuel at Arrival divided by Fuel Consumption Rate)
- Reserve (flight time reserve times ground speed)

FUEL @ ARRIVAL	53.3
RESERVE	4:28 671M

The Navigator calculates the amount of fuel that will be available on board when the aircraft reaches its final destination. This display provides the pilot with the necessary information to evaluate the reserve fuel situation early enough to take necessary action.

7.2.5 Minimum Fuel Page

The Minimum Fuel Page features two editable fields used by the Navigator to warn you of impending fuel quantity shortages.

To display the Minimum Fuel Page:

- Press **CALC** to access the FLT PLAN/FUEL mode.
- Rotate the **●** knob to display the Minimum Fuel page.





MIN. FUEL IN MINUTES
ON BOARD 30/@DEST 45

TRIMBLE 2101 Approach Plus

The ON BOARD value is used by the Navigator to display the Fuel Exhausted message when the flight time remaining (at the current ground speed and burn rate leaves you less than 30 minutes of fuel at your destination.



The @DEST value is used by the Navigator to display the Using Fuel Reserve message when the flight time remaining (at the current ground speed and burn rate) leaves you less than 45 minutes of fuel reserve at your destination.

To change the time of the Fuel Reserve message or the Fuel Exhausted message:

- Press .
- Rotate the  knob to move through the editable fields.
- Rotate the  knob to change the setting.
- Press  to save the changes.

7.2.6 Total Fuel Used Page

To display the Total Fuel Used page:

- Press  to access the FLT PLAN/FUEL mode.
- Rotate the  knob to display the Total Fuel Used page.

The Total Fuel Used page provides the following information:

- Total Fuel Used
- Total Used by Left Engine
- Total Used by Right Engine

TOTAL USED	412
LEFT 19.8 RIGHT	21.4

The Navigator keeps track of the fuel used since the last fuel entry. When installed in a single engine aircraft, or without an Air and Fuel Data Computer, the second line (Left and Right Engine usage) is not displayed.

When the Navigator is turned off, the Fuel Used is reset to zero. The Fuel Remaining is not reset. This feature is useful for multi-stop flights where the fuel used for each leg may be monitored while keeping track of the total fuel remaining.

7.2.7 Engine Fuel Flow Page

To display the Engine Fuel Flow page:

- Press **CALC** to access the FLT PLAN/FUEL mode.
- Rotate the  knob to display the Engine Fuel Flow page.



FUEL % DEST 20 GAL
FLOW 14.1GH 105#PG

The Navigator provides a digital readout of the engine fuel flow quantity to a tenth of a unit per hour. (The units displayed (gallons, liters, or pounds) depend on the setup of the Navigator.) This page is not displayed when the Navigator is installed in a single engine aircraft or when there is no Air and Fuel Data Computer. (Total fuel flow information is available on the main Fuel Management page; see Total Fuel Page).



7.3 Air Data Pages

Air data calculations are available in the Air Data pages. Use these to compute:

- Altitude
- TAS
- Wind

7.3.1 Pressure Altitude Calculations

To access the Pressure Altitude mode:

- Press  to access the Air Data mode.
- Rotate the  knob to display the Pressure Altitude Calculation page.

The Pressure Altitude page provides the following information:

- Pressure Altitude
- Barometric Pressure Setting
- Indicated Altitude

Pressure Altitude and Indicated Altitude are measured in thousands of feet or thousands of meters, depending on the setting of the unit in use.

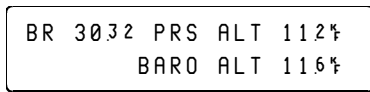

Barometric Pressure Setting is measured in inches of mercury, from 28.00 in. to 31.00 in. or in millibars, from 948 mb to 1050 mb, depending on the setting of the unit in use.

In the example below, the Pressure Altitude page indicates that the barometric pressure setting is 30.32 inches of mercury, the pressure altitude is 11,200 feet, and barometric altitude is 11,600 feet.



```
BR 30.32 PRS ALT 11.2k
BARO ALT 11.6k
```

To enter the information required for pressure altitude calculations:

- Press **ENT** .
- Rotate the  to move through the editable fields.
- Rotate the  to change the data in the selected field.
- Press **ENT** to accept the changes.

A change in barometric setting or indicated altitude initiates new calculations in related fields, according to the chart below:

<u>Changed Field</u>	<u>Calculation Affected</u>
Barometric Setting	Pressure Altitude
Indicated Altitude	Pressure Altitude

Changes made for pressure altitude will be reflected in the Density Altitude and TAS displays.

7.3.2 Density Altitude Calculations

- Press **CALC** to access the Air Data mode.
- Rotate the  knob to display the Density Altitude Calculations page.

The Density Altitude page provides the following information:



- Density Altitude in thousands of feet or thousands of meters.
- Ram Air Temperature (degrees Celsius) - the Total Air Temperature as indicated on an uncorrected temperature probe (typically labeled OAT in light aircraft and RAT in corporate/commercial aircraft. See True Airspeed Calculations section for a complete definition).
- Pressure Altitude in thousands of feet or thousands of meters.

TRIMBLE 2101 Approach Plus

In the example shown below, the Density Altitude page indicates that density altitude is 13,300 feet; the Ram Air Temperature (Total Air Temperature) is 19° Celsius; pressure altitude is 10,500 feet.

```
DENSITY ALTITDE 13300
RAT 190 PRS ALT 10500
```

To enter the information required for density altitude calculations:

- Press **ENT**.
- Rotate the  knob to move through the editable fields.
- Rotate the  knob to change the data in the selected field.
- Press **ENT** to accept the changes.

A change in either RAT or pressure altitude initiates new calculations in related fields, according to the chart below:

<u>Changed Field</u>	<u>Calculation Affected</u>
RAT	Density Altitude
Pressure Altitude	Density Altitude
Density Altitude RAT	

7.3.3 True Airspeed (TAS) Calculations

- Press **CALC** to display the Air Data mode.
- Rotate the  knob to access the True Airspeed Calculations page.

The True Airspeed page provides the following information:

- True Airspeed in knots, statute miles per hour, or kilometers per hour.
- Outside Air Temperature (OAT, degrees Celsius) the True Air Temperature of the ambient corrected for temperature rise, compressibility, etc.
- Mach Number (non-dimensional) True Airspeed divided by Speed of Sound at current Pressure Altitude.
- Indicated Airspeed in knots, statute miles per hour, or kilometers per hour.
- Ram Air Temperature (RAT, degrees Celsius) - the Total Air Temperature as indicated on an uncorrected temperature probe .





For an Indicated Airspeed of 321 knots, Ram Air Temperature of +14° C, and a Pressure Altitude of 20,000 feet (not displayed on this page), the True Airspeed page shown below indicates that the True Airspeed is 438 knots, true Outside Air Temperature is -11° C, and Mach number is .69.

TAS 438 ^k OAT -11 ^c M.69
IAS 321 ^k RAT 14 ^c

OAT and TAS presented on the CALC-TAS page are dependent on the “K” Factor used in the initial configuration of the unit. This “K” Factor only applies to the standard Ram Air Temperature gauge located on the instrument panel and is only used to determine the true Outside Air Temperature (OAT) for manual TAS calculations as described below. When an Air Data Computer (such as the Shadin ADC 200) is installed in the aircraft, displayed ADC parameters generally are based on a “K” Factor of 1.0.

TRIMBLE 2101 Approach Plus

To enter the information required for true airspeed calculations:

- Press  .
- Rotate the  knob to move through the editable fields.
- Rotate the  knob to change the data in the selected field.
- Press  to accept the changes.



For manual calculations, ensure that the desired Pressure Altitude has been entered on the previous CALC page.

A change in IAS, RAT, TAS, OAT, or Mach initiates new calculations in related fields, according to the chart below:

<u>Changed Field</u>	<u>Calculation Affected</u>
IAS	TAS, OAT, Mach
RAT	TAS, OAT
TAS	OAT, Mach, IAS
OAT	TAS, RAT
Mach	TAS, OAT, IAS

Changes made in TAS calculations will be reflected in the Winds Aloft calculations.

7.3.4 Winds Aloft Calculations

- Press  to access the Air Data mode.
- Rotate the  knob to display the Winds Aloft Calculations page.

The Winds Aloft page provides the following information:

- Wind Direction and Speed
- True Airspeed and Heading



The Winds Aloft page shown below indicates that the wind is from 25° true at 28 knots, given a true airspeed of 153 knots and a heading of 070°. Wind direction is given in degrees TRUE, not degrees magnetic.

WIND	↵	25°	↵	at	28↵
TAS		153↵	HDG		70°

This page determines the winds aloft based on

- (1) the current track and ground speed from the NAV page,
- (2) magnetic variation,
- (3) the TAS from the TAS page, and
- (4) the manually-entered HDG, or the current heading from the aircraft's compass system

To enter information required for Winds Aloft calculations:



- Press **ENT** .
- Rotate the  knob to move through the editable fields.
- Rotate the  knob to change the data in the selected field.
- Press **ENT** to accept the changes.

A change in either the TAS or heading fields initiates new calculations in related fields, according to the chart below:

<u>Changed Field</u>	<u>Calculation Affected</u>
TAS	Wind Speed, Wind Direction
Heading	Wind Speed, Wind Direction

TRIMBLE 2101 Approach Plus

7.3.5 Crosswind and Head Wind Calculations

- Press  to access the Air Data mode.
- Rotate the  knob to display the Crosswind and Head wind Calculations page.

The Crosswind and Head wind page provides the following information:



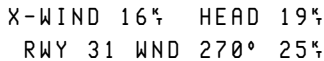

- Crosswind
- Head wind
- Runway Direction
- Wind Direction (magnetic) and Speed

The Crosswind and Head wind page shown below indicates that the crosswind component is 16 knots; the Head wind component is 19 knots for runway 31, when the wind is from 270° True at 25 knots.



```
X-WIND 16kts  HEAD 19kts
RWY 31  WND 270° 25kts
```

To enter the information required for crosswind and head wind calculations:

- Press .
- Rotate the  knob to move through the editable fields.
- Rotate the  knob to change the data in the selected field.
- Press the  key to accept the changes.

A change in either the runway number, wind direction or wind speed initiates new calculations in related fields, according to the chart below:

<u>Changed Field</u>	<u>Calculation Affected</u>
Runway Number	Crosswind, Head wind
Wind Direction	Crosswind, Head wind
Wind Speed	Crosswind, Head wind

7.4 Saving the Present Position

The Save Present Position mode is used to save the aircraft's present position. The Navigator provides 10 phonetic waypoints, alpha-juliet, for temporary storage of present position waypoints. Each time you save present position, the Navigator stores the position in the next phonetic waypoint, overwriting that waypoint. After 10 consecutive saves, the alpha waypoint is overwritten.



To save a present position:

- Press **CALC** to access the Save Present Position Mode.
- Press **ENT** to save the present position.

PRESS (ENT) TO SAVE
POSITION TO alpha

7.4.1 Copy a Phonetic Waypoint

You may save any phonetic waypoint by copying it to a user waypoint.

- Press **WPT** until you get to the USER mode.
- Use the  knob to view the phonetic waypoint of interest. For example, chrly.
- Rotate the  knob one click either direction to display "EDIT chrly? (ENT)".
- Press **ENT**.
- Use the selector knobs to change the name.
- Press **ENT**.

7.5 Vertical Navigation Profiles

Vertical Navigation (VNAV) can be used for climb or descent profiles. The Navigator creates a VNAV profile to the active waypoint based on the current ground speed.

The calculation is made using a pilot-entered starting altitude, ending altitude, desired rate (or angle) of descent or climb, and the desired distance from the active waypoint for the ending altitude. Using this information, the Navigator calculates the VNAV descent or climb starting point and the altitude required to follow the profile.

Press **MSG** to display the advisory messages indicating when the level-off point has been reached.

The illustration below shows a descent is from 12,500 feet to 10,500 feet at a rate of 200 feet per minute. The active waypoint is the Santa Monica VOR at 10,500 feet.

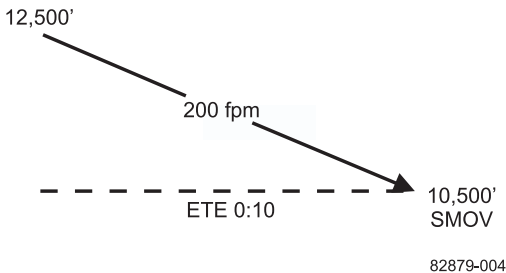

To enter VNAV profile information:

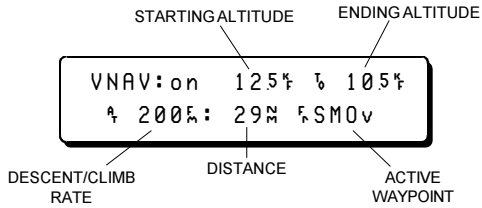

- Press **CALC** to access the NAV Profile mode.
- Press **ENT**.
- Rotate the **⦿** clockwise to turn VNAV on.
- Rotate the **⦿** to move to the next editable field.
- Use the **⦿** to change the starting altitude.
- Use the selector knobs to continue moving through and changing the editable fields.
- Press **ENT** to save the changes.



View VNAV Profile information under the **NAV** key.

TRIMBLE 2101 Approach Plus



This Page Intentionally Left Blank

Chapter 8

The Auxiliary Key

Use the  key to control and monitor information in the Navigator. The  key features five modes:

- Checklist
- System Status
- Sensor Status
- Configure
- User Setup

Once the desired mode is selected, rotate the  and  knobs to access additional information displays.

TRIMBLE 2101 Approach Plus

Auxiliary Mode Features

Checklist

User entered checklists, Custom Data, Commonly Used Frequencies, etc.

System Status

Date/Time, Present Position, System Operating Conditions, Data Base, and Software Revisions.

Sensor Status

GPS Status and Accuracy, Satellite Data, GPS Availability, Approach RAIM Availability.

Configure

Parallel Offset, Dead Reckoning/Demo Mode, Display Diagnostic.

User Setup

If this mode is available, it will include Search Regions, Airwatch, Safeguard/Personal Message, Save/Load Configuration.

8.1 The Checklist Mode

Use the checklist mode to create up to 10 custom checklists with up to 26 entries each.

8.1.1 Creating and Naming Checklists

To create and name a customized checklist:



- Press **AUX** to access the Checklist mode.

The checklist message flashes on the screen and then the title for the last selected checklist is displayed. If no checklists have been created, the Navigator displays:

NO CHECKLISTS

- Rotate the  knob until the following display appears:



0: INSERT AT START
INSERT LIST 0 (ENT)

- Press **ENT**.
- Rotate the  knob to select the first letter or number in the name field.
- Rotate the  knob to move to the next space in the field and select the next character using the  knob.
- Continue this process to finish the entry.
- Press **ENT** when the entry is complete.

TRIMBLE 2101 Approach Plus

The checklist number is listed on the top line of the display shown below. The first item in the list, A, is listed on the bottom line.

```
INSERT 0A      (ENT)
A:
```



- Press **ENT** .
- Rotate the  knob to select the first letter or number of the checklist item.
- Rotate the  knob to move to the next space in the field and select the next character using the  knob.
- Continue this process to finish the entry.
- Press **ENT** when the entry is complete.

The Navigator will display:

```
INSERT 0B      (ENT)
B: INSERT AT END
```

Continue this process until all items (up to 26) are entered in the checklist. Press the **AUX** key to store the checklist.

To enter another checklist:

- Rotate the  knob until the bottom line of the Navigator displays “INSERT LIST 0 (ENT)”.
- Rotate the  knob until the Navigator displays:

```
1: INSERT AT END
INSERT LIST 1 (ENT)
```

- Press **ENT** and enter a new checklist as described previously.

8.1.2 Using a Checklist

You can access a checklist at any time during flight.

To activate a checklist:

- Press **AUX** to access the Checklist mode.
- Rotate the  knob to select the desired list.



To check off the first item in the list:

- Press **ENT** .



A check mark appears next to the item and the Navigator displays the next item on the list. After all the items on the list have been checked off, a check mark is displayed next to the list name.

Rotate the  knob to go to the next list.



You may exit the Checklist mode at any time by pressing any key. When you return to the Checklist mode, the Navigator returns to the last checklist displayed. You can proceed with checking off items as though there had been no interruption. The check marks will remain until the Navigator is powered down.

TRIMBLE 2101 Approach Plus

8.1.3 Editing a Checklist



Once a checklist is created, you can edit the checklist name or any of the items in the list.

To edit an entry in a checklist:

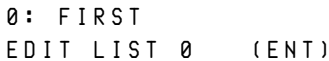
- Press **AUX**.
- Rotate the  knob to select the list to be edited.
- Rotate the  knob until the Navigator displays the “EDITLIST” option:



```
0: FIRST
EDIT LIST 0 (ENT)
```

- Press **ENT**.
- Rotate the  knob to select the item in the checklist or the checklist title to be edited.
- Press **ENT**.
- Rotate the  knob to change the character.
- Rotate the  knob to move the cursor to the next character.





```
EDIT 0 TITLE (ENT)
0: TAKEOFF
```

- Continue this process to finish updating the entry.
- Press **ENT** when the entry is complete.
- Rotate the  knob to select another item in the checklist to edit, or
- Press **AUX** to complete editing.



8.1.4 Inserting and Deleting Checklist Items

Once a checklist is created, you can add or delete items.





To insert a new item into a checklist:

- Press **AUX** to access the Checklist mode.
- Rotate the  knob to select the list to be edited.
- Rotate the  knob until the “EDIT LIST” message is displayed.



- Press .
- Rotate the  knob until the Navigator displays:







- Rotate the  knob to select the position in the checklist in which to insert the new item.
- Press .
- Using the selector knobs, enter the new item.
- Press .
- Edit more items or press  to complete editing.

The new item is inserted into the checklist as the new item B. The former item B and all the following items move down one position.

TRIMBLE 2101 Approach Plus

To delete an item from the checklist:

- Press **AUX** to access the Checklist mode.
- Rotate the  knob to select the list to be edited.
- Rotate the  knob until the “EDIT LIST” message is displayed.
- Press **ENT**.
- Rotate the  knob to select the item in the checklist to delete.
- Rotate the  knob until the Navigator displays:
- Press **ENT** to delete the item.

```
DELETE 0C      (ENT)
C: ALTIMETER
```



- Press **AUX** to confirm the deletion. (Press any other key to abort the deletion process.)

When an item is deleted from a checklist, all the remaining checklist items move up one position.

8.1.5 Deleting a Checklist

Once a checklist is created, the checklist may be deleted.

To delete a checklist, follow these steps:

- Press **AUX** to access the Checklist mode.
- Rotate the  knob to select the list to be deleted.
- Rotate the  knob until the “DELETE LIST” message is displayed.



```
2: LANDING
CONFIRM DELETE (AUX)
```

- Press **ENT**.
- Press **AUX** to confirm the deletion.

When a checklist is deleted, all the lists that follow move up one position.

8.2 The System Status Mode

The System Status mode provides quick access to system status information. The six status pages include the following:

- Date/Time Display
- Present Position/Latitude and Longitude Information
- Voltage and Internal Temperature Display
- Database Expiration Information
- Software Revision Information
- Software Code Display

8.2.1 The Date/Time Display

The first page in the System Status function displays the local date, Zulu (UTC) time, time zone and local time.

The Time page shown below indicates that the current date is February 28, 1997; the day is Friday; the time is 6:29, the time zone is Pacific Standard Time; the current Zulu time is 14:28:53. When GPS Satellites are available, the time and date are set automatically.

FRIDAY	28-FEB-97
15:04:57z	PST 07:04

Time zones are selected from the following list:



PST	Pacific Standard Time
PDT	Pacific Daylight Savings Time
MST	Mountain Standard Time
MDT	Mountain Daylight Savings Time
CST	Central Standard Time
CDT	Central Daylight Savings Time
EST	Eastern Standard Time
EDT	Eastern Daylight Savings Time
AST	Atlantic Standard Time
ADT	Atlantic Daylight Savings Time

Pre-programmed time zones are not available for International use. For operation outside of North America, enter the time offset from UTC. For example, the time offset for Melbourne, Australia would be UTC + 10.

TRIMBLE 2101 Approach Plus

8.2.2 The Present Position Display

The Present Position page displays the aircraft's current position in one or two coordinate systems.

- Press  to access the System Status mode.
- Rotate the  knob to display the Present Position page.

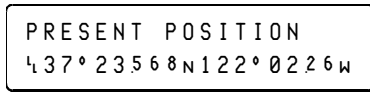



PRESENT POSITION
43.7° 23.568N 122° 02.26W

8.2.2.1 The Altitude Display

The Altitude page displays the current altitude and altitude source. In case of an altitude source failure, use this page to enter a manual altitude for use by the GPS receiver.

To access the Altitude page:

- Press  to access the System Status mode.
- Rotate the  knob to display the Present Position page.
- Rotate the  knob to display the Altitude page.

The Altitude page below indicates the current altitude is 10,253 feet and the source is pressure, with the GPS 3D altitude available as a backup.



ALTITUDE: 10253'
SOURCE: PRS/GPS-3D

Your altitude encoder provides pressure altitude to the Navigator in compliance with TSO C-129. This pressure altitude augments the GPS position and RAIM computations, extending the RAIM coverage in cases where satellite coverage alone is inadequate for 3D position solutions and RAIM. In case of external altitude source failure and 2D GPS operation, you may enter altitude manually. If the external altitude source is valid or the GPS is operating in 3D mode, the Navigator will not accept manual altitude input.

Depending on the GPS mode and the state of the aircraft altitude encoder input, you may see any of these altitude sources:

BARO/GPS-3D

The altitude source is BARO from an Air Data Computer. The GPS is operating in 3D, GPS computed altitude is available.

BARO/GPS-2D

The altitude source is BARO from an Air Data Computer. The GPS is operating in 2D mode, no GPS altitude is available.

PRS/GPS-3D

The altitude source is pressure from the encoder. The GPS is operating in 3D, GPS computed altitude is available.

PRS/GPS-2D

The altitude source is pressure from the encoder. The GPS is operating in 2D mode, no GPS altitude is available.

GPS-3D

The altitude source is GPS 3D computed altitude.

HELD/GPS-2D

The altitude source is held at the last known value. The GPS is operating in 2D mode, no GPS altitude is available.

MANUAL/GPS-2D

The altitude source is your manual entry. The GPS is operating in 2D mode, no GPS altitude is available.





OLD

The Navigator is not receiving external altitude nor computing GPS solutions.



TRIMBLE 2101 Approach Plus

8.2.2.2 Entering Manual Altitude

To enter a manual altitude when the source is HELD, MANUAL or OLD:

- Press  to access the System Status mode.
- Rotate the  knob to display the Present Position page.
- Rotate the  knob to display the Altitude page.
- Press .
- Use the selector knobs to set the altitude.
- Press .

8.2.2.3 Pressure Altitude and GPS Altitude

- Press  to access the System Status mode.
- Rotate the  to display the Present Position page.
- Rotate the  knob to the right to view the current pressure and GPS altitudes.

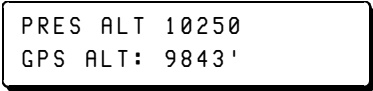

The display below indicates that the current pressure altitude is 10,250 feet. The source is encoder input. GPS altitude is 9,843 feet.



```
PRES ALT 10250
GPS ALT: 9843'
```

When the altitude source is not available, the altitude is displayed as dashes (for either pressure or GPS altitude).

8.2.3 The Voltage and Temperature Display

- Press  to access the System Status mode.
- Rotate the  knob to display the Voltage and Temperature page.



The Voltage and Temperature page below indicates that the input voltage is 14.2 volts; temperature inside the unit is 33° Celsius.



```
INPUT VOLTAGE: 14.2V
INTERNAL TEMP:  33°C
```

8.2.3.1 The Crystal Offset and Memory Battery Display

This page provides maintenance information.

- Press  to access the System Status mode.
- Rotate the  knob to display the Voltage and Temperature page.
- Rotate the  knob to select the Crystal Offset page.

The GPS Receiver Crystal Offset page below indicates that the crystal frequency offset is 13 Hz from nominal and the memory battery is 3.67 volts.





```
CRYSTL OFFSET: 13Hz
MEMORY BATTERY: 3.67v
```

TRIMBLE 2101 Approach Plus

8.2.3.2 The GPS Antenna Display

This page provides maintenance information.

- Press  to access the System Status mode.
- Rotate the  knob to display the Voltage and Temperature page.
- Rotate the  knob to display the GPS Antenna page.

The GPS Antenna page display shown below indicates that the voltage across the antenna leads is currently 4.36 volts and the current is 65 milliamperes.





A rectangular display box with a black border containing the following text:

GPS ANTENNA:	4.36 V
CURRENT:	65 mA

8.2.4 The Database Expiration Display

The Database Expiration page displays the expiration date of the NavData card.

- Press  to access the System Status mode.
- Rotate the  knob to display the Database Expiration page.

The Database Expiration page below indicates that the current database expires on March 25, 1997.



A rectangular display box with a black border containing the following text:

DATABASE EXPIRATION
25-MAR-97

8.2.5 The Software Revisions Display

- Press **AUX** to access the System Status mode.
- Rotate the  knob to access the software revisions page.

The Trimble 2101 Approach Plus GPS Navigator contains two processors, each with its own software code:

- Navigation and I/O Processor
- GPS Processor

The Software Revisions page lists the software revision numbers.

```
REVISION:: NAV2620  
GPS502-0812
```

8.2.6 The System Code Display

- Press **AUX** to access the System Status mode.
- Rotate the  knob to display the System Code page.

The System Code page lists the system revision for the Trimble 2101 Approach GPS Navigator software. This revision number matches the last four digits of the unit part number found on the ID plate.

```
SYSTEM CODE: 0240  
c1997
```

8.3 The Sensor Status Mode

The Sensor Status mode allows quick access to sensor diagnostic information as well as the system navigation mode. The sensor status pages include the following:

- GPS Status
- Estimated Accuracy
- GPS Satellite Status
- GPS Sensor Reset
- GPS Satellite Availability
- Approach RAIM Availability

8.3.1 GPS Sensor Status

The GPS Status page displays current operating mode, RAIM mode, and Position Dilution of Precision (PDOP).

RAIM provides verification that GPS accuracy is sufficient for use as a supplemental means of navigation during IFR En-route, Terminal, and Non-precision Approach operations. In the event "RAIM" status reverts to "NO RAIM", use of GPS for en route navigation is still approved, but must be cross-checked with VOR, DME, etc.

PDOP is a measurement of the geometry of the satellites. The smaller the number, the greater the precision.

To access the GPS Status Display:

- Press **AUX** to access the Sensor Status mode.

The GPS Status page indicates that the GPS receiver is computing position in three dimensions, pressure altitude is available, RAIM is active, RAIM Mode is "Approach", and the Position Dilution of Precision is 1.6.

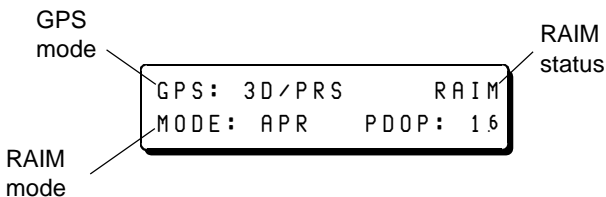

An explanation of the GPS status codes follows.

3D/BARO

The GPS is operating in 3D, external baro altitude input is available.

3D/PRS

The GPS is operating in 3D, external pressure altitude input is available.

3D

The GPS is operating in 3D, no external altitude source is available

2D+BARO

The GPS is operating in 2D using external baro altitude in the position solution.

2D+PRS

The GPS is operating in 2D using external pressure altitude in the position solution.

2D+HELD

The GPS is operating in 2D using the last known altitude in the position solution.

2D+MANL

The GPS is operating in 2D using pilot entered altitude in the position solution.

RAIM status will display:

RAIM

Receiver Autonomous Integrity Monitor is active.

NO RAIM

Receiver Autonomous Integrity Monitor can not provide the required integrity for phase of flight; use of GPS for navigation is still approved, but must be cross-checked with VOR, DME, etc.

RAIM/B

Receiver Autonomous Integrity Monitor is active and using automatic altitude aiding.

TRIMBLE 2101 Approach Plus

RAIM mode will display:

TERM

RAIM to terminal limits of TSO C-129.

APR



RAIM to approach limits of TSO C-129

PDOP varies according to the positional relationship of the satellite in view.

8.3.2 Estimated Accuracy

The Navigator computes an estimate of the worst case position error based on the accuracy of the signals and the geometry of the GPS Satellites. This estimate is displayed on the Estimated Accuracy page.

To display the Estimated Accuracy page:

- Press  to access the Sensor Status mode.
- Rotate the  knob counterclockwise.



ESITMATED ACCURACY:
GPS: 0.02 M

8.3.3 GPS Satellites Tracked Display

- Press **AUX** to access the Sensor Status mode.
- Rotate the  knob clockwise.

The GPS Satellites Tracked page displays the identification numbers of all the Space Vehicles (SVs) being tracked by the Navigator.

The GPS Satellites Tracked page below indicates that the GPS receiver is currently tracking nine satellites. The satellites being tracked are numbers 1, 9, 12, 15, 21, 23, 25, 28, and 31. The Trimble 2101 Approach GPS Navigator tracks all satellites in view.

```
GPS TRACK  9: 31 28
  1  9 12 15 21 23 25
```

A flashing number on the GPS Track page indicates that the associated satellite is being tracked but not used in the position solution due to poor signal strength, bad geometry, manual deselection, or classification of satellite as unhealthy.

8.3.4 GPS Satellite Status Display

The GPS Satellite Status page displays elevation, azimuth, and signal level for each satellite.

To access the GPS Satellite Status Display:

- Press **AUX** to access the Sensor Status mode.
- Rotate the  knob clockwise.

The GPS Satellite Status page below indicates that satellite (SV for Space Vehicle) number 3 is being received with a signal to noise ratio of 10.0; it is currently at an elevation of 29° above the horizon and an azimuth of 248° true.

```
GPS SV: 03  SIG 10.0
  ELV 029°  AZM 248°
```

TRIMBLE 2101 Approach Plus





If a negative elevation appears in this page, it is an indicator that the satellite is below the horizon and not available for use.

To access information on other satellites, rotate the  knob. You may view the status of all satellites whether or not they are currently being tracked.

8.3.4.1 Satellite Database





You may prohibit the GPS receiver from using any satellite in the constellation by disabling that SV from the Satellite Status Page. You should only disable a satellite due to a NOTAM about that satellite.

To disable a satellite:

- Press  to access the Sensor Status mode.
- Rotate the  knob to view the desired satellite.
- Press .
- Rotate the  knob to disable the SV.
- Press .

```
GPS SV: 03 DISABLED
ELV 029° AZM 248°
```

To enable a satellite previously disabled:

- Press  to access the Sensor Status mode.
- Rotate the  to view the desired satellite.
- Press .
 - Rotate the  knob until the ENABLE or SIG is displayed.
- Press .

When the Navigator is turned off then back on, all manually disabled satellites are re-enabled.

8.3.5 GPS Sensor Reset

The Sensor reset causes the GPS receiver to go through its power-on and satellite acquisition sequence as if the unit had been turned off and on.

- Press **AUX** to access the Sensor Status mode.
- Rotate the  knob clockwise to display the GPS Sensor Reset page.





RESET GPS SENSOR?
(ENT)

- Press **ENT**.
- Press **AUX** to confirm reset.

TRIMBLE 2101 Approach Plus

8.3.6 GPS Satellite Availability

The availability page provides coverage predictions for the current location at any date or time.

- Press  to access the Sensor Status mode.
- Rotate the  knob clockwise to view the display shown below.

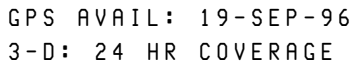

The Satellite Availability page shown below indicates that GPS three dimensional positioning is available 24 hours at the current location on September 19, 1996.



```
GPS AVAIL: 19-SEP-96
3-D: 24 HR COVERAGE
```

If coverage is less than 24 hours, use the  knob to view the next available satellite navigation period.

Enter a specific date or to select between visibility computation for two or three-dimensional positioning:

- Press .
- Use the selector knobs to change the date.
- Press  to compute.

The position used for satellite visibility computations is the last computed fixed position. If the Dead Reckoning (DR) mode has been set, the visibility will be computed for the present DR position.

8.3.7 Approach RAIM Availability

The Approach RAIM Available page provides RAIM predictions for your destination airport ± 15 minutes of your ETE, through the flight plan.



The Approach RAIM Available page also provides RAIM prediction for any Airport and Time entered by the User. To access the function:

- Press **AUX** to access the Sensor Status mode.
- Rotate the  knob clockwise to display the Approach RAIM Availability page.

```
APR RAIM AVAILABLE:  
AUSA 17:37L  $\pm 15$  MIN
```

When an Approach is active, or your flight plan ends with an airport, the associated Airport will automatically be displayed along with the time of arrival through the flight plan.

To determine Approach availability at any Airport:

- Press **ENT**.
- Rotate the  knob to move between the Airport field and the Time field.
- Rotate the  knob to change the Airport ID and/or Time as required.

In the event RAIM is not available at the selected Airport and Time, the following will be displayed:

```
RAIM NOT AVAILABLE:  
SJCA 15:37L
```

8.4 The Configure Mode

The configure mode is used to establish parameters for the following:

- Parallel Track Offset (PTK)
- Dead Reckoning/Demo Mode
- Display Diagnostic

8.4.1 Selecting a Parallel Offset

Parallel track offsets from 99.99 nm left to 99.99 nm right are available from the parallel offset page. A parallel offset changes the displayed cross track error and the CDI, it does not affect the course or distance to the next waypoint. The PTK annunciator is lit when you select an offset other than 0.0 nm.

The Navigator features two Parallel Offset modes:

- Auto Cancel** In this mode, the Navigator automatically cancels the offset when you pass the last waypoint in the flight plan.
- No Cancel** In this mode, the Navigator retains the offset beyond the last waypoint in the flight plan.

When the PTK annunciator is lit, you may view the selected offset from the  key.

Once you have selected an offset, the Navigator maintains that offset through the remainder of the flight plan or until cancelled.

The Navigator cancels the offset after any  operation.

When an approach is enabled, the Navigator cancels the parallel offset and prohibits additional offset selection while the approach is enabled.

To access the Parallel offset feature:

- Press **AUX** to access the Configure mode.
- Rotate the  knob to display the Parallel Offset page.



The display above indicates a parallel offset of 3 nautical miles, an offset direction of Right and Auto Cancel mode.

To select a Parallel Offset:

- Press **ENT**. The Navigator displays the last selected offset value, direction and mode.
- Use the selector knobs to choose the offset value, direction and mode.
- Press **ENT**. The PTK annunciator lights.

TRIMBLE 2101 Approach Plus

8.4.3 The Dead Reckoning Display - Demo Mode

Use the Dead Reckoning Demo mode to simulate the Navigator in-flight operation while on the ground. In this mode, you enter ground speed and ground track under the NAV key to simulate flight. This mode is not available when the Navigator is receiving enough satellite signals to navigate. In order to use this mode, you must have the aircraft hangered, the antenna covered or deselect all satellites.

To select DEMO operation:

- Press **AUX** to access the Configure mode.
- Rotate the  knob to display the Dead Reckoning page.

When the demo mode is available, the Navigator displays:

```
DEAD RECKONING:  ON
(D E M O M O D E )  ( E N T )
```

When the demo mode is not available because the Navigator is receiving enough satellites to navigate, it displays:



```
DEAD RECKONING:  OFF
```

To select a starting position for your demonstration flight:



- Press **ENT**.
- Use the standard method of selecting a waypoint from the WPT or APT/VOR mode.
- Press **AUX**.

Activate a flight plan to fly.

To simulate flight, enter a ground speed and track:

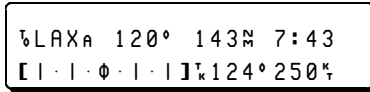
- Press  to access the Primary NAV Mode display.
- Press .



- Rotate the  knob to move among the editable fields.
- Rotate the  knob to set the ground track and ground speed values.
- Press .

The entry is now complete and the Dead Reckoning/Demo mode is enabled. You may now use the Demo mode to demonstrate the Navigator features.

Update ground speed and track as desired. At every track change, the Navigator will set track to an appropriate intercept value for the new leg. Change track as you like.

Upon reaching the last waypoint in the flight plan, the Navigator will set ground speed to zero.



The Navigator will not illuminate the approach light in the demo mode. Since RAIM is not available, the Navigator behaves accordingly; at the FAF-MAP track change, the HLD light illuminates, indicating that the Navigator will not automatically sequence at the MAP and the APR light does not illuminate.

TRIMBLE 2101 Approach Plus

8.4.4 The Display Diagnostic Page

Use the Display Diagnostic page to check the display and internal annunciator lights.

To access the Display Diagnostic page:

- Press  to access the Configure mode.
- Rotate the  knob to display the Display Diagnostic page.

The “DISPLAY DIAGNOSTIC” message appears briefly. Then the display changes to dashed horizontal lines. Horizontal lines move through all the fields of both lines of the display. The annunciator lights and push-button keys light in sequence. This pattern continues until you turn the selector knobs or press a key. This display allows a visual check to determine if these features are operating properly.

8.5 User Setup Mode

The User Setup mode, if available, allows you to configure the Navigator to your specific needs. You can choose the database search regions, set the AIRWATCH feature to your specification, secure the Navigator, and save or load the Navigator’s configuration. Instructions for the User Setup mode are in Appendix C.

Chapter 9

The Message Key

The Navigator keeps you apprised of all critical information that relates to the current flight. A flashing MSG annunciator light prompts you to view messages. If the Navigator is wired to your audio panel, you also will hear a beeping tone anytime the MSG annunciator is flashing.

This Chapter covers:

- Understanding flashing and non-flashing indicators
- Display messages
- Message priority
- Interpreting System, Parallel Track, and Advisory messages

TRIMBLE 2101 Approach Plus

9.1 Accessing Messages

The Navigator uses an internal and an external MSG annunciator light to communicate special messages to the user.

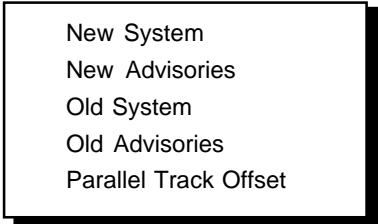

New messages are indicated by flashing internal and external MSG annunciators. If there are multiple messages that have not been viewed yet, the light continues to flash until all messages have been viewed. Old messages that are still relevant cause the internal message indicators to remain on (steady rather than flashing) as a reminder that the condition that caused the message is still unresolved. The external MSG annunciator flashes only when there is an unread message; otherwise, it is off.

Messages are displayed in order of priority. New System messages have highest priority:



- New System
- New Advisories
- Old System
- Old Advisories
- Parallel Track Offset



If a message is waiting, the **MSG** annunciator is illuminated. To access messages:

- Press the  key.
- The first message is displayed and the  key is illuminated.

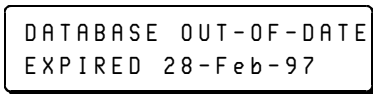
The message below is an Advisory message indicating that the installed Jeppesen NavData Card is out of date.



```
DATABASE OUT-OF-DATE
EXPIRED 28-FEB-97
```

The first message appears on the screen. If more than one message is waiting, the  key will remain lit. If this is the case, continue to press the  key and read through all waiting messages.

When the  key is no longer lit, all messages have been viewed and the Navigator is returned to the previous mode in use.

If a message continues to be relevant, the internal MSG annunciator remains lit; the external annunciator is off. The message can be viewed again by pressing the  key.

TRIMBLE 2101 Approach Plus

9.2 System Messages

New System messages are given highest priority and are always displayed first.

The following is a list of system messages and an explanation for each.

Message	Condition	Pilot Action
DEAD RECKONING ENTER GS & TRACK	The receiver is not doing any position fixes. This message is always issued when the Navigator is first turned on. It will extinguish when the Navigator has locked on to enough satellites to navigate.	Enter GS and Track from NAV to operate in DR.
GPS POSITION RESTORED	The Navigator is no longer in Dead Reckoning mode.	Normal system operation has been restored. Entry of Ground Speed and Track no longer required.
RAIM UNAVAILABLE	The Navigator Plus is unable to perform RAIM due to insufficient satellites.	Cross check position with other approved navigation sources.
RAIM RESTORED	The Navigator Plus is now receiving sufficient satellite signals to perform RAIM.	Cross checking with other sources is not required.
GPS: RECEIVER FAIL BATTERY BACK-UP FAIL	The internal battery has failed. As a result, all stored waypoints and flight plans were erased. All setup data is lost.	System is inop.
GPS: RECEIVER FAIL ALIGNMENT ERROR CH#1	BITE has detected a GPS receiver failure.	Cross check position with other approved navigation sources.
GPS: RECEIVER FAIL ALIGNMENT ERROR CH#2	BITE has detected a GPS receiver failure.	Cross check position with other approved navigation sources.
GPS: RECEIVER FAIL SIGNAL PROCESSOR ERR	BITE has detected a GPS receiver failure.	Cross check position with other approved navigation sources.
GPS: RECEIVER FAIL	BITE has detected a GPS receiver failure.	Cross check position with other approved navigation sources.

Message	Condition	Pilot Action
GPS: RECEIVER FAIL I/O TIMEOUT	BITE has detected a GPS receiver failure.	Cross check position with other approved navigation sources.
GPS DISABLED BY USER SEE INSTALL: SERIAL	The Navigator has been left in a test mode. Contact your maintenance facility	System is inop.
DATABASE MISSING	or the factory. The database card is missing or is not installed properly.	1. Turn unit off. 2. Install database card. 3. Restart unit.
DATABASE CARD TYPE NOT VALID	The installed NavData card is invalid. Verify the data card is an approach card.	1. Turn unit off. 2. Install correct database card for 2101 I/O Plus. 3. Restart unit.
EXTERNALALTIMETER LOST COMMUNICATION	The communication link from the altitude serializer	1. Turn unit off. 2. Install correct database card for 2101 I/O Plus. 3. Restart unit.
EXTERNALALTIMETER IS IN ERROR	(encoder) has failed. Bad data was received from the altitude serializer (encoder). This message may appear due to warm-up time required by	Check altitude input
EXTERNALALTIMETER DATA OK	external altimeter source. External altimeter source	None
GPS: ANTENNA FAULT	now operating normally. BITE has detected a GPS	Cross check position with other approved navigation sources.
LOW VOLTAGE: INPUT VOLTAGE: 10.6V	antenna failure. The input voltage is below 11V for a 14V aircraft or in a range between 18V and 22V for a 28V aircraft.	Check aircraft generator/alternator.
WAYPOINT RECORD NOT FOUND IN DATABASE	The selected waypoint or waypoint in the flight plan is not in the currently installed database.	Replace or delete the waypoint.
CROSS TRACK ERROR GREATER THAN 4 ^{nm}	The difference between the current track and the desired track is greater than four nautical miles. This message is off unless enabled during installation.	Maneuver the aircraft to intercept selected track.
MANUAL MAGNETIC VARIATION IN USE	System was left in test mode. Manually entered magnetic variation is use instead of computed magnetic variation.	System is inop.

TRIMBLE 2101 Approach Plus

Message	Condition	Pilot Action
AIR DATA COMPUTER: FUEL FLOW SENSR FAIL	The fuel flow sensor to the air data computer is not working properly.	Check fuel flow input source.
FAULT ON EXTERNAL APR ANNUNCIATOR	BITE has detected a short circuit.	None.
FAULT ON EXTERNAL HLD ANNUNCIATOR	BITE has detected a short circuit.	None.
FAULT ON EXTERNAL MSG ANNUNCIATOR	BITE has detected a short circuit.	None.
FAULT ON EXTERNAL WPT ANNUNCIATOR	BITE has detected a short circuit.	None.
INTERNAL CDI: $\pm 5.0 \text{M}$ EXTERNAL CDI: $\pm 5.0 \text{M}$	Indicates the current setting for the internal and external CDI. This message is always available.	None
RAIM ERROR	RAIM has detected an error in the GPS position solution.	If flying an approach, execute a Missed Approach. Cross check position with other approved navigation sources.
POSITION IS OUTSIDE OF CURRENT GRID	Operator has selected a grid reference system other than WGS84 and the viewed position is outside the selected system.	None.

If one of the following messages is displayed, record the number (xx) displayed and contact the factory.

Message	Condition	Pilot Action
PRCSSR BUS ERROR xx CONTACT FACTORY	BITE has detected a system computer failure.	System is inop.
ADDRESS ERROR xx CONTACT FACTORY	BITE has detected a system computer failure.	System is inop.
ILLGL INSTRUCTION xx CONTACT FACTORY	BITE has detected a system computer failure.	System is inop.
ZERO DIVIDE xx CONTACT FACTORY	BITE has detected a system computer failure.	System is inop.

Message	Condition	Pilot Action
CHECK REGISTER xx CONTACT FACTOR	BITE has detected a system computer failure.	System is inop.
PRIVILEGE VIOLTN xx CONTACT FACTORY	BITE has detected a system computer failure.	System is inop.
ILLEGAL INTERRUPT xx CONTACT FACTORY	BITE has detected a system computer failure.	System is inop.
TRAP OVERFLOW xx CONTACT FACTORY	BITE has detected a system computer failure.	System is inop.
STACK FULL ERROR xx CONTACT FACTORY	BITE has detected a system computer failure.	System is inop.
MESSAGE ROUTINE xxxxx NOT FOUND	BITE has detected a system computer failure.	System is inop.
ERROR IN MSG FIND MESSAGE x NOT FOUND	BITE has detected a system computer failure.	System is inop.

The following system message will be displayed only with software versions 240B and later.

Message	Condition	Pilot Action
GPS CONFIG INVALID IFR NOT ALLOWED	The software configuration of the GPS does not match the system definition	System is inop.

9.3 Advisory Messages

Advisory messages are shown after any existing system messages. The following are examples of Advisory messages and an explanation for each.

9.3.1 Database Advisory Messages

Message	Condition	Pilot Action
DATABASE OUT-OF-DATE EXPIRED 27 FEB 97	The database card has expired.	Verify navigation/route data using current information.

TRIMBLE 2101 Approach Plus

9.3.2 Flight Plan Advisory Messages

Message	Condition	Pilot Action
TURN TO 320° in 0:XX	The Turn Anticipation display will continuously update to keep the pilot apprised of the approaching turn. Once this message is displayed, the MSG annunciator light remains lit until display timer reaches zero. This message is OFF. See Section 8.	None.
TURN TO INTERCEPT NEW COURSE 320°	This message appears at each track change. It displays the desired track of the new leg.	Set HSI/CDI to displayed course.
EXECUTE HOLD PATTERN TO INBOUND CRS XXX°	This message appears when the next leg is a holding pattern course reversal.	Set HSI/CDI to displayed course. Maneuver aircraft to intercept the inbound course to the holding fix. Press NAV or MSG to acknowledge.
EXECUTE P-TURN TURN TO XXX°	This message appears when the next leg is a procedure turn. The suggested heading is the p-turn outbound heading.	Manually execute the p-turn according to published procedures. Press NAV or MSG to acknowledge.
ARRIVAL AT PAO _A WITHIN 59 SECONDS	When approaching final destination, the pilot receives a countdown advisory. This message is OFF. See Section 8.	None.
DESTINATION WAYPOINT IS LAT 0.0 LON 0.0	The flight plan includes a waypoint that does not exist in the current database card or in User waypoint memory. Usually due to the waypoint being deleted or renamed in the current database update.	Replace or delete waypoint from the flight plan.
DUPLICATE WAYPOINTS IN FLIGHT PLAN	The flight plan contains waypoint(s) that are identical to waypoints in the procedure (SID, STAR, APPROACH) just added.	1) Review flight plan. 2) Edit as necessary.

9.3.2 Flight Plan Advisory Messages (cont.)

Message	Condition	Pilot Action
MAX PLAN # REACHED NO MORE ADDITIONS	40 flight plans have been stored and the FPL memory is full.	Delete a stored flight plan to enter another.
NO ROOM TO ADD TERMINAL PROCEDURE	40 flight plans have been stored and FPL memory is full.	Delete a stored flight plan to enter another.
MAXIMUM # REACHED• NO MORE ADDITIONS•	250 User waypoints have been stored and User waypoint memory is full.	Delete a stored User Waypoint to enter another.

9.3.3 Approach Advisory Messages

Message	Condition	Pilot Action
APPROACH ENABLE? ENT BARO: 29.92	Enter current baro setting and enable the approach.	1) Use knob to set the baro. 2) Press ENT to enable the approach.

9.3.4 Parallel Track Advisory Messages

Message	Condition	Pilot Action
PARALLELOFFSET CANCELLED	Parallel offset was cancelled. Any direct-to will cancel the offset, as will enabling an approach.	None.
PTK OFF AUTO CANCEL 10.00 \overline{M} RIGHT	Displayed when a parallel offset is selected. In this example, parallel offset has been set for 10 nm right and the Auto Cancel option has been selected. The parallel track will be cancelled, when an approach is enabled, when the course-to-destination differs from the desired track by 45° or more, or when the "one minute to arrival" message is displayed.	None.

TRIMBLE 2101 Approach Plus

9.3.4 Parallel Track Advisory Messages (cont)

Message	Condition	Pilot Action
PTK OFF NO CANCEL 10.00 LEFT	In this example, parallel offset has been set for 10 nm left and the No Cancel option has been selected. The parallel track will not be cancelled upon arrival at the destination.	None.
PTK OFF AUTO CANCEL APPROACH ENABLED	Selected offset was cancelled when the approach was enabled. Parallel offset cannot be set while an approach is enabled.	None.

9.3.5 Fuel Management Advisory Messages

When the fuel on board is not zero, the following messages may appear.

Message	Condition	Pilot Action
CAUTION: USING FUEL RESERVE TO POA _A	If the amount of time remaining at current fuel flow rate is less than the time to reach the destination plus the amount of time you selected on the Minimum Fuel page under the key (45 minutes is the default), this advisory will appear. This message is deleted once	Verify fuel remaining.
CAUTION: EXHAUSTED FUEL WITHIN 0:29	The calculated fuel required to reach the destination on the Fuel Management page is more than the fuel remaining on the Fuel Remaining page. This message is deleted once viewed.	Verify fuel remaining.
CAUTION: NOT ENOUGH FUEL TO REACH PAO _A	The flight time remaining on the Fuel Remaining page is less than 30 minutes (the timing on this message can be edited using the key). This message is deleted once viewed.	Verify fuel remaining.

9.3.6 AIRWATCH™ Advisory Messages

When AIRWATCH™ is enabled, the Navigator displays advisories regarding controlled and restricted airspace. A message to contact the appropriate agency is wrapped on the second line of the display. The frequency on which to contact the agency is also shown. Examples are shown below.

Message	Condition	Pilot Action
INSIDE SAN FRANCISCO ClsB INSIDE CONTACT BAY APP ON INSIDE BAY APP ON 120.9	You are within the San Francisco Class B airspace. Contact Bay approach on frequency 120.9.	Contact ATC
CLOSE R 2533 RESTRICTED	You are within 10 nm of the R2533 restricted airspace. There is no contact agency or frequency.	None.
IN PATH SANTA BARBARA ClsC	You will enter the Santa Barbara Class C airspace in approximately 10 minutes on present track and speed.	Verify flight plan.
IN FUTURE TRACK SANTA BARBARA ClsC	You will enter the Santa Barbara Class C airspace in approximately 10 minutes on present track and speed.	Verify flight plan.

9.3.7 Other Advisory Messages

The following advisory message will be displayed only with software versions 240B and later.

Message	Condition	Pilot Action
CLEAR BATTERY BACKED MEMORY SUCCESSFUL	The unit has been reset using the 3-finger reset and the battery backed memory has been successfully cleared.	None.

TRIMBLE 2101 Approach Plus

This page intentionally left blank.

Appendix **A**

Reference

TRIMBLE 2101 Approach Plus

A.1 State and Province Codes

The following codes are used to identify States and Provinces in the Jeppesen North American NavData database listed in alphabetical order by identifier.

State or Province	Code	State or Province	Code
ALBERTA	AB	JAMAICA	JAM
ANGUILLA	AIA	JOHNSTON IS	JTN
ALABAMA	AL	ST KITTS	KNA
ALASKA	AK	KANSAS	KS
ARUBA	ANT	KENTUCKY	KY
ARKANSAS	AR	LOUISIANA	LA
ANTIGUA	ATG	ST LUCIA	LCA
ARIZONA	AZ	MASSACHUSETTS	MA
BRITISHCOLUMBIA	BC	MANITOBA	MB
BAHAMAS	BHS	MARYLAND	MD
BELIZE	BLZ	MAINE	ME
BERMUDA	BMU	MEXICO	MEX
BARBADOS	BRB	MICHIGAN	MI
CALIFORNIA	CA	MINNESOTA	MN
CANADA	CAN	MISSOURI	MO
COLORADO	CO	MISSISSIPPI	MS
COLOMBIA	COL	MONTERRAT IS	MSR
COSTARICA	CRI	MONTANA	MT
CONNECTICUT	CT	MARTINIQUE	MTQ
CUBA	CUB	NEW BRUNSWICK	NB
CAYMAN ISLANDS	CYN	NORTH CAROLINA	NC
DISTRICT OF COLUMBIA	DC	NORTH DAKOTA	ND
DELAWARE	DE	NEBRASKA	NE
DOMINICA	DMA	NEWFOUNDLAND	NF
DOMINICAN REPUBLIC	DOM	NEW HAMPSHIRE	NH
FLORIDA	FL	NICARAGUA	NIC
GEORGIA	GA	NEW JERSEY	NJ
GUADELOUPE	GLP	NEW MEXICO	NM
GRENADA	GRD	NOVA SCOTIA	NS
GUATEMALA	GTM	NEVADA	NV
HAWAII	H	NORTHWEST TERRITORIES	NW
HONDURAS	HND	NEW YORK	NY
HAITI	HTI	OHIO	OH
IOWA	IA	OKLAHOMA	OK
IDAHO	ID	ONTARIO	ON
ILLINOIS	IL	OREGON	OR
INDIANA	IN	PENNSYLVANIA	PA

State or Province	Code
PANAMA	PAN
PRINCE EDWARD IS	PE
QUEBEC	PQ
PUERTO RICO	PRI
RHODE ISLAND	RI
RUSSIA	RUS
SOUTH CAROLINA	SC
SOUTH DAKOTA	SD
EL SALVADOR	SLV
SASKATCHEWAN	SK
MIQUELON IS	SPM
CAICOS IS	TCA
TURKS IS	TCA
TENNESSEE	TN
TOBAGO	TTO
TEXAS	TX
UNITED STATES	USA
UTAH	UT
VIRGINIA	VA
ST VINCENT	VCA
BRITISH VIRGIN IS	VGB
VIRGIN IS	VIR
VERMONT	VT
WASHINGTON	WA
WISCONSIN	WI
WEST VIRGINIA	WV
WYOMING	WY
YUKON TERRITORY	YK

TRIMBLE 2101 Approach Plus

A.2 Country Codes

The following codes are used to identify Countries in the Jeppesen International NavData database.

Country	Code	Country	Code
AFGANISTAN	AFG	ALGERIA	DZA
ANGOLA	AGO	ECUADOR	ECU
ALBANIA	ALB	EGYPT	EGY
UNTD ARAB EMIRATES	ARE	CANARY IS	ESP
ARGENTINA	ARG	MELILLA	ESP
ARMENIA	ARM	SPAIN	ESP
AMERICAN SAMOA	ASM	ESTONIA	EST
ANTARCTICA	AUS	ETHIOPIA	ETH
AUSTRALIA	AUS	FINLAND	FIN
AUSTRIA	AUT	FIJI IS	FJI
AZERBAIJAN	AZE	FALKLAND IS	FLK
BURUNDI	BDI	FRANCE	FRA
BELGIUM	BEL	FAERO IS	FRO
BENIN	BEN	CAROLINE IS	FSM
BURKINA FASO	BFA	MICRONESIA	FSM
BANGLADESH	BGD	PALAU	FSM
BULGARIA	BGR	GABON	GAB
BAHRAIN	BHR	UNITED KINGDOM	GBR
BELORUSSIA	BLR	GEORGIA	GEO
BOLIVIA	BOL	GHANA	GHA
BRAZIL	BRA	GIBRALTAR	GIB
BRUNEI	BRN	GUINEA REP	GIN
BHUTAN	BTN	GAMBIA	GMB
BOTSWANA	BWA	GUINEA-BISSAU	GNB
CENTRAL AFRICAN REP	CAF	EQUATORIAL GUINEA	GNQ
SWITZERLAND	CHE	GREECE	GRC
CHILE	CHL	GREENLAND	GRL
CHINA, PR OF	CHN	FRENCH GUIANA	GUF
IVORY COAST	CIV	GUAM	GUM
CAMEROON	CMR	MARIANA IS	GUM
CONGO	COG	HAWAII	HI
COOK IS	COK	HONG KONG	HKG
COLOMBIA	COL	CROATIA	HRV
COMOROS	COM	HUNGARY	HUN
CAPE VERDE	CPV	INDONESIA	IDN
CYPRUS	CYP	INDIA	IND
CZECH	CZE	CHAGOS ARCH	IOT
GERMANY	DEU	IRELAND	IRL
DJIBOUTI	DJI	IRAN	IRN
DENMARK	DNK	IRAQ	IRQ
FAROE IS	DNK	ICELAND	ISL

Country Codes

Country	Code	Country	Code
ISRAEL	ISR	NAURU	NRU
ITALY	ITA	NEW ZEALAND	NZL
JORDAN	JOR	OMAN	OMN
JAPAN	JPN	PAKISTAN	PAK
JOHNSTON I	JTN	PERU	PER
KAZAKHSTAN	KAZ	PHILLIPINES	PHL
KENYA	KEN	PAPUA NEW GUINEA	PNG
KYRGYZSTAN	KGZ	POLAND	POL
KAMPUCHEA	KHM	KOREA, DPR OF	PRK
KIRIBATI	KIR	PORTUGAL	PRT
KOREA	KOR	PARAGUAY	PRY
KUWAIT	KWT	FRENCH POLYNESIA	PYF
LAOS	LAO	QATAR	QAT
LEBANON	LBN	REUNION	REU
LIBERIA	LBR	ROMANIA	ROM
LIBYA, SPA JAMAH.	LYB	RUSSIA	RUS
SRI LANKA	LKA	RWANDA	RWA
LESOTHO	LSO	SAUDI ARABIA	SAU
LITHUANIA	LTU	SUDAN	SDN
LUXEMBOURG	LUX	SENEGAL	SEN
LATVIA	LVA	SINGAPORE	SGP
MOROCCO	MAR	ASCENSION	SHN
MOLDOVA	MDA	ST HELENA	SHN
MALDIVES	MDV	SOLOMON IS	SLB
MARSHALL IS	MHL	SIERRA LEONE	SLE
MIDWAY I	MID	SOMALIA	SOM
MALI	MLI	SAO TOME & PRINCIPE	STP
MALTA	MLT	SURINAME	SUR
UNION OF MYANMAR	MMR	SLOVAKIA	SVK
MONGOLIA	MNG	SLOVENIA	SVN
MARIANA IS	MNP	SWAZILAND	SWZ
MOZAMBIQUE	MOZ	SWEDEN	SWE
MAURITANIA	MRT	SEYCHELLES	SYC
MAURITIUS	MUS	SYRIA	SYR
MALAWI	MWI	CHAD	TCD
MALAYSIA	MYS	TOGO	TGO
MAYOTTE	MYT	THAILAND	THA
NEW CALEDONIA	NCL	TAJIKISTAN	TJK
NIGER	NER	TURKMENISTAN	TKM
NIGERIA	NGA	TONGA	TON
NIUE	NIU	TUNISIA	TUN
NETHERLANDS	NLD	TURKEY	TUR
NORWAY	NOR	TUVALU	TUV
NEPAL	NPL	TAIWAN	TWN
		TANZANIA	TZA

TRIMBLE 2101 Approach Plus

Country Codes

Country	Code
UGANDA	UGA
UKRAINE	UKR
URUGUAY	URY
UNITED STATES	USA
UZBEKISTAN	UZB
VENEZUELA	VEN
VIETNAM	VNM
VANUATU	VUT
FUTUNA IS	WLF
WESTERN SAMOA	WSM
ARMENIA	XJA
KYRGYZSTAN	XJI
AZERBAIJAN	XJJ
KAZAKHSTAN	XJK
MOLDOVA	XJO
RUSSIA	XJR
TAJIKISTAN	XJT
WAKE I	XJW
YEMEN ARAB REP	YEM
YUGOSLAVIA	YUG
BOPHUTHATSWANA	ZAF
CISKEI	ZAF
NAMIBIA	ZAF
SOUTH AFRICAN REP	ZAF
SOUTHWEST AFRICA	ZAF
TRANSKEI	ZAF
VENDA	ZAF
ZAIRE	ZAR
ZAMBIA	ZMB
ZIMBABWE	ZWE

TRIMBLE 2101 Approach Plus

A.3.2 Standard ARINC Geographic Coverages

Refer to Figure A-2 for the standard ARINC geographic coverages.

Figure A-2: Standard ARINC Geographic Coverages

A.4 GPS Status Messages

GPS Status Messages include the following:

- GPS: ANTENNA FAULT
The GPS antenna is not connected or is not operating properly.
- GPS: NO GPS TIME
Satellite signal levels are too low to receive.
- GPS: NO SV AVAILABLE
No satellites are in view at this time.
- GPS: NO USABLE SVs
Tracking at least one SV. Time is being obtained.
- GPS: NOT AVAILABLE
GPS sensor has failed.
- GPS: ONLY n USABLE SV
Tracking 1 or 2 SVs. Need 3 for position fix.
- GPS: PDOP TOO HIGH
Tracking at least three SVs, but geometry is bad.
- GPS: RECEIVER FAIL
The GPS receiver is not functioning correctly and requires service.
- GPS: USING n SV 2-D
Tracking 3 or more SVs. Computing a 2-D position.
- GPS: USING 4 SV 3-D
Tracking 4 or more SVs. Computing a 3-D position.

A.5 Changing NavData Cards During Flight

The Domestic and International NavData cards have few overlapping waypoints (except Hawaii). If your plans call for crossing NavData card boundaries, we recommend making two separate flight plans, one for each card. Fly the flight plan of the card currently being used. Change cards when it becomes necessary. Then, activate the second flight plan to continue on the next leg.

Perform the following steps to change the NavData card:

1. Remove the NavData card currently being used. The current active FPL is cancelled. The current TO waypoint is preserved.
2. Insert the desired NavData card.
3. Select a FPL for the inserted card.

A.6 Local Geodetic Reference Datums

<u>Datum</u>	<u>Locality</u>
Adindan	Ethiopia, Mali, Senegal, Sudan
AFG	Somalia
Ain El Abd 1970	Bahrain Is.
Alaska (NAD-27)	Alaska
Alaska/Canada NAD-27	Alaska/Canada
Anna 1 Astro 1965	Cocos Is.
ARC-1950 mean	Botswana, Lesotho, Malawi, Zaire Swaziland, Zimbabwe
ARC-1960 mean	Kenya, Tanzania
Ascension Island '58	Ascension Is.
Astro Beacon "E"	Iwo Jima Is.
Astro B4 Sor. Atoll	Tern Is.
Astro Pos 71/4	S. Helena Is.
Astronomic Stn. '52	Marcus Is.
Australian Geodetic 1952	Australia, Tasmania
Australian Geodetic 1984	Australia, Tasmania
Bahamas (NAD-27)	Bahamas except San Salvador
Bellevue (IGN)	Efate & Erromango Is.
Bermuda 1957	Bermuda Is.
Bogota Observatory	Colombia
Bukit Rimpah	Indonesia
Camp Area Astro	Antarctica
Campo Inchauspe	Argentina
Canada Mean (NAD27)	Canada incl. Newfoundland
Canal Zone (NAD27)	Panama Canal Zone
Canton Island 1966	Phoenix Is.
Cape	South Africa
Cape Canaveral mean	Florida & Bahama Is.
Carribean (NAD27)	Barbados, Caicos Is., Cuba, Dominican Rep., Grand Cayman, Jamaica, Leeward Is., Turks Is.
Carthage	Tunisia
Central America (NAD27)	Belize, Costa Rica, El Salvador, Guatemala
Chatham 1971	Chatham Is., NZ
Chua Astro	Paraguay
Corrego Alegre (Provisional)	Brazil
Cuba (NAD27)	Cuba

TRIMBLE 2101 Approach Plus

Cyprus	Isle of Cyprus
Djakarat (Batavia)	Sumatra Is.
DOS 1968	Gizo Is., Solomon Is.
Easter Island 1967	Easter Island
Egypt	Egypt
European 1950 mean	Austria, Denmark, Finland, France, Germany, Gibraltar, Greece, Italy, Netherlands, Norway, Portugal, Spain, Switzerland
European 1950	Western Europe
European 1979 mean	Austria, Finland, Netherlands, Norway, Spain, Sweden, Switzerland
Finish Nautical Chart	Finland
Gandajika Base	Republic of Maldives
Geodetic Datum '49	New Zealand
Ghana	Ghana
Ordnance Survey of Great Britain '36	England, Isle of Man, Scotland, Shetland Isles, Wales
Greenland (NAD27)	Greenland
Guam 1963	Guam Is.
Gunung Segara	S.E. Borneo
Gunung Serindung 1962	S.W. Borneo
GUX 1 Astro	Guadalcanal Is.
Herat North	Afghanistan
Hjorsej 1955	Iceland
Hong Kong 1963	Hong Kong
Hu-Tzu-Shan	Taiwan
Indian	Bangladesh, India, Nepal
Iran	Iran
Ireland 1965	Ireland
ISTS 073 Astro '69	Diego Garcia
Johnston Island '61	Johnston Is.
Kandawala	Sri Lanka
Kerguelen Island	Kerguelen Is.
Kertau '48	West Malaysia, Singapore
La Reunion	Mascarene Is.
L.C. 5 Astro	Cayman Brac Is.
Liberia 1964	Liberia
Luzon	Philippines except Mindanao
Mahe 1971	Mahe Is., Seychelles
Massawa	Eritrea
Merchich	Morocco
Mexico (NAD27)	Mexico

Midway Astro '61	Midway Is.
Mindanao	Mindanao Is.
Minna	Nigeria
Montjong Lowe	Celebes Is.
Nahrwan	Saudia Arabia
Namibia	Namibia
Naparima, BWI	Trinidad, Tobago
North America 1927 mean	CONUS
North America '83	Alaska, Canada, Central America, CONUS, Mexico
Observatorio 1966	Corvo, Santa Cruz, Flores Is.
Old Egyptian	Egypt
Old Hawaiian mean	Hwaiian Is.
Old Hawaiian, Maui	Maui
Old Hawaiian, Oahu	Oahu
Old Hawaiian, Kauai	Kauai
Oman	Oman
Pico De Las Nieves	Canary Is.
Pitcairn Astro '67	Pitcairn Is.
Puerto Rico	Puerto Rico, Virgin Is.
Quatar National	Quatar
Qornoq	S. Kalaallit Nunaat
Rome 1940	Sardinia
SAD-69/Brazil	Brazil
Santa Braz	Saint Miguel, Santa Maria Is.
Santo (DOS)	Espiritu Santo Is., New Hebrides
Sapper Hill '43	East Falkland Is.
Schwarzeck	Nambia
Sicily	Sicily
Sierra Leone 1960	Sierra Leone
Provisional South	Bolivia, Chile, Colombia, Ecuador, Guyana, Peru, Venezuela
South American 1969 mean	Argentina, Bolivia Brazil, Chile, Colombia, Ecuador, Guyana, Paraguay, Peru, Venezuela, Trinidad, Tobago
South Asia	Singapore
Provisional South Chilean 1963	South Chile
S.E. Asia (Indian)	Bangladesh, India, Kampuchea, Laos, Nepal, Thailand, Vietnam
Southeast Base	Porto Santo, Maderia Is.
Southwest Base	Azores

TRIMBLE 2101 Approach Plus

Tananarive	Madagascar
Observatory '25	
Thai/Viet (Indian)	Thailand, Vietnam
Timalai 1948	Brunei, E. Malaysia
Tokyo mean	Japan, Korea, Okinawa
Tristan Astro 1968	Tristan da Cunha
Unites Arab	United Arab Emirates
Emirates (Nahrwan)	
Viti Levu 1916	Viti Levu Is.
Voirol	Algeria, Tunisia
Wake-Eniwetok '60	Marshall Is.
WGS-72	Former World
WGS-84	World
Yacare	Uruguay
Zanderij	Surinam

NOTES

NOTES

Appendix **B**

The GPS System: How It Works

GPS (Global Positioning System) is a navigation system based on a constellation of 24 satellites orbiting the earth at very high altitude. This system was established and is maintained by the U.S. Department of Defense. GPS can give three-dimensional position measurements accurate to within 50 feet (15 m).

GPS is based on satellite ranging: calculating a position by measuring the distance to several different satellites. If we know that the distance from satellite A is 11,000 miles, then we must be somewhere on an imaginary sphere centered on the satellite and having a radius of 11,000 miles as shown in Figure B-1. If, at the same time, the distance from satellite B is known to be 12,000 miles, then we must be on the circle where the two spheres intersect, as shown in Figure B-2.

If we also know that we are 13,000 miles from satellite C, our position is further restricted to the two points in space where the three spheres intersect, as shown in Figure B-3. One of these points is usually impossible (for example, far out in space). GPS receivers have various techniques for distinguishing the correct point from the incorrect one. Theoretically, these three measurements are all we need to determine the position of our aircraft.

The basic idea behind measuring the distance to a satellite is the “velocity times travel-time” equation we all learned in school:

$$\text{Distance} = \text{Velocity} \times \text{Time}$$

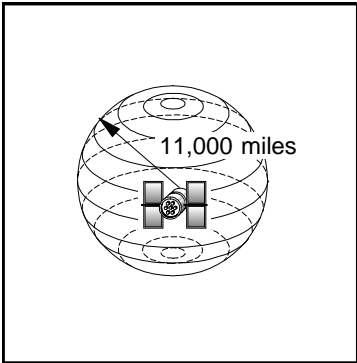

Figure B-1

Figure B-2

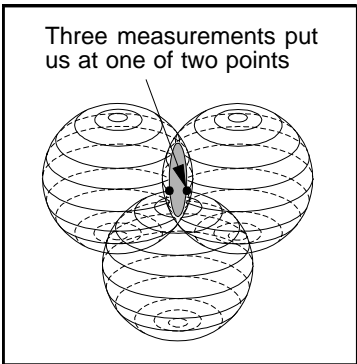
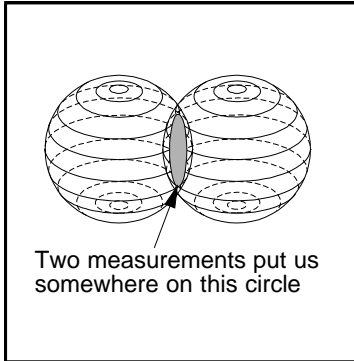

Figure B-3

The GPS system works by calculating how long a radio signal from a satellite takes to reach us, and then calculating the distance to the satellite based on that time. We know the velocity of light (about 186,000 miles per second). So if we can determine exactly when the GPS satellite started sending its radio signal, and exactly when we received it, we can calculate how long the signal took to reach us.

How can the GPS receiver determine exactly when the signal left the satellite? The satellites and receivers are very precisely synchronized to generate the same pattern of radio signals at exactly the same time. This pattern, or code, is a complicated string of pulses that appears to be random, but is in fact, carefully determined. Since the code appears to be random, it is often referred to as “pseudo-random code”.

When the GPS receiver receives a satellite code, it measures the time that elapsed between when it generated that code and when it received the same satellite code. Plugging this value into the equation above will give us the distance from our aircraft to the satellite.

Of course, the measurements must be very precise—down to a nanosecond, or one billionth of a second. The satellites achieve this accuracy by means of atomic clocks that are amazingly precise. GPS receivers are equipped with very precise electronic clocks—but not always precise enough. Fortunately, trigonometry says that if three perfect measurements locate a point in three-dimensional space, then four imperfect measurements can eliminate any clock offset (as long as the offset is consistent). So by making an extra satellite range measurement, we can eliminate clock offset.

An example will help explain this. For simplicity (and to eliminate the need for three-dimensional graphics), let's use a two-dimensional example, such as a ship at sea (where altitude is already known). This means that, if our clocks were perfect, we would need only two range measurements to locate ourselves exactly on the surface of the earth. The third range measurement will be our “extra” one.

TRIMBLE 2101 Approach Plus

Consider the example in Figure B-4. Suppose our receiver's clock is consistent, but is 1 second slow. And, let's say that the signal from satellite A takes 4 seconds to reach us, while the signal from satellite B takes 6 seconds. So we really are where the two solid lines intersect.

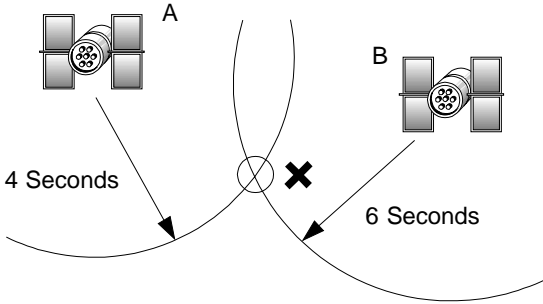

Figure B-4

But, our imperfect receiver would think the signal from satellite A took 5 seconds to reach us, and that from satellite B, 7 seconds. So our receiver thinks we are where the two shaded lines intersect—which could be miles from our actual location.

Now let's add a third measurement to the calculation. The signal from satellite C takes 8 seconds to reach us, and our receiver thinks it's 9. From Figure B-5 we can see that the three solid lines intersect at our true location.

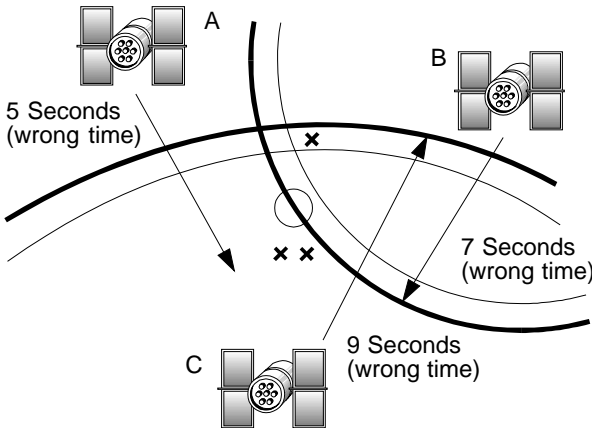

Figure B-5

But, if we add our one-second offset to the drawing, the three shaded lines show three possibilities for our location—the “pseudo ranges” caused by our slow clock.

The GPS receiver, upon receiving this series of points, assumes that its clock is off. It applies algebra to compute where the three points could possibly intersect, and gives this intersection as our true location.

Since an aircraft GPS system operates in three dimensions, it needs four measurements to cancel out any error. This means that it can't determine a truly accurate position unless it has four satellites within range above the horizon. Until all 24 satellites are in place, there may be times when fewer than four satellites are available overhead. During these times, altitude from an encoder or manual input can permit continued navigation at reduced accuracy.

There are some other sources of minor errors in the GPS system. Tiny variations can occur in the altitude, speed, and position of a satellite. These changes are monitored by the Department of Defense, and the corrections are sent back to the satellite, where they are broadcast along with the pseudo codes. Other variations can be caused by ionospheric and atmospheric delays. Another possible source of error is “Geometric Dilution of Precision,” which means that the intersection point of two ranges is slightly less accurate when the satellites are close together. In a typical case, the sum of these errors would amount to no more than 100 feet (30m); in a worst case, no more than 200 feet (70m).

For military purposes, the Department of Defense can also introduce deliberate errors into the system using an operational mode called “selective availability,” or S/A. The stated accuracy with S/A on is as follows:

- Better than 100m, 95% of the time
- Better than 300m, 99% of the time

The other 1% is undetermined, the DOD can set the accuracy reduction much higher!

TRIMBLE 2101 Approach Plus

A sophisticated form of GPS, differential GPS, allows precise measurements down to a centimeter (1" = 2.54 cm). Such ultra-precise measurements are based on at least fifteen minutes of GPS data collection at a stationary location and very precise knowledge of a reference point. This form of GPS is used in surveying and is being tested as a precision landing system.

B.1 GPS Information Center

Precise Worldwide Position, Velocity, and Time

GPS enables land, sea, and airborne users to determine their three-dimensional position, velocity, and time anywhere in the world with unprecedented accuracy. Satellite-based GPS is the most precise radio navigation system available today or in the foreseeable future.

GPS consists of three segments: space, control, and user. The space segment will ultimately contain 21 operational satellites about 10,900 nautical miles above the earth. The satellites complete an orbit cycle every 12 hours and provide direct line-of-sight radio frequency signals to users worldwide. A ground control network tracks the satellites, determines orbits precisely, and transmits orbit definition data to each satellite. Navigation and position fixing using GPS is accomplished by passive trilateration. Users measure range to and compute the position of four satellites and process the measurements to determine three-dimensional position and time.

Although GPS was originally designed to enhance the war-fighting capability of U.S. and allied military forces, the unprecedented accuracies already available from the system have given rise to a wide variety of civil GPS applications. As the GPS reaches full maturity, applications are anticipated to continue to emerge, and worldwide civil land, sea, and airborne users are expected to outnumber military users by a sizeable margin.

TRIMBLE 2101 Approach Plus

Civil GPS Information Center

In order to accommodate the needs of the large worldwide civil GPS user community, the U.S. Government has established GPS Information Center (GPSIC). Operated and maintained by the United States Coast Guard for the Department of Transportation, the primary functions of the GPSIC are to provide information to and serve as the point of contact for civil GPS users.

Information Available

Information available from the GPSIC is called the Operational Advisory Broadcast, which contains the following general categories of GPS performance data:

- Current constellation status (satellite health data)
- Future status (planned outages of satellites)
- Almanac data (suitable for making GPS coverage and satellite visibility predictions)

Information Media

GPS Operational Advisory Broadcast information is available from the GPSIC in the following forms:

- Computer bulletin boards
- Voice tape recording
- Voice broadcasts
- Facsimile broadcast

All GPSIC services are provided free of charge. Registration for the GPSIC bulletin board is done on-line at the first session.

COMMS PARAMETERS

- Asynchronous - 8 Data Bits
- 1 Start Bit, 1 Stop Bit
- No Parity
- Full Duplex
- XOn/XOff
- Both Bell and CCITT Protocols

The GPSIC computer bulletin board may be accessed by dialing (703) 313-5910 for modem speeds of 300-14,400 bps.

The telephone number for the voice tape recording is (703) 313-5907.

Information Requests

In addition to the prerecorded Operational Advisory Broadcast information available, the GPSIC is prepared to respond to individual user inquiries, comments, or concerns regarding civil access to and use of the GPS. The GPSIC will accept calls of this nature from civil users 24 hours a day. The number is (703) 313-5900.

TRIMBLE 2101 Approach Plus

Written comments, questions, or concerns on the GPS or operation of the GPSIC may be addressed to:

Commanding Officer
U.S. Coast Guard ONSCEN
7323 Telegraph Road
Alexandria, Va 22310-3998
(703) 313-5400

Other Information Sources

GPS status information may also be obtained from the following sources:

- WWV/WWVHHF radio broadcasts WWV minutes 14 & 15; WWVH minutes 43 & 44)
- (5, 10, 15, 20 MHz)
- Defense Mapping Agency (DMA) weekly Notices to Mariners
- DMA broadcast warnings (NAVAREA, HYDROLANT, and HYDROPAC)
- DMA NavInfoNet, ANMS
1200 BAUD - (301) 227-5295
2400 BAUD - (301) 227-4630
9600 BAUD - (301) 227-4424
- USCG Broadcast Notices to Mariners
- NAVTEX Data Broadcast
- (518 kHz)

Users must register off-line before accessing the National Imagery and Mapping Agency NavInfoNet. A user ID and information booklet is available by writing the DMA Hydrographic/Topographic Center (ATTN: MCN/NAV-INFONET) Bethesda, MD 20816-5003 or calling (301) 227-3296.

GPS Information Center Users' Manual

Detailed information on the GPSIC services and how the services may be obtained is available in a GPS Information Center Users' Manual. The Users' Manual may be obtained by calling (703) 313-5900 or writing the Information Center.

NOTE

Satellite visibility window predictions are not offered by the GPSIC. This information is available from commercial sources or from commercially available software.

Civil GPS Service Steering Committee

In addition to the services provided by the GPSIC, the U.S. Government has established a Civil GPS Service Steering Committee (CGSSC). The purpose of the CGSSC is to address issues and problems that relate to the civil use of the GPS and to provide a forum for discussions between civil GPS users and the DOD.

The CGSSC consists of an Executive Council, General Committee, and five Subcommittees:

- Precise Positioning and Surveying
- Timing
- Reference Station
- International
- Carrier Phase Tracking

TRIMBLE 2101 Approach Plus

The CGSSC is jointly chaired by the U.S. Department of Transportation and the U.S. Coast Guard. Points of contact are:

U.S. Department of Transportation
Research and Special Programs Administration
400 7th Street, S.W., Room 9402
Washington, DC 20590-0001
Phone: (202) 366-4333
Fax: (202) 366-3666

Commandant (G-NRN)
U.S. Coast Guard
2100 Second Street, S.W.
Washington, DC 20593-0001
Phone: (202) 267-0283
Fax: (202) 267-4427

The CGSSC meets about every three months, and the General Committee meetings are open to all interested parties.

Appendix **C**

The User Setup Mode









The User Setup mode allows you to configure the Navigator to your preferred settings. From the User Setup mode, you can modify the following features:

Database Search Regions

AIRWATCH™

Save/Load Configuration

Once the settings have been chosen, the User Setup mode can be disabled, providing protection for the preferred settings. (Enable is the factory default.) To disable/enable the User Setup mode:

- Press  to access Configure mode.
- Turn the  to display the Display Diagnostic page.
- While the display test is running, press the key sequence , , .
- Press .
- Select DISABLE or ENABLE as desired, using the .
- Press .

When disabled, the User Setup screen and functions are unavailable.

C.1 Database Search Regions

You may select specific states and regions for a database search. These search parameters can include up to 6 regions, states, provinces or countries. "ALL" is the factory default setting for this page.

You can also restrict a database search by specifying the following regions in the United States:

nw	North West
sw	South West
nc	North Central
sc	South Central
ec	East Central
ne	North East
se	South East

These U.S. Regions correspond to the ARINC regions. Their boundaries are different from those used in government publications. Refer to Appendix A for regional maps, and a list of state, province and country codes.







The display below indicates that database searches will be made for the individual countries of France, Germany and Italy.

```
SEARCH REGIONS: FRA  
DEU ITA
```

The display below indicates that database searches will be made for the northeast region, California, Nevada, Arizona, Utah, and Colorado.

```
SEARCH REGIONS: sw  
CA NV AZ UT CO
```

To establish Database Search Regions:

- Press  to access the User Setup mode.
- Rotate the  knob to display the Search Regions page.
- Press .
- Rotate the  knob to move through the editable fields.
- Rotate the  knob to select the desired region, state, province, or country code.
- Continue this process to enter up to 6 search parameters.
- Press  to complete the selection.

Defining a search region will not restrict searches in the NRST mode, or restrict searches for restricted airspaces.

C.2 AIRWATCH™ - The Airspace Alert System

The Airspace Alert page allows you to enable or disable specific Special Use airspaces from the AIRWATCH™ search feature. The factory default AIRWATCH™ setting is OFF.

The Navigator monitors aircraft position in relation to the boundaries of Special Use airspaces in the United States and provides a warning of impending airspace penetration. AIRWATCH™ does not take into consideration hours of operation or vertical boundaries associated with controlled airspaces.

The display below indicates that AIRWATCH™ is ON and ALL airspaces are being monitored. If individual airspaces have been enabled or disabled, the word “SELECTED” will appear instead of “ON” in this display.



To turn AIRWATCH™ ON/OFF or to designate SELECTED airspaces:

- Press **AUX** to access the Configure mode.
- Rotate the **⦿** knob to access the AIRWATCH™ page.
- Press **ENT**.
- Rotate the **⦿** knob to select ON, OFF or SELECTED.
- Press **ENT**.
- If SELECTED is chosen, rotate the **⦿** knob to display optional airspaces.
- Press **ENT** and rotate the **⦿** knob to enable or disable each SELECTED airspace.
- Press **ENT** to confirm each selection.
- Rotate the **⦿** to display the next airspace.

C.3 Saving and Loading the Configuration

Navigator configuration can be saved to or loaded from a Memory Card (also called the RAM Card) or an IBM PC. The Memory Card is a data storage device that fits in the slot on the front of the Navigator normally used by the Jeppesen NavData Database Card.

Data on the Memory Card can be updated with an IBM PC, or the PC may be interfaced directly to the Navigator, when used in conjunction with the optional Trimble Flight Planning and Configuration software known as NavPak. When the PC is interfaced directly to the Navigator, appropriate cabling must be provided between the Navigator rear connector and the PC (typically a standard 9-pin connector is installed in the aircraft to accommodate interface to the PC).





The RAM card and NavPak are sold separately. Contact your Trimble dealer for details.

WARNING

Do not load or save configuration data during flight while navigating. Data should be loaded or saved during pre-flight or post-flight.

C.3.1 Saving Configuration to the Memory Card

To save the current Navigator configuration to the Memory Card:

- With the Navigator off, remove the NavData card and insert the RAM card.
- Turn the Navigator on.
- Press  to access the User Setup mode.
- Rotate the  knob display the “Save/Load Config” page.
- Rotate the  knob to select “SAVE CONFIGURATION VIA RAM CARD (ENT)”.
- Press .

The Navigator will display the status of the Memory Card and ask for confirmation to write to the card.

- Press  to begin data transfer to the Memory Card.

During the data transfer, the display will indicate the amount of data transferred by showing the percentage of transfer in the upper right-hand corner. When the transfer is complete, the display will show 100%.

During the SAVE process, the Navigator can detect some problems with the Memory Card. If an error occurs, the user can exit the SAVE process by pressing any of the Navigator Keys.

To return the Navigator to normal operation:

- Turn the Navigator off.
- Replace the RAM Card with the NavData Card.
- Turn the Navigator on.

C.3.2 Loading Configuration from the Memory Card

To load the Navigator configuration from the Memory Card:

- With the Navigator OFF, remove the NavData card and insert the RAM card.
- Turn the Navigator on.
- Press **AUX** to access the User Setup mode.
- Rotate the **⦿** knob until the “SAVE/LOAD CONFIG, TURN OUTER KNOB” message is displayed.
- Rotate the **⦿** knob to select “LOAD CONFIGURATION VIA RAM CARD (ENT)”.
- Press **ENT**.

The Navigator displays “CLEAR BEFORE LOAD?”. There are two options:

- Press **ENT** to clear the existing configuration and load the new one.

OR

- Rotate the **⦿** knob to display “APPEND CARD DATA”.
- Press **ENT** to add the configuration from the Memory Card to the existing Navigator configuration.

During the data transfer, the display will indicate the amount of data transferred by showing the percentage of transfer in the upper right-hand corner. When the transfer is completed, the display will show 100%. It is not possible to stop the data transfer once it is started.

TRIMBLE 2101 Approach Plus

If an error is detected before the transfer begins, the transfer will not start. In this case, an advisory message appears and the MSG indicator on the Navigator starts to flash. The advisory message directs you to make the necessary corrections.

During the LOAD process, if a record error is detected, an advisory message is displayed on the bottom line. If an error is found in a record, that record is not transferred to the Navigator, but the load operation continues.

During a LOAD process for which you have selected the APPEND option, the data being loaded is automatically checked for compatibility with the existing data. If an incompatibility is found in a record, that record is not transferred to the Navigator, but the load operation continues.

```
LOAD CONFIG 17  
INVALID ID: UDLATU
```

A load error is displayed as follows:

The invalid ID is located on line 17 of the NavPak file.





```
LOAD CONFIG 48  
MAX ERRORS: ABORTING
```

If more than 10 errors or incompatibilities are detected, the data transfer is aborted. The error message below is displayed:

When any errors are reported, the Navigator contains a partial (and probably corrupted) data set. The configuration process should be repeated.

C.3.3 Saving Configuration via Serial Port

To save the current Navigator configuration onto an IBM PC:

- Connect the Navigator to the PC using the cable prepared by your installer.
- Press  to access the User Setup mode.
- Rotate the  knob until the “SAVE/LOAD CONFIG, TURN OUTER KNOB” message is displayed.
- Rotate the  knob to select “SAVE CONFIGURATION VIA SERIAL PORT (ENT)”.
- Press .
- Prepare the PC to receive Navigator configuration data and write it to file.



During the data transfer, the display will indicate the amount of data transferred by showing the percentage of transfer in the upper right-hand corner. When the transfer is completed, the display will show 100%.

During the SAVE process, the Navigator can detect some processing problems. If an error occurs, the user can exit the SAVE process by pressing any of the Navigator keys.

To ensure proper Navigator operation, turn the Navigator off and then back on after the Save operation.

C.3.4 Loading Configuration via Serial Port

To load the Navigator configuration from an IBM PC:

- Connect the Navigator to the PC using the cable prepared by your installer.
- Press **AUX** to access the User Setup mode.
- Rotate the  knob until the "SAVE/LOAD CONFIG, TURN OUTER KNOB" message is displayed.
- Rotate the  knob to select "LOAD CONFIGURATION VIA SERIAL PORT (ENT)".



```
LOAD CONFIGURATION
CLEAR BEFORE LOAD ?
```

- Press **ENT**.
- Press **ENT** to clear the existing configuration and load the new one.

OR

- Rotate the  knob to display "APPEND DATA FILE".
- Press **ENT** to add the configuration from the IBM PC compatible to the existing Navigator configuration.
- Prepare the PC to send the data file to the Navigator.

During the data transfer, the display will indicate the amount of data transferred by showing the percentage of transfer in the upper right-hand corner. When the transfer is completed, the display will show 100%. The data transfer can only be stopped by turning off the Navigator.

If an error is detected before the transfer begins, the transfer will not start. An advisory message appears and the MSG annunciator starts to flash. The advisory message directs the user to make the necessary corrections.

During the LOAD process, if a record error is detected, an advisory message is displayed on the bottom line. If an error is found in a record, that record is not transferred to the Navigator, but the load operation continues.

During a LOAD process for which the user has selected the APPEND option, the data being loaded is automatically checked for compatibility with the existing data. If errors are detected, the MSG annunciator begins to flash. The number of the bad record and the number of the character within the record are displayed on the second line. If an incompatibility is found in a record, that record is not transferred to the Navigator, but the load operation continues.

A load error is displayed as follows:

```
LOAD CONFIG 17  
INVALID ID: UDLATU
```

The invalid ID is located on line 17 of the NavPak file.

TRIMBLE 2101 Approach Plus

If more than 10 errors or incompatibilities are detected, the data transfer is aborted. The following error message is displayed:

A rectangular box with a thick black border containing two lines of text in all caps.

```
LOAD CONFIG 48  
MAX ERRORS: ABORTING
```

When any errors are reported, the Navigator contains a partial (and probably corrupted) data set. The configuration process should be repeated.

To ensure proper Navigator operation, turn the Navigator off and then back on after the Load operation.

Glossary of Terms

absolute altitude

Actual altitude above the surface of the earth.

auto fix

The ability of a GPS receiver to start position calculations without being given an approximate location and approximate time.

AUX (auxiliary mode)

AUX mode contains the functions not used directly for navigation, but as a supplementary to navigation functions.

barometric altitude

Altitude above the surface of the earth as measured by barometric pressure; a relative measure of altitude.

bandwidth

The range of consecutive frequencies comprising a signal.

C/A code

The standard (Clear/Acquisition) GPS code: a sequence of 1023 pseudo-random, binary, biphase modulations on the GPS carrier at a chip rate of 1.023 MHz. Also known as the "civilian code."

carrier-aided tracking

A signal processing strategy that uses the GPS carrier signal to aid the code loop tracking.

carrier frequency

The frequency of the unmodulated fundamental output of a radio transmitter.

CDI

Course Deviation Indicator; a visual display of distance offset from the desired course.

TRIMBLE 2101 Approach Plus

channel

A channel of a GPS receiver, consisting of the circuitry necessary to track the signal from a single GPS satellite.

clock bias

The difference between the clock's indicated time and true universal time.

continuous receiver

A GPS receiver which has from five to twelve channels used in environments that are highly dynamic or require high accuracy.

control segment

A worldwide network of GPS monitoring and control stations that ensure the accuracy of satellite positions and their clocks.

cross-track error

A measure of the distance of an aircraft from its desired track; usually in nautical miles.

data message

A 1500-bit message included in the GPS signal that reports the satellite's location, clock corrections, and condition. Included is rough information on the other satellites in the constellation.

datum

A mathematical model (ellipsoid or spheroid) which best represents all or one area of the Earth's surface.

desired track

The desired track between current position and the selected destination. Aircraft HSI's OBS (OMNI bearing selector) or HDG bug should be set to match the desired track.

differential positioning

Precise measurement of the relative positions of two receivers tracking the same GPS signals.

Dilution of Precision

The multiplicative factor that modifies range error. It is caused solely by the geometry between the user and the set of satellites used. Known as DOP, GDOP or PDOP.

Doppler-aided

A signal processing strategy that uses a measured Doppler shift to help the receiver smoothly track the GPS signal. Allows more precise velocity and position measurement.

Doppler shift

The apparent change in the frequency of a signal caused by the relative motion of the transmitter and receiver. Doppler shift measurements provide extremely accurate velocity measurements.

ephemeris data

Predictions of current satellite positions that are transmitted to the user in the data message.

field

A part of the Navigator's LED display that contains one discrete piece of information; for example, one letter of an identifier, or the bearing to a waypoint.

frequency band

A particular range of frequencies.

frequency spectrum

The distribution of signal amplitudes as a function of frequency.

function keys

The Navigator's -D> (DIRECT), ENT, and MSG keys.

geometric dilution of precision

See Dilution of Precision.

GPS

Global Positioning System; a satellite-based navigation system.

great circle

The shortest distance between two points on the earth's surface.

ICAO

International Civil Aviation Organization; assigns identifiers to waypoints throughout the world. The Trimble Navigation System uses these identifiers for international waypoints; it uses FAA identifiers for waypoints in the continental U.S.

TRIMBLE 2101 Approach Plus

Identifier

The FAA code or ICAO code that identifies an Airport, VOR, NDB, or Intersection.

ING

Irish National Grid

Intersection

The crossing of two VOR radials or victor airways.

Ionosphere

The band of charged particles 80-120 miles above the earth's surface.

Ionospheric refraction

The change in the propagation speed of a signal as it passes through the ionosphere.

L-band

The group of radio frequencies extending from 390 MHz to 1550 MHz. The GPS carrier frequencies (1227.6 MHz and 1575.42 MHz) are in the L-band and/or UHF frequency band.

LAT/LON

Latitude/Longitude

LED

Light Emitting Diode, used in the Navigator's display.

LSEA

Lowest Safe Enroute Altitude.

MEA

Minimum Enroute Altitude.

MESA

Minimum Enroute Safe Altitude to destination waypoint, allowing 1000 feet of clearance over the highest terrain.

MGRS

Military Grid Reference System

mode keys

The NAV, WPT, FPL, CALC, AUX, and NRST keys on the Navigator, which determine the mode in which it is operating.

MSA

Minimum Safe Altitude calculated for present position, allowing 1000 feet over highest terrain and obstacles in current geographic sector.

multi-channel receiver

A GPS receiver that can simultaneously track more than one satellite signal.

multiplexing channel

A channel of a GPS receiver that can quickly sequence through a number of satellite signals.

NDB

Non-Directional Beacon.

OSGB

Ordnance Survey of Great Britain

P-code

The Precise or Protected code. A very long sequence of pseudo-random binary biphasic modulations on the GPS carrier at a chip rate of 10.23 MHz, which repeats about every 267 days. Each one-week segment of this code is unique to one GPS satellite and is reset each week.

PDOP

See Dilution of Precision (DOP).

pseudo-random code

A signal with random-noise-like properties. It is a very complicated, repeating pattern of 1s and 0s.

pseudo-range

A distance measurement based on the correlation of a satellite-transmitted code and the local receiver's reference code, not corrected for errors in synchronization between the transmitter's clock and the receiver's clock.

TRIMBLE 2101 Approach Plus

RAIM

RAIM Receiver Autonomous Integrity Monitoring.

satellite constellation

The arrangement in space of a set of satellites. The GPS constellation consists of 24 satellites in 6 orbital planes.

scroll

To move (characters) to the left across the LED display in order to show more information.

sequencing receiver

A receiver of less than four channels that collects GPS data by switching from one satellite to the next in sequence.

space segment

The part of the whole GPS system that is in space (i.e., the satellites).

spread spectrum

A system in which the transmitted signal is spread over a frequency band much wider than the minimum bandwidth needed to transmit the information. This is done by modulating with a pseudo-random code (for GPS).

SIDs

Standard Instrument Departures

STARs

Standard Terminal Arrivals

static positioning

Location determination when the receiver's antenna is presumed to be stationary in the earth. This allows the use of various averaging techniques that improve accuracy by factors of over 1000.

TK

Track, the actual magnetic course.

true altitude

Altitude above mean sea level.

UPS

Universal Polar Stereographic.

user interface

The way a receiver conveys information to the person using it; the controls and displays.

user segment

The part of the whole GPS system that includes the receivers of GPS signals.

UTC

Coordinated Universal Time.

UTM

Universal Transverse Mercator

VNAV

Vertical Navigation; the ability to establish a vertical descent profile. The Navigator provides for a VNAV calculation and provides vertical guidance information to the pilot.

VOR

Very High-Frequency Omnidirectional Range transmitter used for aircraft navigation.

TRIMBLE 2101 Approach Plus

This Page Intentionally Left Blank

Index

A

Abbreviations

- approach 3-3
- waypoint type 4-2, 4-3, 5-4

Active Flight Plan. *See* Flight Plan: active

ADD NEW FLIGHT PLAN 5-3

Air and Fuel Data Computer 7-13

Air Data

- calculations 7-1, 7-10. *See also* CALC key: modes: Air Data

pages 7-10

- altitude 7-10
- pressure altitude 7-10
- TAS 7-10
- wind 7-10

Airport 1-3, 4-2

- database information 1-3
- departure 1-4, 5-1, 5-11
- destination 3-5, 5-11
- identifier 1-3, 1-4, 3-5

Airspace Alert C-4. *See also* AIRWATCH

Airspeed 7-1

AIRWATCH C-4

Almanac Data 3-18

- Altitude I-6, 7-10, 8-12
 - density 7-1, 7-11, 7-12
 - calculations 7-11
 - display 8-12
 - entering 8-14
 - GPS 8-14

- indicated 7-10

- manual 8-14

- minimum safe 1-4

- pressure

- 7-1, 7-10, 7-11, 7-13, 8-14
- calculations 7-11

- source 8-12, 8-13

- BARO/GPS-2D 8-13

- BARO/GPS-3D 8-13

- GPS-3D 8-13

- HELD/GPS-2D 8-13

- MANUAL/GPS-2D 8-13

- OLD 8-13

- PRS/GPS-2D 8-13

- PRS/GPS-3D 8-13

Annunciators 1-2, 1-8, 1-12

- APR 1-13, 3-4

- HLD 1-13

- MSG 1-12, 9-2

- PTK 1-13, 8-26

- WPT 1-13

Antenna

- GPS 8-16

Approaches

- 1-3, 3-1, 4-2, 4-11, 4-13, 4-21, 5-1
- activate 3-6, 4-20
- active 3-7
 - join 3-7
- add to flight plan 3-5
- airport identifiers 1-3
- annunciator 3-4. *See also* Annunciators: APR
- availability 8-25
- barometric setting 3-4
- update 3-9

TRIMBLE 2101 Approach Plus

- course reversal
 - 3-9, 3-10, 3-11, 3-12, 3-16
 - destination airport 3-5
 - direct-to
 - FAF 4-21
 - first waypoint 4-20, 4-21
 - direct-to first waypoint 4-21
 - disable 3-9
 - DME arc 3-2, 3-12
 - bearing and distance 3-14
 - bottom line displays 3-14
 - top line displays 3-14
 - enable 3-4, 3-8, 3-16
 - status 3-9
 - FAF-MAP leg 3-4
 - final
 - intercept 4-22
 - join 3-7
 - final approach fix 3-2
 - GPS 3-1, 3-3, 3-16
 - summary 3-16
 - join 3-4, 3-7, 4-20
 - missed 3-15
 - names 1-3
 - non-precision 3-16
 - overlay 3-3
 - procedures
 - defined by 4-11
 - RAIM
 - 3-18, 3-19, 3-20, 3-21, 8-18
 - availability 8-25
 - rules 3-3
 - select 3-4
 - transition 3-5
 - waypoint 4-1
 - waypoints 1-3, 3-2, 3-14
 - abbreviations 3-3
 - identifiers 3-2
 - names 3-2
 - APR
 - annunciator 1-13. *See also* Annunciators: APR
 - ARINC
 - maps A-7, A-8
 - Auto Cancel 8-26
 - AUX Key 1-9, 8-1
- ### B
- BARO/GPS-2D 8-13
 - BARO/GPS-3D 8-13
 - Barometric Pressure
 - 7-10, 8-12
- ### C
- CALC key 1-8. *See also* Keys:
 - CALC
 - modes 7-1
 - Air Data 7-1
 - displays 7-2
 - entering data 7-2
 - Flight Plan/Fuel 7-1, 7-2
 - Save Present Position 7-1
 - Calculator Key. *See* CALC key
 - Cancel Flight Plan. *See* Flight Plan
 - CDI 8-26
 - scaling 1-12
 - Change Flight Path. *See* Flight Path
 - Checklists 8-1, 8-2, 8-3
 - creating 8-3
 - deleting 8-9
 - deleting items 8-7, 8-8
 - editing 8-6
 - inserting items 8-7
 - mode 8-3
 - naming 8-3
 - number 8-4
 - using 8-5
 - Codes
 - country
 - list A-4, A-5, A-6
 - province

- list A-2
 - state
 - list A-2
 - Configuration
 - data transfer C-11
 - error C-11
 - loading C-7
 - error C-11
 - memory card C-7
 - using IBM PC C-10
 - via serial port C-10
 - saving C-6
 - memory card C-6
 - using IBM PC C-9
 - via serial port C-9
 - Configure 8-1, 8-2, 8-26
 - database search regions C-2
 - dead reckoning 8-26, 8-28
 - display diagnostic 8-30
 - parallel offset 8-26, 8-27
 - save/load C-5
 - Controlled Airspace. *See* AIRWATCH
 - Country Codes
 - list A-4, A-5, A-6
 - Course Deviation 3-14
 - Course Deviation Indicator. *See* CDI
 - Course Reversal
 - 3-10, 3-11, 3-16
 - holding pattern 3-11
 - procedure turn 3-10
 - teardrop 3-12
 - Cross Track Error 8-26
 - Crosswind. *See* Wind: crosswind
 - Crystal Offset 8-15
 - Current Track 7-15
- D**
- Data Entry 2-3
 - Data Pages
 - 1-8, 1-10, 1-12, 2-1, 2-3
 - flight plan 5-2
 - fuel management 7-4
 - primary 1-11
 - secondary 1-10, 1-11
 - Database I-3, I-5, 1-3, 1-5, 4-2
 - card slot 1-2, 1-6
 - changing database cards A-10
 - expiration 8-16
 - NavData card 4-2
 - search regions C-2, C-3
 - ARINC regions C-2
 - U.S. regions C-2
 - Database Expiration Information 8-10
 - DATABASE EXPIRED 1-6
 - DATABASE MISSING 1-6
 - Database Search Regions
 - ARINC regions A-7, A-8
 - international regions A-8
 - maps A-7, A-8
 - U.S. regions A-7
 - Dead Reckoning
 - 8-24, 8-26, 8-28
 - demo mode 8-28
 - ground speed 8-29
 - starting point 8-28
 - track 8-29
 - Demo Mode 8-28
 - Departure Airport. *See* Airport: departure
 - Desired Track 3-14
 - Destination Airport. *See* Airport: destination
 - Direct-to 4-20
 - waypoint 2-4
 - Direct-to Key 1-9, 1-11, 2-4
 - Display Diagnostic 8-30
 - Distance 7-3, 7-5
 - DME arc

TRIMBLE 2101 Approach Plus

3-2, 3-3, 3-12, 3-13. See
also Approaches
DR. See Dead Reckoning

E

ENT key 1-11, 2-2
Enter Key. See ENT key
Entering Information 1-12
Estimated Accuracy 8-18, 8-20
Estimated Time Enroute (ETE)
7-2, 7-3
Estimated Time of Arrival (ETA)
3-19, 7-2

F

FAF. See Final Approach Fix
Final Approach Fix
1-13, 3-2, 3-3, 4-21. See
also Approaches
Final Course
intercept 4-22
Flight Path 2-4
change 2-4
Flight Plan
activate 2-4, 5-3, 5-14
active 5-1, 5-2
active legs 5-1
add approach 3-5, 5-4
add procedure 5-5
add SID 5-4
add STAR 5-4
approach
add 5-11
calculations 7-1
cancel 2-4, 5-15, 5-16
create 5-3, 5-4, 5-6
data pages 5-2
direct-to 5-3
edit 5-4, 5-9
enter 2-6
erase 5-16

legs 5-2
active 5-2, 5-13
direct-to 5-15
join 5-3, 5-14
review 5-13
stored 5-2, 5-3, 5-13
modes 5-2
procedures 5-4
add 5-8, 5-10, 5-11
delete 5-12
replace 5-12
reverse 5-14
SID
add 5-9, 5-11
delete 5-9
edit 5-9, 5-12
STAR
add 5-9, 5-11
delete 5-9
edit 5-9, 5-12
stored 5-1, 5-2
stored legs 5-1
suspend 5-18
waypoints 5-4
add 5-6, 5-9, 5-10
delete 5-9, 5-10
replace 5-9, 5-10
Flight Plan Distance (DIST) 7-2
Flight Plan Key. See FPL Key
Flight Plan/Fuel Pages 7-2
Flight Time Reserve 7-7
FPL Key 1-8, 5-1
modes 5-1, 5-2
Fuel 1-7, 2-2
at arrival 7-7
calculations
7-1, 7-4, 7-5, 7-8
consumption 7-4
efficiency 7-4
estimated 7-4
flow 7-9

management 7-3, 7-4
 on board 1-7
 remaining 7-5, 7-6, 7-9
 reserve 7-7, 7-8
 used 7-8, 7-9
 Function Keys 1-8

G

GPS

altitude 8-14
 annunciator. *See* Annunciators: GPS
 antenna 8-16
 messages A-9
 GPS: RECEIVER FAIL A-9
 satellite
 disable 8-22
 enable 8-22
 satellite availability
 8-18, 8-21, 8-24
 satellite status
 8-18, 8-21, 8-22
 sensor reset 8-18, 8-23
 status 8-18
 2D+ BARO 8-19
 2D+HELD 8-19
 2D+MANL 8-19
 2D+PRS 8-19
 3D 8-19
 3D/BARO 8-19
 3D/PRS 8-19
 status messages A-9
 GPS-3D 8-13
 Ground Speed
 7-2, 7-3, 7-4, 7-15

H

Heading 7-14, 7-15
 Headwind. *See* Wind: headwind
 HELD/GPS-2D 8-13
 HLD

annunciator 1-13
 Hold 5-18
 annunciator. *See* Annunciators: HLD
 flight plan waypoint 5-18
 missed approach 5-19
 outside flight plan 5-18
 Holding Pattern 5-18. *See also*
 Hold
 course reversal 3-11

I

Indicated Airspeed 7-13
 Initial Approach Fix (IF) 3-3
 Initialization 1-7
 Install 8-2
 Install Mode
 display diagnostic 8-30
 Installation Manual I-4
 Intercept Course 4-22
 Intermediate Fix 3-3
 International
 Database I-5, 1-3. *See also*
 Jeppesen Navigation
 Database
 search regions A-1
 Intersection 4-1
 Intersections 1-4, 4-3, 4-7

J

Jeppesen Navigation Database
 I-3, I-5, 1-3, 1-5, 4-2
 card slot 1-2
 changing database cards A-10
 country codes A-4, A-6
 expiration 1-6
 information I-5, 1-3, 1-5
 North American I-5, 1-3, 4-2
 province codes A-2
 state codes A-2

TRIMBLE 2101 Approach Plus

subscription 1-3, 1-6
Join leg 4-15, 4-20

K

Keys 1-8, 1-10, 2-1
AUX 1-9, 8-1, 8-2
CALC 1-8, 7-1
Direct-to 1-9, 2-4
ENT 1-11, 2-2
FPL 1-8
MSG 1-9, 9-1
NAV 1-8, 6-1, 6-11
NRST 5-17
WPT 1-8, 4-1, 4-4, 4-13
Knobs 1-8. *See also* Selector
Knobs

L

LED display 1-2, 1-7
automatic dimming 1-8
brightness level 1-8

M

Mach Number 7-13
Magnetic Variation 7-15
MAHP. *See* Missed Approach
Holding Point
MANUAL/GPS-2D 8-13
Maps
ARINC A-7, A-8
Memory Battery 8-15
Memory Card C-5
Message Annunciator 1-12
Message Key. *See* MSG key
Messages 9-1
accessing 9-2
advisory 9-2, 9-6
GPS messages A-9

GPS: NO SV AVAILABLE
A-9

priority 9-2
RAIM error 9-4
system 9-2, 9-4
explanation 9-4

Miles Per Gallon (MPG) 7-2

Minimum Safe Altitude 1-4

Missed Approach

3-2, 3-3, 3-15, 3-17

before the MAP 3-15

beyond the MAP 3-15

procedure 3-4

select 3-15

Missed Approach Holding Point

1-5, 3-2, 3-3, 3-15, 3-16

Modes 1-8, 1-10, 2-1

approach 3-6, 4-11

checklist 8-1, 8-3

configure 8-1, 8-26

FLT PLAN/FUEL

7-2, 7-3, 7-4

NAV 6-1, 6-2. *See also*

NAV mode

restore 2-5

SID 4-11

STAR 4-11

system status 8-10

User 4-17

waypoint 4-1

MSG Annunciator. *See* Annun-
ciators: MSG

MSG key 1-9, 9-1

N

NAV key 1-8, 6-1

NAV mode 6-2

display 6-3

pages 6-2

bottom line display

6-2, 6-3

- top line display 6-2, 6-3
 - primary page 6-2
 - NavData card 1-3, 1-6, 3-3
 - Navigation Key. *See* NAV key
 - Navigation Page
 - primary 2-4
 - NavPak C-5
 - NDB 1-4, 4-1, 4-3, 4-7
 - Nearest 5-17
 - agencies 5-17
 - waypoints 5-17
 - waypoints, user 5-17
 - Nearest Key 1-9, 5-17. *See also* APT/VOR key
 - NOACTIVE FLIGHT PLAN 5-2
 - No Cancel 8-26
 - NO STORED FLIGHT PLANS 5-2
- O**
- OAT. *See* Outside Air Temperature (OAT)
 - OAT "K" Factor 7-13
 - Operation Overview 1-8, 1-11
 - annunciators 1-8. *See also* Annunciators
 - keys 1-8. *See also* Keys selector knobs 1-8. *See also* Selector Knobs
 - Outside Air Temperature 7-13
 - Outside Air Temperature (OAT) 7-11, 7-13
- P**
- Parallel Offset 8-26, 8-27
 - auto cancel 8-26
 - no cancel 8-26
 - selecting 8-26, 8-27
 - Parallel Track
 - annunciator. *See* Annunciators: PTK
 - PDOP. *See* Position Dilution of Precision (PDOP)
 - Phonetic Waypoints 7-17. *See also* Waypoint: phonetic
 - Position Dilution of Precision (PDOP) 8-18, 8-20
 - Power Switch 1-2, 1-7, 2-2
 - Power-Up 2-2
 - Present Position
 - display 8-12
 - saving 7-17
 - Present Position/Altitude 8-10
 - Pressure Altitude 7-1, 8-14
 - Procedure 2-1, 2-3, 4-16. *See also* Approaches; Standard Instrument Departure; Standard Terminal Arrival
 - activating 4-14
 - add 5-9
 - defining 4-13
 - delete 5-9, 5-12
 - edit SID 5-9
 - edit STAR 5-12
 - entering 5-4
 - insert 5-10
 - join leg 4-15, 4-20
 - name 4-13
 - replace 5-12
 - Procedure Turn 3-9, 3-10
 - Province Codes
 - list A-2
 - PRS/GPS-2D 8-13
 - PRS/GPS-3D 8-13
 - PTK
 - annunciator 1-13. *See also* Annunciators: PTK
- Q**
- Quick Reference Card I-4

TRIMBLE 2101 Approach Plus

R

RAIM

- 3-18, 8-12, 8-18, 8-19, 9-4
 - annunciator. *See* Annunciators: RAIM
 - approach
 - 3-18, 3-19, 3-20, 3-21
 - APR 8-20
 - availability
 - 3-19, 3-20, 8-18, 8-25
 - definition 3-18
 - enroute 3-18
 - limit 3-19
 - prediction
 - 3-18, 3-19, 3-21, 8-25
 - status 8-19
 - NO RAIM 8-19
 - RAIM/B 8-19
 - TERM 8-20
 - terminal 3-18
- Ram Air Temperature (RAT)
7-11, 7-13
- RAM Card C-5
- Range 7-6
- RAT. *See* Ram Air Temperature
- Receiver Autonomous Integrity Monitor. *See* RAIM
- Reverse Flight Plan. *See* Flight Plan: reverse
- Runway 1-3
 - direction 7-16

S

- Satellite. *See* GPS: satellite
 - availability 8-18
 - coverage 3-19
 - status 8-18
- Save Present Position
 - 7-1, 7-17
- Save/Load Configuration C-5
- Selector Knobs

- 1-2, 1-8, 1-9, 2-1, 2-3
- large 1-9, 1-11
- small 1-9, 1-11
- Self-Diagnostic Test 1-7, 2-2
- Sensor Status 8-2, 8-18
 - approach RAIM availability 8-18, 8-25
 - estimated accuracy 8-18, 8-20
- GPS satellite availability
 - 8-18, 8-21, 8-24
- GPS satellite status
 - 8-18, 8-21, 8-22
 - disable satellite 8-22
 - enable satellite 8-22
- GPS sensor reset
 - 8-18, 8-23
- GPS status 8-18
- Service Information I-4
- SID. *See* Standard Instrument Departure
- Software Code Display 8-10
- Software Revision Information
 - 8-10, 8-17
- Speed 7-2, 7-4
- Standard Instrument Departure
 - 14, 42, 411, 413, 415, 416, 51
 - activating 4-15
 - add 5-5
 - defined by 4-12
 - delete 5-5
 - edit 5-12
- Standard Terminal Arrival
 - 14, 41, 42, 411, 413, 415, 416, 51
 - activating 4-15
 - add 5-5
 - defined by 4-12
 - delete 5-5
- STAR. *See* Standard Terminal Arrival
- State Codes
 - list A-2

- Stored Flight Plans. *See* Flight Plan: stored
 - Suspend waypoint sequencing 5-18
 - SV. *See* GPS:
 - satellite; Satellite
 - System Code Display 8-17
 - System Status 8-2, 8-10
 - database revision information 8-10, 8-16
 - present position/altitude 8-10, 8-12
 - software code display 8-10, 8-17
 - software expiration information 8-10, 8-17
 - time display 8-10
 - voltage and temperature display 8-10, 8-15
- T**
- TAS. *See* True Airspeed
 - Teardrop Course Reversals 3-12
 - Temperature 8-10
 - Time display 8-10
 - Time, distance, speed calculations 7-1, 7-3
 - Time Zones 8-11
 - Transition
 - select 4-14
 - True Airspeed
 - 7-1, 7-10, 7-12, 7-13, 7-14, 7-15
 - calculations 7-14
- U**
- User Setup 8-30
 - database search regions C-4
 - save/load configuration C-5
 - User Waypoints
 - 4-1, 4-3, 4-17. *See also* Waypoints: user
 - bearing and distance 4-17
 - creating 4-17, 4-18
 - editing 4-19
 - erasing 4-19
 - latitude and longitude 4-17
 - present position 4-17
 - UTC Time 8-10
- V**
- Vertical Navigation Display 6-6
 - Vertical Navigation Profiles 7-18
 - VNAV 7-18
 - VNAV Profiles 6-6, 7-19
 - creating 7-19
 - using 6-6
 - Voltage and Temperature Display 8-10, 8-15
 - VOR 1-4, 4-2
- W**
- Warranty Information I-4
 - Waypoint 2-1, 4-1
 - abbreviations 5-4
 - activating 4-14
 - active 4-14
 - add 4-17, 5-6
 - advisory 6-4
 - airport 4-1, 4-2, 4-4
 - selecting 4-8
 - annunciator. *See* Annunciators: WPT
 - approches
 - 1-3, 4-1, 4-2, 4-5
 - bearing to 4-3
 - categories 4-2
 - delete 5-10
 - direct to
 - 4-14, 4-15, 4-16, 4-21

TRIMBLE 2101 Approach Plus

- displays 4-4
 - approaches 4-5
 - intersection 4-7
 - SID 4-5
 - STAR 4-6
 - user 4-7, 4-17
 - VOR 4-6
- distance to 4-3
- editing 4-19
- enroute 5-1
- entering 5-4
- hold 5-18
- identifiers 3-2, 4-10
 - abbreviations 4-2, 4-3
 - scan 4-10
- information 4-2, 4-10, 6-11
- intersections 4-1, 4-3, 4-7
 - selecting 4-8
- NDB 4-1, 4-3
 - selecting 4-8
- phonetic 7-17
 - copy 7-17
- radial from 4-3
- replace 5-10
- selecting 4-8
 - by city name 4-9
 - by identifier 4-9
 - by waypoint name 4-10
- sequencing
 - hold 5-18
- SID 4-1, 4-2, 4-5, 4-15
- STAR 4-2, 4-6, 4-15
- STARs 4-1
- user 4-1, 4-3, 4-7, 4-17
 - editing 4-19
 - selecting 4-8
- VOR 4-1, 4-2, 4-6
 - selecting 4-8
- Waypoint key. See WPT key
- Wind
 - aloft
 - calculations 7-14, 7-15
 - calculations 7-1, 7-10, 7-16
 - crosswind 7-1, 7-16
 - direction 7-14, 7-16
 - headwind 7-1, 7-16
 - speed 7-14, 7-16

WPT

Annunciator 1-13

WPT key 1-8, 4-1

Z

Zulu Time 8-10



Trimble

2105 Donley Drive
Austin, Texas 78758
(512) 432-0400