

9800 Martel Road  
Lenoir City, TN 37772  
www.ps-engineering.com

# MB10



Document P/N 200-023-0001

Rev. 7, April 2009

Marker Beacon Receiver/Indicator

**System Installation and Operation Manual**  
FAA-Approved TSO, C35d

**In certified aircraft, warranty is not valid unless this product is installed by an  
Authorized PS Engineering dealer.**

**PS Engineering, Inc. 2009 ©**  
*Copyright Notice*

Any reproduction or retransmittal of this publication, or any portion thereof, without the expressed written permission of PS Engineering, Inc. is strictly prohibited. For further information contact the Publications Manager at PS Engineering, Inc., 9800 Martel Road, Lenoir City, TN 37772. Phone (865) 988-9800, email [contact@ps-engineering.com](mailto:contact@ps-engineering.com).

## Table of Contents

Section I GENERAL INFORMATION.....	1-1
1.1 INTRODUCTION .....	1-1
1.2 SCOPE .....	1-1
1.3 EQUIPMENT DESCRIPTION.....	1-1
1.4 APPROVAL BASIS – FAA TSO C35d .....	1-1
1.5 SPECIFICATIONS .....	1-1
1.6 EQUIPMENT SUPPLIED.....	1-2
1.7 EQUIPMENT REQUIRED BUT NOT SUPPLIED .....	1-2
1.8 LICENSE REQUIREMENTS.....	1-2
Section II - Installation.....	2-1
2.1 GENERAL INFORMATION.....	2-1
2.1.1 SCOPE .....	2-1
2.1.2 CERTIFICATION REQUIREMENTS.....	2-1
2.2 UNPACKING AND PRELIMINARY INSPECTION .....	2-1
2.3 EQUIPMENT INSTALLATION PROCEDURES.....	2-1
2.3.1 COOLING REQUIREMENTS.....	2-1
2.3.2 MOUNTING REQUIREMENTS.....	2-1
2.3.3 CONNECTOR ASSEMBLY .....	2-1
2.4 CABLE HARNESS WIRING .....	2-2
2.4.1 POWER.....	2-2
2.4.2 AUDIO PANEL INTERFACE.....	2-2
2.4.3 LAMP DIMMING.....	2-2
2.4.4 MARKER ANTENNA INSTALLATION.....	2-2
2.4.5 EXTERNAL MARKER LIGHTS.....	2-2
2.4.6 REMOTE MODE SELECTOR- MB10R VERSION ONLY .....	2-2
2.4.7 MIDDLE MARKER SENSE.....	2-2
2.5 ADJUSTMENTS.....	2-3
2.6 MB10 PIN ASSIGNMENTS .....	2-3
2.7 UNIT INSTALLATION.....	2-3
2.7.1 PANEL INSTALLATION.....	2-3
2.7.2 REMOTE INSTALLATION .....	2-3
2.8 POST INSTALLATION CHECKOUT.....	2-4
2.9 OPERATIONAL CHECKOUT .....	2-4
2.9.1 REQUIRED TEST EQUIPMENT .....	2-4
2.9.2 MARKER CHECKOUT.....	2-4
2.10 FINAL INSPECTION.....	2-4
Section III OPERATION .....	3-1
3.1 SCOPE .....	3-1
3.2 POWER.....	3-1
3.3 MARKER BEACON OPERATION .....	3-1
Section IV- Warranty and Service .....	4-1
4.1 WARRANTY .....	4-1
4.2 FACTORY SERVICE .....	4-1
Appendix A – MB10 Installation Drawings.....	A
Appendix B, J10 Interconnect.....	B
Appendix C- Instructions for FAA Form 337 and continuing airworthiness .....	C
7.1 INSTRUCTIONS FOR FAA FORM 337 .....	C
7.2 INSTRUCTIONS FOR CONTINUING AIRWORTHINESS, AUDIO SYSTEM.....	C
Appendix D RTCA DO160E Environmental Qualification Form .....	D

Rev	Date	Change
1	5-22-07	Updated to add remote version
2	8-14-07	Update to show TSO information
3	11-12-07	Clarified dimming information, sections 2.4.3, 2.4.5, 2.4.6
4	1-9-08	Added drawing for remote installation to Appendix A
5	1-16-08	Clarified CB size and antenna connector
6	3-12-08	Corrected dimension to show overall width §1.5
7	4-16-09	Corrected page number and Advisory Circular references.

## Section I GENERAL INFORMATION

### 1.1 INTRODUCTION

Before installing and/or using this product, please read this manual completely. This will ensure that you will take full advantage of all the advanced features in the MB10.

### 1.2 SCOPE

This manual provides detailed installation and operation instructions for the PS Engineering MB10-series of Audio Selector Panel/Intercom Systems. This includes the following units:

<u>Model</u>	<u>Description</u>	<u>Part Number</u>
MB10	Marker Beacon Receiver w/Indicator	050-023-0100
MB10R	Remote (Blind Mounted) Marker Beacon Receiver	050-023-0101

### 1.3 EQUIPMENT DESCRIPTION

The MB10-is a 3-light 75 MHz Marker Beacon receiver and indicator. This provides the necessary Marker Beacon lights and audio indications necessary for an Instrument Landing System (ILS) approach. A switch labeled Hi/Lo/TST allows the pilot select high or low sensitivity as well as test and mute modes.

### 1.4 APPROVAL BASIS – FAA TSO C35d

#### TSO Approval.

The MB10-series Audio Selector Panels are FAA approved under TSO C35d (Marker Beacon Receivers).

All systems comply with relevant portions of EUROCAE RTCA MPS WG No. 7/70, DO-143 and (*Marker Beacon Receivers*), ED-14C/DO-160E *Environmental Conditions and Test Procedures for Airborne Equipment*.

Operation is subject to the following conditions:

This device may not cause harmful interference.

This device must accept any interference received, including interference that may cause undesired operation.

### 1.5 SPECIFICATIONS

<b>TSO COMPLIANCE</b>	
<i>Marker Beacon:</i>	C35d, Class A
APPLICABLE DOCUMENTS:	RTCA/DO-143 RTCA/DO-160E
<b>ENVIRONMENTAL Qualifications:</b>	A1D1CABSMXXXXXXZBABATBXXE2XXX
<i>Operating Temperature Range:</i>	-15° C to 55°C
<i>Altitude:</i>	Up to 50,000 feet in a non-pressurized area
DIMENSIONS:	Dimensions: 0.95" H X 2.8" W X 4.85" D (2.2 cm x 6.6 cm x 12.3 cm)
WEIGHT <i>MB10 Unit &amp; connector</i>	6.5 Ounces (.18 kg)
<b>POWER REQUIREMENTS (Including Internal Lighting):</b>	
<i>Voltage:</i>	11 to 33 VDC
<i>Maximum Current:</i>	0.25 Amp (Externally protected by a 1.0 A breaker)

**PS Engineering**  
 MB10 Marker Beacon Receiver  
 Installation and Operator's Manual

<b>MARKER BEACON RECEIVER:</b>	
<i>Frequency:</i>	75 MHz Crystal Controlled
<i>Sensitivity:</i> Low: High:	Capable of: (preset at factory for field application) 1000 $\mu$ Volts (Hard) (360 to 570 $\mu$ V soft) 200 $\mu$ Volts (Hard) (130 to 200 $\mu$ V soft)
<i>Selectivity:</i>	-6 dB at $\pm$ 10 kHz -40 dB at $\pm$ 120 kHz
<i>External Lamp Output:</i>	7.5 ( $\pm$ 4 VDC unloaded, at maximum brightness) VDC positive when active, max. current 125 mA per lamp output
<i>MM Sense:</i>	Active high (4.5 $\pm$ 1.0VDC)
<i>Output impedance:</i>	510 $\Omega$
<i>Audio Output:</i>	38 mW <5% THD typical

## 1.6 EQUIPMENT SUPPLIED

1 ea. of the following units:

Model	Description	Part Number
MB10	MB10 Marker Beacon Receiver and Indicator.	050-023-0100
MB10R	MB10 Marker Beacon Receiver (remote)	050-023-0101

MB10 Installation Kits:

Description	Quantity	250-023-0100 Part Number	250-023-0101 Part Number
DB-15 Female Connector, Solder	1	425-016-0001	425-016-0001
DB-15 Back shell, Plastic	1	425-015-0003	425-015-0003
Screw, Philips, #4-40 x 3/8" Black	2	475-442-0002	
Faceplate, MB10 Horizontal	1	575-023-0000	
Faceplate, MB10 Vertical	1	575-023-0001	
Remote Switch	1		731-004-0005
Sub- D connector Thumb screws	2	475-002-0002	475-002-0002
Mounting Flange	2		430-023-0030

## 1.7 EQUIPMENT REQUIRED BUT NOT SUPPLIED

- a. Circuit Breaker: 1.0 amp
- b. Marker Antenna (75 MHz, VSWR 1.5:1, and appropriate for the airspeed) with 50  $\Omega$  coax (RG-58C/U or equiv.)
- c. Interconnect Wiring

## 1.8 LICENSE REQUIREMENTS

None

## Section II - Installation

### 2.1 GENERAL INFORMATION

#### 2.1.1 SCOPE

This section provides detailed installation and interconnection instructions for the PS Engineering MB10 Marker Beacon system.

Please read this manual carefully before beginning any installation to prevent damage and post-installation problems. Installation of this equipment requires special tools and knowledge.

#### 2.1.2 Certification Requirements

##### NOTE

The MB10 requires specialized knowledge, tools and test equipment for an effective installation. An appropriately rated Certified Aircraft Repair Station **must** install this equipment in accordance with applicable regulations. PS Engineering, Incorporated warranty is not valid unless the equipment is installed by an authorized PS Engineering, Incorporated dealer.

Failure to follow any of the installation instructions, or installation by a non-certified individual or agency will void the warranty, and may result in an **unairworthy** installation.

### 2.2 Unpacking and Preliminary Inspection

Use care when unpacking the equipment. Inspect the units and parts supplied for visible signs of shipping damage. Examine the unit for loose or broken buttons, bent knobs, etc. Verify the correct quantity of components supplied with the list in Section 1.6 (B). If any claim is to be made, save the shipping material and contact the freight carrier. Do NOT return units damaged in shipping to PS Engineering. If the unit or accessories show any sign of external shipping damage, contact PS Engineering to arrange for a replacement. Under no circumstances attempt to install a damaged unit in an aircraft. Equipment returned to PS Engineering for any other reason should be shipped in the original PS Engineering packaging, or other UPS approved packaging.

### 2.3 Equipment Installation Procedures

#### 2.3.1 Cooling Requirements

Forced air-cooling of the MB10 is not required. However, the units should be kept away from heat producing sources (i.e. defrost or heater ducts, dropping resistors, heat producing avionics) without adequate cooling air provided.

#### 2.3.2 Mounting Requirements

The MB10 must be rigidly mounted to the instrument panel of the aircraft structure and within view and reach of the pilot position(s). Installation must comply with FAA Advisory Circular AC 43.13-2A. The unit may be mounted in any area where adequate clearance for the unit and associated wiring bundle exist.

Avoid running the interconnecting bundles near any high current wires.

#### 2.3.3 Connector Assembly

The MB10 uses a 15 pin, solder cup Sub D connector. The antenna connector is BNC type, Female on unit.

## 2.4 Cable Harness Wiring

Referring to the appropriate Appendix, assemble a wiring harness as required for the installation. All wires must be MIL-SPEC in accordance with current regulations. Two- and three-conductor shielded wire must be used where indicated, and be MIL-C-27500 or equivalent specification. Proper stripping, shielding and soldering technique must be used at all times. It is imperative that correct wire be used.

Refer to FAA Advisory Circular 43.13-2A for more information. Failure to use correct techniques may result in improper operation, electrical noise or unit failure. Damage caused by improper installation will void the PS Engineering warranty.

### 2.4.1 Power

The MB10-Series are compatible with both 14 and 28 Volt DC systems. A 0.5 Amp circuit breaker is required for all installations. Power and ground wires should be #22 connected to J10 Pin 1. Connect air-frame ground to J10 Pin 9 only. No dropping resistors are required.

### 2.4.2 Audio Panel interface

The MB10 is designed to interface with standard aircraft avionics, and presents a 510  $\Omega$  receiver impedance.

### 2.4.3 Lamp Dimming

The MB10 has manual dimming of the marker lamps. Control of the unit backlighting is through the aircraft avionics dimmer. For 14 V aircraft, connect J10 Pin 7 to the aircraft dimmer bus. For 28-volt systems, connect pin 8 to the aircraft dimmer.

### 2.4.4 Marker Antenna Installation

A marker beacon antenna, appropriate to the type and speed of the aircraft, is required (not included). Refer to aircraft and antenna manufacturer's installation instructions, as well as AC43.13-2A (or later revision), Chapter 3, for information on proper antenna installation techniques. The marker beacon antenna must be mounted on the bottom of the aircraft.

### 2.4.5 External Marker Lights

For installations that require external marker beacon lights, there are three outputs that can drive 12-Volt lamps only. The external output lamps are driven high (typically +9 VDC  $\pm$ 1.5 VDC unloaded, at MAX brightness) when active. Maximum source current per lamp is 125 mA. Voltage varies with dimming bus.

Note: if a constant maximum intensity is desired for the panel- or remote-mounted MB10, connect pin 7 (14V) or 8 (28V) to aircraft power.

The MB10 is also has active-low, open-collector marker outputs (inner, middle, outer) for interfacing with other avionics systems that might require an active-low output. If required, a pull-up resistor may be placed on the active-low outputs. It should be  $>1k \Omega$ , and may be pulled up to any voltage below 32V DC.

Note: It is possible to use BOTH outputs at the same time. For example, driving remote indicator lamps and an electronic display.

### 2.4.6 Remote Mode Selector- MB10R version only

The MB10R has provisions for remote mounting the Marker Mode selector (Hi-/Lo-Test/Mute). This must be an On-Off-Momentary On switch. Connect Pin 15 to ground to place the unit in High Sense, and momentarily ground Pin 13 to mute the marker audio. Holding this pin low for 1-second will test the lamp circuits.

### 2.4.7 Middle Marker Sense

A Middle Marker Sense output signal is available from the MB10 to flight control systems. This function will not operate during the test mode. This output will go to +4.5 VDC ( $\pm$  1.0 VDC) when a valid Middle Marker signal is received. This output is J1, pin 5.

## 2.5 Adjustments

The MB10 is factory adjusted to accommodate the typical requirements for most aircraft configurations. There are three adjustments in the top cover that allow the installer to tailor the specific functions.



**Figure 2-1 MB10 adjustment Locations**

- Marker Beacon Volume, turn adjustment counterclockwise to increase marker beacon audio level.
- MKR Gain- Set for High sensitivity level
- LOW SENSE, Sets low sensitivity

## 2.6 MB10 Pin assignments

J10	Function	J10	Function
1	14/28 VDC Aircraft Power	9	Aircraft Ground
2	White Lamp Output Active High	10	White Lamp Output Active Lo
3	Amber Lamp Output Active High	11	Amber Lamp Output Active Lo
4	Blue Lamp Output Active High	12	Blue Lamp Output Active Lo
5	MM Sense Output	13	Remote Test/Mute
6	Marker Audio Output	14	Marker Audio Ground
7	14 V lighting Input	15	Remote High Sense Mode
8	28 V lighting Input		

## 2.7 Unit Installation

### 2.7.1 Panel Installation

The MB10 panel mount is installed from the back of the panel. After the holes are drilled, carefully feed the lamps and their wires through the lamp holes. Then secure the unit to the panel with the two #4-40 screws through the front plate, instrument panel, and into the unit.

Then, press the lamps into their respective openings on the front plate, until tight. They are flared to press fit into the chassis.

### 2.7.2 Remote installation

The Remote version, 050-023-0101, may be mounted on any convenient avionics shelf by securing with screws, nuts or nutplates, (not included), in accordance with AC43.13-2A, §24.

## **2.8 Post Installation Checkout**

After wiring is complete, verify power is ONLY on pin 1 of J10 and airframe ground on J10 pin 9. Failure to do so will cause serious internal damage and void PS Engineering's warranty.

## **2.9 Operational Checkout**

### **2.9.1 Required Test Equipment**

In order to return an aircraft to service after installation of the MB10, the installer must have access to a Marker Beacon signal generator:

- a. IFR NAV401L, NAV402AP, IFR4000
- b. TIC T-30D, T-36C

Equivalent test equipment is acceptable as long as the testing requirements can be met.

### **2.9.2 Marker Checkout**

1. Connect a ramp generator at the antenna end of the marker coax. With the unit under test in HI sensitivity, verify that a 160  $\mu$ V, modulated 95% with 1300 Hz, signal will illuminate the amber (M) marker light, and that marker audio is present in the headphones when the Marker Audio is selected on the aircraft audio system. Verify that the white (I) and blue (O) lights will illuminate within  $\pm$  3dB of the amber lamp, with 3000 Hz and 400 Hz modulation is applied, respectively.
2. Repeat with the unit in LOW sensitivity, with 430  $\mu$ Volts applied.
3. Connect the marker antenna and verify proper operation.

## **2.10 Final Inspection**

Verify that the wiring is bundled away from all controls and no part of the installation interferes with aircraft control operation. Move all controls through their full range while examining the installation to see that no mechanical interference exists. Verify that the cables are secured to the aircraft structure in accordance with good practices, with adequate strain relief. Ensure that there are no kinks or sharp bends in the cables and coaxial cables. Verify that the cables are not exposed to any sharp edges or rough surfaces, and that all contact points are protected from abrasion.

Complete logbook entry, FAA Form 337, weight and balance computation and other documentation if required. Sample text for FAA Form 337, and instructions for continuing airworthiness can be found in Appendix F.

Return completed warranty registration application to PS Engineering, or complete online at [www.ps-engineering.com](http://www.ps-engineering.com).



## Section III OPERATION

### GENERAL INFORMATION

#### 3.1 SCOPE

This section provides detailed operating instructions for the PS Engineering MB10, Marker Beacon system. Please read it carefully before using the MB10 so that you can take full advantage of its capabilities.



Figure 3-1 MB10 front panel

#### 3.2 Power

Unit power is on whenever the avionics bus is energized.

#### 3.3 Marker Beacon Operation

The Marker Beacon Receiver uses visual and audio indicators to alert you when the aircraft passes over a 75 MHz transmitter.

The Blue lamp, labeled “O”, is the Outer Marker lamp and has an associated 400-Hertz 'dash' tone. The lamp and tone will be keyed at a rate of two tones/ashes per second when the aircraft is in the range of the Outer Marker Beacon.

The Amber lamp, labeled “M”, is the Middle Marker lamp and is coupled with a 1300 Hertz tone. It is keyed alternately with short 'dot' and long 'dash' bursts at 95 combinations per minute.

The White lamp, labeled “I”, is the Inner marker and has a 3000-Hertz 'dot' tone. The lamp and tone will be keyed at a rate of six times per second.

The audio from the Marker Beacon Receiver can be heard by selecting the "MKR" push-button switch. To adjust the volume level, there is a service adjustment located on the top of the unit.

A toggle switch is used to set the receiver sensitivity and to test the indicator lamps. Use "HI" sensitivity initially. This allows you to hear the outer marker beacon about a mile out. Then switch into Low Sensitivity mode. “LO” sensitivity gives you a more accurate location of the Outer Marker. Holding the MKR switch down for two seconds activates marker test lamp, labeled "T/M" and illuminates all three lamps simultaneously to assure the lamps (internal and external) are in working order. TST does not activate MM autopilot sense output. Releasing the button returns to the low sensitivity.

Pressing the marker mode select (to “T/M”) for two seconds will also cause the marker audio to mute for that beacon. The next beacon received will re-activate the audio.

## Section IV- Warranty and Service

### 4.1 Warranty

In order for the factory warranty to be valid, the installations in a certified aircraft must be accomplished by an FAA-(or other ICAO agency) certified avionics shop and authorized PS Engineering dealer. If the unit is being installed by a non-certified individual in an experimental aircraft, a factory-made intercom harness must be used for the warranty to be valid.

PS Engineering, Inc. warrants this product to be free from defect in material and workmanship for a period of three (1) year from the date of retail purchase. During the warranty period, PS Engineering, Inc., at its option, will send a replacement unit at our expense if the unit should be determined to be defective after consultation with a factory technician.

All transportation charges for returning the defective units are the responsibility of the purchaser. All domestic transportation charges for returning the exchange or repaired unit to the purchaser will be borne by PS Engineering, Inc. The risk of loss or damage to the product is borne by the party making the shipment, unless the purchaser requests a specific method of shipment. In this case, the purchaser assumes the risk of loss.

This warranty is not transferable. Any implied warranties expire at the expiration date of this warranty. PS Engineering SHALL NOT BE LIABLE FOR INCIDENTAL OR CONSEQUENTIAL DAMAGES. This warranty does not cover a defect that has resulted from improper handling, storage or preservation, or unreasonable use or maintenance as determined by us. This warranty is void if there is any attempt to disassemble this product without factory authorization. This warranty gives you specific legal rights, and you may also have other rights, which may vary from state to state. Some states do not allow the exclusion of limitation of incidental or consequential damages, so the above limitation or exclusions may not apply to you.

All items repaired or replaced under this warranty are warranted for the remainder of the original warranty period. PS Engineering, Inc. reserves the rights to make modifications or improvements to the product without obligation to perform like modifications or improvements to previously manufactured products.

### 4.2 Factory Service

The units are covered by a one-year limited warranty. See warranty information. Call PS Engineering, Inc. at (865) 988-9800 before you return any unit. This will allow the service technician to provide any other suggestions for identifying the problem and recommend possible solutions.

After discussing the problem with the technician and you obtain a Return Authorization Number, ship product to:

PS Engineering, Inc.  
Attn: Service Department  
9800 Martel Rd  
Lenoir City, TN 37772  
(865) 988-9800 FAX (865) 988-6619  
Email: support@ps-engineering.com

**Units that arrive without an RMA number, or telephone number for a responsible contact, will be returned un-repaired. PS Engineering is not responsible for items sent via US Mail.**

## Appendix A – MB10 Installation Drawings

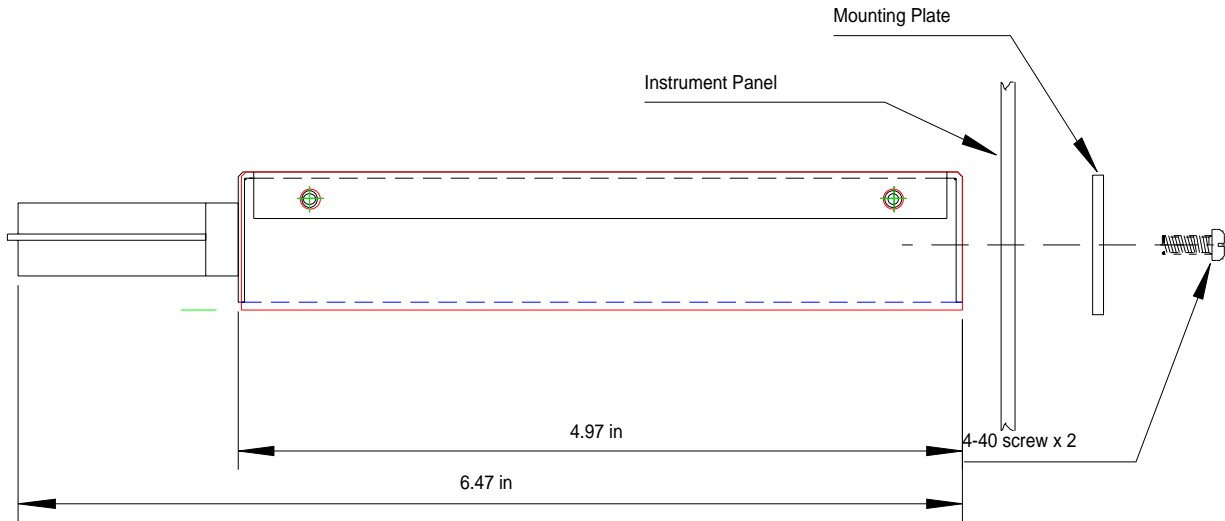

Figure 5-1 Panel Mounting view

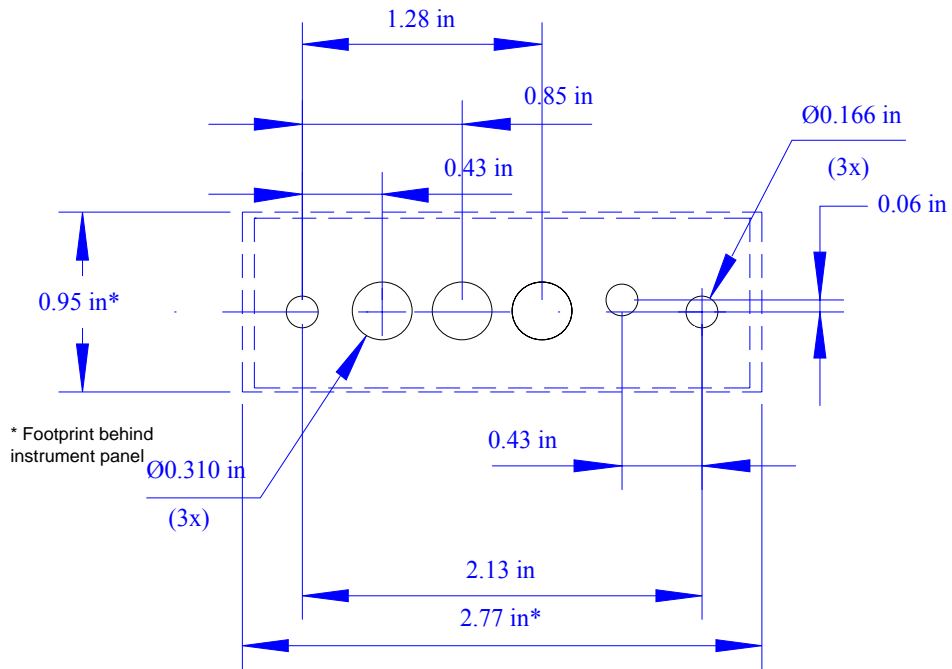
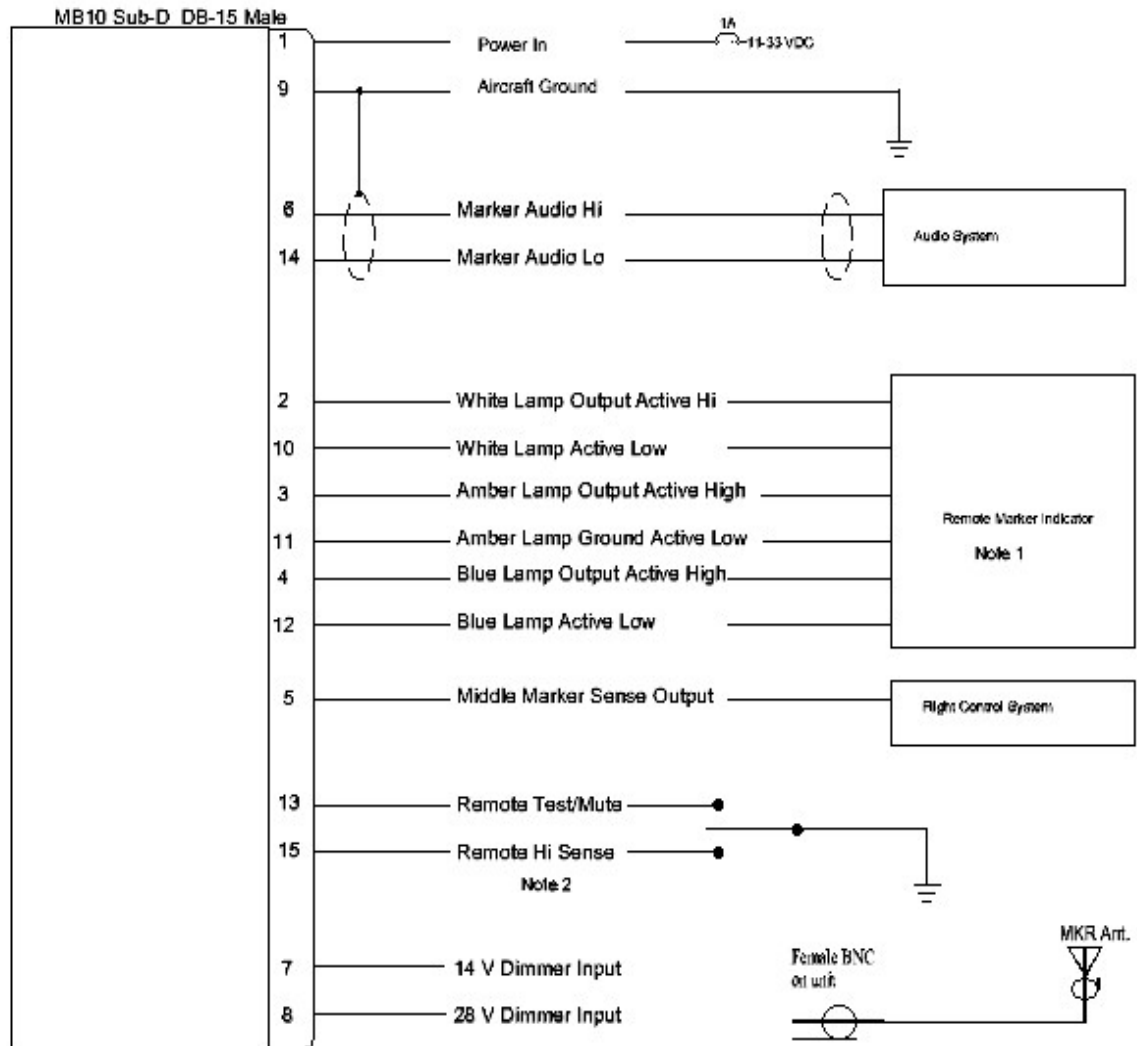

Figure 5-2 Hole Layout (not to scale)



## Appendix B, J10 Interconnect



NOTES: 1. Use EITHER active High OR Active Low output.  
 See Section 2.4.5 for details

2. For remote Marker Mode control.  
 Use ON-OFF-MOM switch. See Section 2.5.6



## Appendix C- Instructions for FAA Form 337 and continuing airworthiness

### 7.1 Instructions for FAA Form 337

One method of airworthiness approval is through an FAA Form 337, *Major Repair and Alteration (Airframe, Powerplant, Propeller, or Appliance)* In the case of the MB10, you may use the following text as a guide.

Installed audio selector and 6-place intercom, PS Engineering MB10, part number 050-023-(X) in ( location ) at station \_\_\_\_\_. Installed per *AC43.13-2B, Chapter 2*. Installed per PS Engineering *Installation Operators Manual* p/n 200-023-(XXXX), revision ( ), dated ( ).

These units are FAA-Approved under TSO C35d for Marker Beacon Receivers, and meets appropriate environmental qualifications outlined in RTCA DO-160E as appropriate or this aircraft.

Interface to existing aircraft radios in accordance with installation manual and in compliance with practices listed in *AC43.13-2B, Chapter 2*. All wires are Mil-Spec 22759 or 27500. Connection to aircraft dimmer bus is \_\_\_\_\_. Power is supplied to the unit through a 1A circuit breaker (type and part number), and total electrical load does not exceed \_\_\_\_% of the electrical system capacity with the MB10 added.

Aircraft equipment list, weights and balance amended. Compass compensation checked. A copy of the operation instructions, contained in PS Engineering document 202-023-( ), revision ( ), dated ( ), is placed in the aircraft records. All work accomplished listed on Work Order \_\_\_\_\_.

### 7.2 Instructions for Continuing Airworthiness, Audio System

Sample ICA Checklist for PS Engineering Audio System:

Section	Item	Information
1	Introduction	Installation marker beacon receiver system.
2	Description	Installation as described in manufacturer's installation manual referenced on FAA Form 337, including interface with other avionics audio as required.
3	Controls	See installation and operator's guide referenced on FAA Form 337.
4	Servicing	None Required
5	Maintenance Instructions	On Condition, no special instructions
6	Troubleshooting	Follow checkout instructions in the installation manual referenced on the FAA Form 337. For a specific unit fault, contact the manufacturer at (865) 988-9800 for special instructions.
7	Removal and replacement information	<u>Removal:</u> <i>Panel Mount</i> — Using a #1 Phillips screwdriver, unscrew the bezel escutcheon. <i>Remote Mount</i> — Remove 4 retaining screws. <u>Installation:</u> Reverse the Removal Instructions
8	Diagrams	Not applicable
9	Special Inspection Requirements	Not Applicable
10	Protective Treatments	Not Applicable
11	Structural Data	Not Applicable
12	Special Tools	None
13	Not Applicable	Not Applicable
14	Recommended Overhaul Periods	None
15	Airworthiness Limitations	Not Applicable
16	Revision	To be determined by installer

## Appendix D RTCA DO160E Environmental Qualification Form

Marker Beacon Receiver

Part Number: 050-023-()

FAA TSO Number: C35d

Manufacturer: PS Engineering Incorporated 9800 Martel Road Lenoir City TN 37772

Conditions	Section	Conducted Tests
Temperature and Altitude	4.0	Equipment tested to CAT A1 & D1
Low Temperature	4.5.1	-55° C Survival, -15°C Low Operating (A1)
High Temperature	4.5.2	+85°C Survival, +70°C High Short Time Operating
In-flight Loss of Cooling	4.5.4	Not Applicable, no cooling required
Altitude	4.6.1	50,000' unpressurized (D1)
Decompression	4.6.2	Not Applicable
Overpressure	4.6.3	Not Applicable
Temperature variation	5.2	Equipment tested to Category C
Humidity	6.0	Equipment tested to Category A
Shock	7.0	Equipment tested to Operational test only
Operational	7.2	Equipment tested to Operational test only
Crash Safety	7.3	Equipment tested to Operational test only
Vibration	8.0	Equipment tested to Category M & N
Explosion	9.0	Category X, not tested
Waterproofness	10.0	Category X, not tested
Fluids Susceptibility	11.0	Category X, not tested
Sand and Dust	12.0	Category X, not tested
Fungus	13.0	Category X, not tested
Salt Spray	14.0	Category X, not tested
Magnetic Effect	15.0	Equipment tested to Category Z
Power input	16.0	Equipment tested to Category B
Voltage Spike	17.0	Equipment tested to Category A
Audio Frequency Susceptibility	18.0	Equipment tested to Category B
Induced Frequency Susceptibility	19.0	Equipment tested to Category A
Radio Frequency Susceptibility	20.0	Equipment tested to Category T
Radio Frequency Emission	21.0	Equipment tested to Category B
Lightning Induced Transient Susceptibility	22.0	Equipment tested to Category XXE2
Lightning Direct Effects	23.0	Category X, not tested
Icing	24.0	Category X, not tested
ESD	25.0	Category X, not tested