

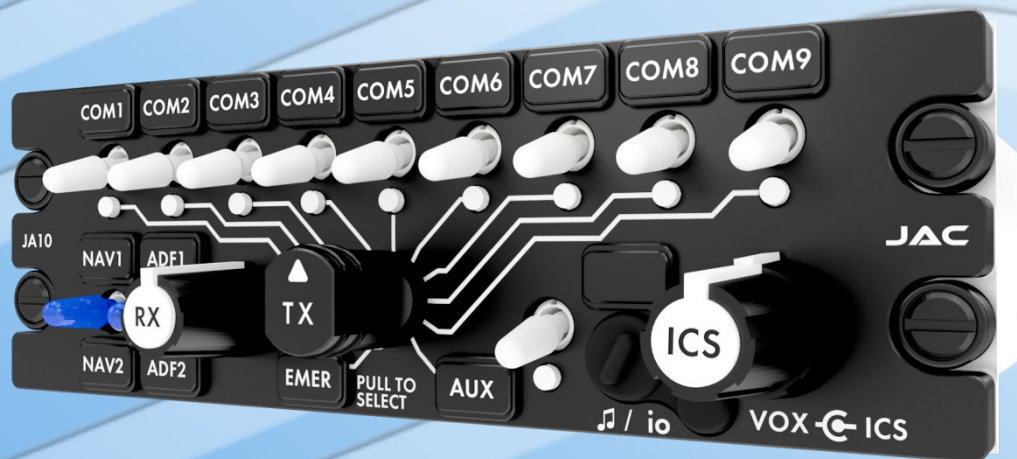

**JUPITER AVIONICS**  
CORPORATION

# JA10-001

## Audio Controller- Ten Transceiver



## Installation and Operating Manual

Rev A

Jupiter Avionics Corporation  
1959 Kirschner Road  
Kelowna BC  
Canada V1Y 4N7  
Tel: +1 778 478 2232  
Toll-Free: 1 855 478 2232  
[www.jupiteravionics.com](http://www.jupiteravionics.com)





## Table of Contents

<b>SECTION 1 - DESCRIPTION .....</b>	<b>1</b>
1.1 System Overview .....	1
1.2 Features Overview .....	1
1.3 Inputs and Outputs .....	2
1.3.1 Inputs .....	2
1.3.2 Outputs .....	2
1.3.3 Bi-directional Ports .....	2
1.4 Specifications .....	3
1.4.1 Electrical Specifications .....	3
1.4.2 Mechanical Specifications .....	5
1.4.3 Flammability of Materials .....	5
1.4.4 Configuration Connector .....	5
1.4.5 Product Configuration Software Version .....	5
<b>SECTION 2 – INSTALLATION .....</b>	<b>6</b>
2.1 Introduction .....	6
2.2 Continued Airworthiness .....	6
2.3 Unpacking and Inspecting Equipment .....	6
2.3.1 Warranty .....	6
2.4 Installation Procedures .....	6
2.4.1 Installation Limitations .....	6
2.4.2 Cabling and Wiring .....	6
2.4.3 Mechanical Installation .....	7
2.4.4 In-Line PTT Cordsets .....	7
2.4.5 Legend Replacement .....	7
2.4.6 Post Installation Checks .....	7
2.5 Adjustments and Configuration using ProCS™ .....	8
2.5.1 Configuration Cabling Requirements .....	8
2.5.2 ProCS™ Setup .....	8
2.5.3 Configurable Settings .....	8
2.5.4 Other Configuration Features .....	15
2.6 Installation Kit .....	16
2.6.1 Recommended Crimp Tools .....	16
2.7 Installation Drawings .....	16
2.7.1 Generation of Custom Drawings .....	16
<b>SECTION 3 – OPERATION .....</b>	<b>17</b>
3.1 Introduction .....	17
3.2 USER 1 Front Panel Controls .....	17
(1) Transceiver receive audio select switches, TX select annunciators and associated legends .....	18
(2) Receiver audio select switches and associated legends .....	18
(3) Receive Volume Control .....	18
(4) EMER Legend .....	19
(5) USER 1 Transmit and Emergency mode Selector .....	19
(6) Music/Configuration Connector (♫/io) .....	19
(7) USER 1 TX Annunciator .....	20
(8) VOX/ICS Threshold Control .....	20
3.3 USER 1 Normal Operation Mode .....	20
3.3.1 Panel Lighting .....	20
3.3.2 Receiving .....	20
3.3.3 Transmitting (Transmit Operation) .....	20
3.3.4 Duplex Operation .....	21
3.3.5 VOX Operation .....	21
3.3.6 ICS Operation .....	21
3.3.7 ICS Isolate Operation .....	21
3.3.8 Music Operation .....	21



3.4	USER 2 Normal Operation Mode.....	22
3.5	USER 3 to 8 Normal Operation Mode.....	22
3.5.1	Receive Audio .....	22
3.5.2	Direct Audio.....	22
3.5.3	Transmitting (Transmit Operation) .....	22
3.5.4	ICS Operation.....	22
3.5.5	ICS Isolation .....	22
3.5.6	Music Operation .....	22
3.6	Emergency Operation Mode .....	22
3.6.1	Auto Emergency Mode.....	22
3.6.2	Selected Emergency Mode .....	23
<b>Appendix A - Installation Drawings.....</b>		<b>A1</b>
A1	Introduction.....	A1
A2	Installation Drawings .....	A1
<b>Appendix B - Certification Documents .....</b>		<b>B1</b>
B1	Airworthiness Approval .....	B2
B2	Instructions for Continued Airworthiness .....	B2



### SECTION 1 - DESCRIPTION

#### **1.1 System Overview**

The JA10-001 Audio Controller - Ten Transceiver is part of an aircraft audio system consisting of an audio controller and an optional control device.

The audio controller distributes and controls all transceiver and receiver audio in an aircraft. It routes microphone audio to a selected transceiver and distributes all intercom audio.

The USER 1 operates the audio controller via the front panel controls. The USER 2 operates the audio controller via a panel mount control device.

The audio controller can be used in a stand-alone configuration (one audio controller and one control device). An emergency operating mode connects USER 1 to the COM 1 transceiver, the NAV 1 receiver and all four direct inputs, and USER 2 to the COM 2 transceiver, NAV 2 receiver and all four Direct Audio sources.

The JA10-001 is set up on a per-installation basis using a configuration cable and a PC running the product configuration tool to download system configuration settings via the front panel music / configuration connector. To facilitate future customizations and certification, neither software nor complex electronic hardware are used in the JA10-001 design.

#### **1.2 Features Overview**

Numerous input and output levels are adjustable using the configuration application ProCS™ (Product Configuration Software) by writing to the configuration connectors using a configuration cable.

The JA10-001 supports up to ten transceivers and four receivers.

The JA10-001 supports four Direct Audio inputs.

The JA10-001 supports two CVR outputs.

The JA10-001 supports transmit access for four users (User 1, User 2, User 3 and User 4).

The JA10-001 supports intercom functions for up to eight users.

The JA10-001 supports two receive mute inputs.

The JA10-001 microphone and headphone impedance can be configured as low or high.

The JA10-001 supports two separate music inputs.

A Music / Configuration connector is provided on the faceplate of the JA10-001 for configuration of audio levels and routing. The port can also be used as a music input and is compatible with most music players.

The JA10-001 has two modes of operation: Normal Mode and Emergency Mode.

The JA10-001 supports the USER 2 controls from a Control Device over a Control Data bus.



## 1.3 Inputs and Outputs

Refer to the JA10-001 [connector maps](#) for the mating connector designators and pin assignments for the input and output signals.

### 1.3.1 Inputs

<u>Name</u>	<u>Qty</u>	<u>Type</u>
COM 1 to COM 10, NAV 1 to NAV 4 HI/LO	14	Audio signal
CONFIG DATA to JA10	2	Data signal
CONFIG MODE SELECT	2	Multi-format control signal
DIRECT 1 to 4 HI/LO	4	Audio signal
ICS ISOLATE MODE	1	Control signal, active low
LIGHTS INPUT	1	Analog control signal
POWER INPUT	1	Power supply
USER 1 to 8 ICS PTT	8	Control signal, active low
USER 1 to 8 MIC HI/LO	8	Audio signal
USER 1 to 2 RX MUTE	2	Control signal, active low
USER 1 MUSIC LEFT & RIGHT	4	Audio signal
USER 1 to 4 TX PTT	4	Control signal, active low
USER 2 CONTROL DATA to JA10	1	Data signal
USER 2 MUSIC LEFT & RIGHT HI/LO	2	Audio signal
USER 2 NORM MODE SELECT	1	Control signal, active low
USER 2 RESET INPUT	1	Control signal, momentary active low

### 1.3.2 Outputs

<u>Name</u>	<u>Qty</u>	<u>Type</u>
COM 1 to 10 MIC HI/LO	10	Audio signal
COM 1 to 10 PTT	10	Control signal, active low
CONFIG DATA FROM JA10	2	Data signal
USER 1 & 2 CVR HI/LO	2	Audio signal
USER 1 & 2 RX COMP HI/LO	2	Audio signal
USER 1 to 8 PHONES HI/LO	8	Audio signal
USER 2 CONTROL DATA from JA10	1	Data signal
USER 2 POWER GROUND OUTPUT	1	Power Ground
USER 2 POWER OUTPUT	1	Power
USER 2 RESET OUTPUT	1	Control signal, active low
USER 1 & 2 TX ACTIVE	2	Control signal, active low

### 1.3.3 Bi-directional Ports

<u>Name</u>	<u>Qty</u>	<u>Type</u>
ICS TIE HI/LO	1	Audio signal



## 1.4 Specifications

### 1.4.1 Electrical Specifications

#### Power Input

Primary nominal voltage	28 Vdc
Maximum voltage	32.2 Vdc
Minimum voltage	21.5 Vdc
Emergency voltage	18.0 Vdc
Input current at 28 Vdc	≤ 1.5 A
Input current at Emergency voltage	≤ 2.0 A

#### 1.4.1.1 Audio Performance

##### Rated Input Level

Receive audio rated input level	7.75 Vrms ±10%
Direct audio rated input level	7.75 Vrms ±10%
Music rated input level	400 mVrms ±10%
High Impedance microphone input level	250 mVrms ±10%
Low Impedance microphone input level	250 uVrms ±10%
Intercom Tie Line type 1 input level	340 mVrms ±10%
Intercom Tie Line type 2 input level	1.20 Vrms ±10%

##### Rated Output Level

High Impedance phone rated output	12.3 Vrms±10%
Low Impedance phone rated output	1.42 Vrms±10%
High Impedance phone rated output, in emergency mode or with power input ≤15 Vdc	2.10 Vrms±20%
Low Impedance phone rated output, in emergency mode or with power input ≤15 Vdc	2.10 Vrms±20%
High Impedance phone rated output power, with MUSIC input	6.14 Vrms±10%
COM MIC rated output	250 mVrms±10%
CVR rated output	500 mVrms±10%
CVR rated output with input as MUSIC	0.250 Vrms±10%
CVR rated output with input as USER MIC	1.00 Vrms±10%
CVR rated output, in emergency mode,	500 mVrms ±10%
Receive Composite rated output	2.50 Vrms ±10%
Intercom Tie Line type 1 rated output	340 mVrms ±10%
Intercom Tie Line type 2 rated output	1.2 Vrms ±10%

##### Audio Frequency Response

Audio output audio frequency response	≤ 3dB from 300 to 6000 Hz
---------------------------------------	---------------------------

##### Distortion Characteristics

Audio output distortion at rated power	≤10%
Audio output distortion at 10% of rated power	≤3%

##### Input Impedance

High Impedance microphone input Impedance	150 Ω ±10%
Low Impedance microphone input Impedance	5 Ω ±10%
Direct Audio input Impedance	1000 Ω ±10%
Receive Audio input Impedance	1000 Ω ±10%
Music Audio input Impedance	1000 Ω ±10%
Intercom Tie Line Audio input Impedance	2000 Ω ±10%





### Output Impedance

High Impedance Phones output Impedance	$\leq 6 \Omega$
Low Impedance Phones output Impedance	$\leq 6 \Omega$
Transceiver Microphone output Impedance	$\leq 80 \Omega$
CVR output Impedance	$\leq 80 \Omega$
Receive Composite Audio output Impedance	$\leq 80 \Omega$
Intercom Tie Line output Impedance	$2000 \Omega \pm 10\%$

### Output Load

High Impedance Phones load	$600 \Omega \pm 10\%$
Low Impedance Phones load	$8 \Omega \pm 10\%$
COM MIC load	$150 \Omega \pm 10\%$
CVR load	$5000 \Omega \pm 10\%$
Receive Composite Audio load	$600 \Omega \pm 10\%$
Intercom Tie Line type 1 rated load	$2000 \Omega \pm 10\%$
Intercom Tie Line type 2 rated load	$2000 \Omega \pm 10\%$
Intercom Tie Line type 1 maximum load	666 $\Omega$ max
Intercom Tie Line type 2 maximum load	285 $\Omega$ max

### Volume Controls

Receive Audio control variation	$32 \pm 3$ dB
ICS Audio control variation	$42 \pm 3$ dB

### Input to output Crosstalk and Bleed-through Level

Input to Output crosstalk	$\leq 55$ dB
---------------------------	--------------

### Input to Input Crosstalk Level

Input to Input crosstalk	$\leq 60$ dB
--------------------------	--------------

### Audio Noise Level without Signal

Noise level below the rated output	$\geq 60$ dB
Low impedance Mic Noise level below the rated output	$\geq 40$ dB

### 1.4.1.2 Audio Performance, Other

CVR HI / LO output circuitry type (Normal)	differential
CVR HI / LO output circuitry type (Emergency)	single ended
High Impedance Microphone inputs designed for MIC type	amplified dynamic / electret
Low Impedance Microphone inputs designed for MIC type	dynamic
Microphone inputs bias voltage	12 Vdc $\pm 10\%$
Microphone inputs circuitry type	single ended
MUSIC LEFT / RIGHT HI / LO audio input circuitry type	differential
FRONT MUSIC LEFT / RIGHT audio input circuitry type:	single ended
MUSIC attenuation	$\leq -38$ dB max
RECEIVE AUDIO input circuitry type	differential
PHN HI / LO output circuitry type	single ended
COM MIC output circuitry type	differential
RX Composite Audio output circuitry type	differential
ICS TIE HI / LO Circuitry Type	differential
PHN HI / LO output music fade in duration	$2.5 \pm 1.0$ seconds
VOX Threshold level range relative to rated MIC input	-28 to +6 dB
ICS TIE audio detect threshold level from MIC audio input	7 to 9 mVrms
RX audio detect threshold relative to rated Receive audio input	-36 to -12 dB





**1.4.1.3 Discrete Signals**

Active low control input, active signal level	≤ +3 Vdc
Active low control input, inactive signal level	≥ +10 Vdc
Active low control input, current	0.1 to 10 mAdc
Active low control output, active output	≤ +2 Vdc
Active low control output, active, current	≤ 1 Adc

**1.4.1.4 Lights Inputs**

LIGHTS INPUT ranges	0 to 28, 0 to 14 and 0 to 5 Vdc
LIGHTS INPUT current	10 mA max.

**1.4.2 Mechanical Specifications**

Height	1.875 in [47.63 mm] max
Behind panel depth	6.96 in [176.8 mm] max
Faceplate width	5.75 in [146 mm] max
Behind panel width	4.92 in [125 mm] max
Weight	2.49 lb [1.13 kg] max
Material	brushed aluminum with conversion coating
Connectors (3):	J1 One 62-pin D-Sub male
	J2 One 62-pin D-Sub male
	J3 One 26-pin D-Sub male
	J4 One 4-40, 0.5 in. max. stud
	J5 One 4 pole 3.5mm stereo jack
Mounting	4 Dzus fasteners
Bonding	≤ 2.5 mΩ
Installation kit part number	INST-JA10

**1.4.3 Flammability of Materials**

The JA10-001 complies with the requirements of RTCA/DO-160G Sec 26.3.3 "Flammability", through equivalent flammability testing of materials and the Small Parts Exemption.

**1.4.4 Configuration Connector**

The JA10-001 Audio Controller - Ten Transceiver configuration connector communication standard for CONFIG DATA TO JA10 data input signal and CONFIG DATA FROM JA10 data output signal is RS-232.

**1.4.5 Product Configuration Software Version**

Configuration of the JA10-001 Audio Controller - Ten Transceiver requires the Product Configuration Software (ProCS) version v0.60.0 or later. Refer to the release notes from <http://www.jupiteravionics.com/productsoftware.php> or contact Jupiter Avionics to ensure the correct version is used.



## JA10-001 Audio Controller - Ten Transceiver

### SECTION 2 – INSTALLATION

#### 2.1 Introduction

This section contains unpacking and inspection procedures, installation information, and post-installation checks.

#### 2.2 Continued Airworthiness

Maintenance of the JA10-001 is on condition only. Scheduled inspection and/or periodic maintenance of this unit is not required.

#### 2.3 Unpacking and Inspecting Equipment

Unpack the equipment carefully. Check for shipping damage and report any problems to the relevant carrier. Confirm that the Authorized Release Certificate or Certificate of Conformance is included. Complete the on-line warranty card from the Jupiter Avionics Corporation (JAC) website - [www.jupiteravionics.com/warranty](http://www.jupiteravionics.com/warranty)

##### 2.3.1 Warranty

This product manufactured by JAC is warranted to be free of defects in workmanship or performance for 2 years from the date of installation by an approved JAC dealer or agency. This warranty covers the cost of all materials and labour to repair or replace the unit, but does not include the cost of transporting the defective unit to and from JAC or its designated warranty repair centre, or of removing and replacing the defective unit in the aircraft. This warranty does not cover failures due to abuse, misuse, accident, or unauthorized alteration or repairs.

THIS WARRANTY IS VOID IF THE PRODUCT IS NOT INSTALLED BY AN AUTHORIZED JAC DEALER. If the on-line warranty card is not completed, the product will be warranted from the date of manufacture.

Contact JAC for return authorization, and for any questions regarding this warranty and how it applies to your unit(s). JAC is the final arbiter concerning warranty issues.

#### 2.4 Installation Procedures



---

**WARNING:** Loud noise can cause hearing damage. Set the headset volume to minimum before conducting tests, and slowly increase the volume to a comfortable listening level.

---



---

**CAUTION:** The power input circuitry of the unit may be damaged if the installation does not conform to the wiring instructions in this manual.

---

##### 2.4.1 Installation Limitations

Those installing the JA10, on or in a specific type or class of aircraft, must determine that the aircraft installation conditions meet standards. The JA10 may be installed only by following the applicable airworthiness requirements.

##### 2.4.2 Cabling and Wiring

All wire shall be selected in accordance with the original aircraft manufacturer's maintenance instructions, or AC43.13-1B Change 1, Paragraphs 11-76 through 11-78. Unshielded wire types shall qualify to MIL-W-22759 as specified in AC43.13-1B Change 1, Paragraphs 11-85, 11-86, and listed in Table 11-11. For shielded wire applications, use Tefzel MIL-C-27500 shielded wire with tag ring or equivalent (for shield terminations) to make the most compact and easily terminated interconnect. Follow the Connector Map in Appendix A of this manual.



Allow 3" from the end of the shielded wiring to the shield termination to allow the connector hood to be easily installed. Refer to the Interconnect drawing in Appendix A of this manual for shield termination details. Note that this unit has a 'clamshell' hood that is installed after the wiring is complete.

Maintain wire segregation and route wiring in accordance with the original aircraft manufacturer's maintenance instructions.

Unless otherwise noted, all wiring shall be a minimum of 24 AWG, except power and ground lines, which shall be a minimum of 22 AWG. Refer to the Interconnect drawing for additional specifications. Check that the ground connection is clean and well secured, and that it shares no path with any electrically noisy aircraft accessories such as blowers, turn-and-bank instruments, or similar loads.

### 2.4.3 Mechanical Installation

The JA10-001 can be mounted in any attitude and location with adequate space for the front panel and sufficient clearance for the connector and wiring harness. It requires no direct cooling.



---

**Note:** During bench test set up, it is normal for the JA10-001 chassis to become warm to the touch.

---

### 2.4.4 In-Line PTT Cordsets

If in-line PTT cordsets (drop cords) are used, be aware that incorrectly configured or improperly shielded in-line PTT cordsets can lead to significant audio problems.

### 2.4.5 Legend Replacement

The JA10-001 illuminated legends are field replaceable. For further information, refer to the '[Legend Replacement](#)' document in Appendix A of this manual.

### 2.4.6 Post Installation Checks

#### 2.4.6.1 Voltage/Resistance checks.

Do not attach this unit until the following conditions are met:

- a) Check P1 pin **62** (chassis ground) for continuity to ground (less than 0.5  $\Omega$ ).
- b) Check P2 pin **22** for +28 Vdc relative to ground.
- c) Check P2 pin **43** for continuity to ground (less than 0.5  $\Omega$ ).
- d) Check P2 pins **11** thru **19**, **33**, **54** and **42** for continuity to ground (less than 0.5  $\Omega$ ) when the relevant switch is closed.
- e) Check P3 pins **10**, **11** and **19** for continuity to ground (less than 0.5  $\Omega$ ) when the relevant switch is closed.
- f) Check all pins for shorts to ground or adjacent pins.

#### 2.4.6.2 Configuration

Ensure that the JA10 contains the correct configuration settings. This may be done at the factory, on the maintenance bench or in the aircraft before the power on checks are performed. Refer to section 2.5.1.

#### 2.4.6.3 Power on Checks.

Power up the aircraft's systems and confirm normal operation of all functions of the JA10. Refer to Section 3 (Operation) for specific operational details.

- a) Begin with only the USER 1 headset attached. Confirm correct ICS and radio operation for both receive and transmit. Check yoke or cyclic switch action. Check the radio selection and inputs. Do not proceed until the radios are functioning correctly.
- b) If there is a music source in the system, turn it on and check for proper mute operation.
- c) Unusual buzzes, hums or other background audio are symptomatic of multiple grounds, or noisy external systems such as blowers or pumps sharing wiring with the audio system. If a transmitter fails to key or



correctly modulate it is often the result of not connecting all required grounds to the radio or external audio system.

- d) Check the Emergency operation.
- e) Plug in the USER 2 headset. Confirm radio operation for receive and transmit operation and check for correct ICS operation. Check yoke or cyclic switch functions.
- f) Plug in any remaining headsets, and check for correct ICS operation. Note that an incorrect cordset (drop cord) or improper jack wiring may cause a wide range of problems, from loss of audio to a tone heard in the headset.
- g) Check that all configurations settings are correct.

When all performance checks are satisfied, complete the necessary regulatory documentation before releasing the aircraft for service. Refer to [Appendix B](#).

## 2.5 Adjustments and Configuration using ProCS™

All the JA10-001 internal adjustments are set from the [Product Configuration Software ProCS™](#). Configuration data is sent to the JA10-001 via the front panel connector (J10) or via a maintenance configuration connector, using the Configuration Cables and a computer running the ProCS™ software. For configuration requirements, see section 2.5.1.

For full information on the configuration process, and for installation of ProCS™ on your computer, refer to the [ProCS™ manual](#) on the Jupiter Avionics website - [www.jupiteravionics.com/productsoftware](http://www.jupiteravionics.com/productsoftware).

### 2.5.1 Configuration Cabling Requirements

To configure the JA10-001, it is necessary to load the [Product Configuration Software ProCS™](#) onto a Windows-based computer as described in the [ProCS™ manual](#).

The cables required to configure the JA10-001 are not included with the unit.

#### **Cabling option 1:**

Quantity	Description	JA10-001
1	USB A to RS232 9-Pin Cable	CAB-USB-0002
1	Configuration Cable	JA99-001

#### **Cabling option 2:**

Quantity	Description	JA10-001
1	USB A Male to RS232 3.5mm Plug	CAB-USB-0006

### 2.5.2 ProCS™ Setup



The ProCS™ JA10-001 menu item 'ProCS Setup' provides Setup drawings showing the cabling arrangement for connecting the JA10-001 to a computer running the ProCS™.

### 2.5.3 Configurable Settings

A standard unit is shipped from the factory with all internal adjustments configured to the default levels. At installation, it may be desirable to change some of these settings to suit the local operating environment.



**Note:** To configure the JA10-001, power must be applied to the unit and the TX Select knob must be in any one of the COM1 to AUX positions..

Within ProCS™, the configurable settings are grouped together into the following sections:



### 2.5.3.1 Front Panel Switches

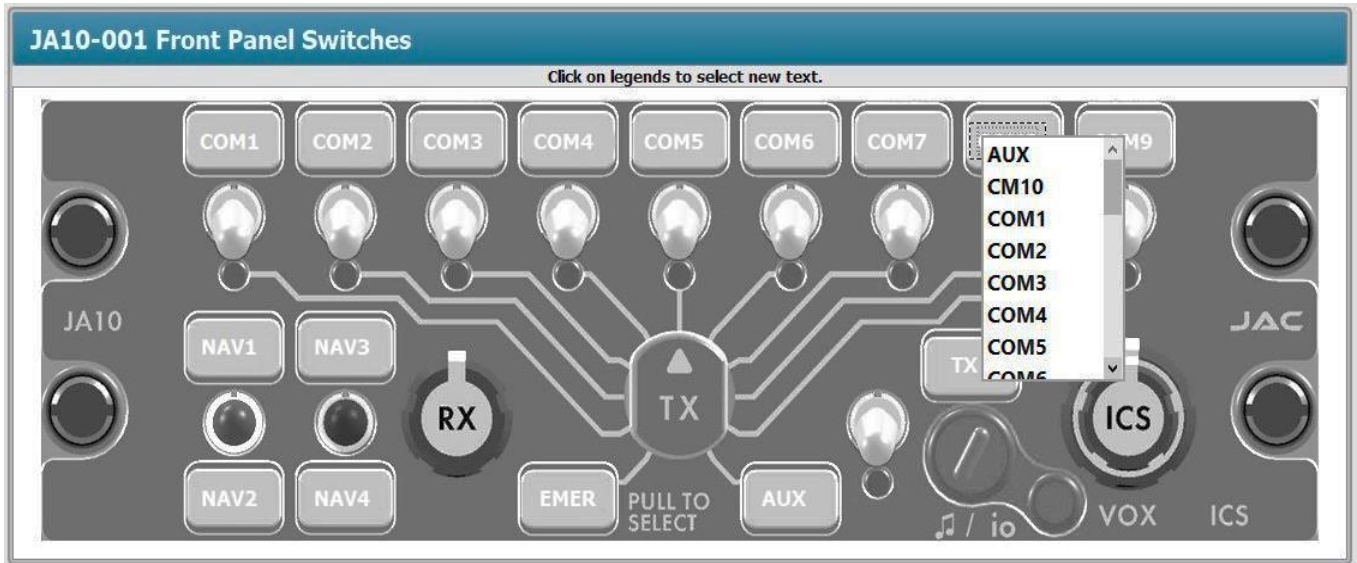

The Front Panel Switches window is used to specify the text for each legend.



**Note:** The legends support four character maximum names; thus COM 10 will be represented as CM10.

### 2.5.3.2 Virtual Front Panel (Test purposes only)



**Note:** The Virtual Front Panel window is used during testing.



2.5.3.3 **JA10-001 Radios**

### JA10-001 Radios

#### Radio Assignments

Transceivers   Receivers   Cockpit Voice Recorders   Radios List

COM1:	Default Transceiver [Rx Level = 7.75 Vrms, Tx Level = 0.250 Vrms]	▼
COM2:	Default Transceiver [Rx Level = 7.75 Vrms, Tx Level = 0.250 Vrms]	▼
COM3:	Default Transceiver [Rx Level = 7.75 Vrms, Tx Level = 0.250 Vrms]	▼
COM4:	Default Transceiver [Rx Level = 7.75 Vrms, Tx Level = 0.250 Vrms]	▼
COM5:	Default Transceiver [Rx Level = 7.75 Vrms, Tx Level = 0.250 Vrms]	▼
COM6:	Default Transceiver [Rx Level = 7.75 Vrms, Tx Level = 0.250 Vrms]	▼
COM7:	Default Transceiver [Rx Level = 7.75 Vrms, Tx Level = 0.250 Vrms]	▼
COM8:	Default Transceiver [Rx Level = 7.75 Vrms, Tx Level = 0.250 Vrms]	▼
COM9:	Default Transceiver [Rx Level = 7.75 Vrms, Tx Level = 0.250 Vrms]	▼
AUX:	Default Transceiver [Rx Level = 7.75 Vrms, Tx Level = 0.250 Vrms]	▼

The Radio Assignments window is used to define the radios for the transceivers, receivers and Cockpit Voice Recorder.

Refer to the ProCS™ manual for full information on radio selection.





2.5.3.4 **JA10-001 Receive Levels**

### JA10-001 Receive Levels

#### Input Levels

COM1:	Default Transceiver :	1.00 Vrms		10.00 Vrms	[7.75 Vrms]	Default Level
COM2:	Default Transceiver :	1.00 Vrms		10.00 Vrms	[7.75 Vrms]	Default Level
COM3:	Default Transceiver :	1.00 Vrms		10.00 Vrms	[7.75 Vrms]	Default Level
COM4:	Default Transceiver :	1.00 Vrms		10.00 Vrms	[7.75 Vrms]	Default Level
COM5:	Default Transceiver :	1.00 Vrms		10.00 Vrms	[7.75 Vrms]	Default Level
COM6:	Default Transceiver :	1.00 Vrms		10.00 Vrms	[7.75 Vrms]	Default Level
COM7:	Default Transceiver :	1.00 Vrms		10.00 Vrms	[7.75 Vrms]	Default Level
COM8:	Default Transceiver :	1.00 Vrms		10.00 Vrms	[7.75 Vrms]	Default Level
COM9:	Default Transceiver :	1.00 Vrms		10.00 Vrms	[7.75 Vrms]	Default Level
AUX:	Default Transceiver :	1.00 Vrms		10.00 Vrms	[7.75 Vrms]	Default Level
NAV1:	Default Receiver :	1.00 Vrms		10.00 Vrms	[7.75 Vrms]	Default Level
NAV2:	Default Receiver :	1.00 Vrms		10.00 Vrms	[7.75 Vrms]	Default Level
NAV3:	Default Receiver :	1.00 Vrms		10.00 Vrms	[7.75 Vrms]	Default Level
NAV4:	Default Receiver :	1.00 Vrms		10.00 Vrms	[7.75 Vrms]	Default Level
DIRECT1:	Default Receiver :	1.00 Vrms		10.00 Vrms	[7.75 Vrms]	Default Level
DIRECT2:	Default Receiver :	1.00 Vrms		10.00 Vrms	[7.75 Vrms]	Default Level
DIRECT3:	Default Receiver :	1.00 Vrms		10.00 Vrms	[7.75 Vrms]	Default Level
DIRECT4:	Default Receiver :	1.00 Vrms		10.00 Vrms	[7.75 Vrms]	Default Level

The receive and Direct Audio input level of each of COM 1-9, AUX, NAV 1-4 and DIRECT 1-4 inputs can be adjusted from 1 to 10 Vrms. (Default: 7.75)

#### Receive Audio Detector

0dB = Rated Input Level

The Receive Audio Detector threshold can be adjusted from -58 to -12 dB of rated input level. (Default: -25 dB)

USER1/2 Level: -46 dB -12 dB [-25 dB]

#### USER1 & USER2 Receive Composite Output

Rated Load Impedance = 600 Ohms

The USER1 & USER2 Receiver Composite Output levels can be adjusted from 0.25 to 2.50 Vrms. (Default: 1.00 Vrms)

USER1 Level: 0.25 Vrms 2.50 Vrms [1.00 Vrms]

USER2 Level: 0.25 Vrms 2.50 Vrms [1.00 Vrms]

#### USER1 & USER2 DIR RX Volume

Rated Load Impedance = 600 Ohms

The USER1 & USER2 DIR RX Volume can be adjusted from 1.00 to 10.00 Vrms. (Default: 7.75 Vrms)

USER1 Level: -30 dB 0 dB [0 dB]

USER2 Level: -30 dB 0 dB [0 dB]





2.5.3.5 **JA10-001 Transmit Levels**

### JA10-001 Transmit Levels

**Transmit Levels**  
**Rated Load Impedance = 150 Ohms**

The level of each of the ten Transceiver MIC output signals can be adjusted from 0.010 to 1.000 Vrms. **(Default: 0.250 Vrms)**

COM1:	Default Transceiver :	0.010 Vrms		1.000 Vrms	<b>[0.250 Vrms]</b>	<input type="button" value="Default Level"/>
COM2:	Default Transceiver :	0.010 Vrms		1.000 Vrms	<b>[0.250 Vrms]</b>	<input type="button" value="Default Level"/>
COM3:	Default Transceiver :	0.010 Vrms		1.000 Vrms	<b>[0.250 Vrms]</b>	<input type="button" value="Default Level"/>
COM4:	Default Transceiver :	0.010 Vrms		1.000 Vrms	<b>[0.250 Vrms]</b>	<input type="button" value="Default Level"/>
COM5:	Default Transceiver :	0.010 Vrms		1.000 Vrms	<b>[0.250 Vrms]</b>	<input type="button" value="Default Level"/>
COM6:	Default Transceiver :	0.010 Vrms		1.000 Vrms	<b>[0.250 Vrms]</b>	<input type="button" value="Default Level"/>
COM7:	Default Transceiver :	0.010 Vrms		1.000 Vrms	<b>[0.250 Vrms]</b>	<input type="button" value="Default Level"/>
COM8:	Default Transceiver :	0.010 Vrms		1.000 Vrms	<b>[0.250 Vrms]</b>	<input type="button" value="Default Level"/>
COM9:	Default Transceiver :	0.010 Vrms		1.000 Vrms	<b>[0.250 Vrms]</b>	<input type="button" value="Default Level"/>
AUX:	Default Transceiver :	0.010 Vrms		1.000 Vrms	<b>[0.250 Vrms]</b>	<input type="button" value="Default Level"/>

**Transmit Settings**

COM7 Duplex  
 COM8 Duplex  
 COM9 Duplex  
 AUX Duplex

Any or all of the COM 7 to COM 10 (AUX) radios can be selected as Duplex. Refer to [section 3.3.4](#).

2.5.3.6 **JA10-001 Sidetone Levels**

### JA10-001 Sidetone Levels

**Receive Sidetone Level**

The Receive Sidetone Level can be adjusted from -12 to 0 dB of the rated phone Level. **(Default -6 dB)**

USER1 COM1 thru COM6 RX input Level on PHN output:	0 dB		-12 dB	<b>[-6 dB]</b>
USER2 COM1 thru COM6 RX input Level on PHN output:	0 dB		-12 dB	<b>[-6 dB]</b>

**Artificial Sidetone Level**  
**0dB = Rated Phone Level**

The Artificial Sidetone Level output on the phones audio can be adjusted from -40 to 0 dB. **(Default -6 dB)**

USER1 MIC output signal Level on PHN output:	0 dB		-30 dB	<b>[-10 dB]</b>
USER2 MIC output signal Level on PHN output:	0 dB		-30 dB	<b>[-10 dB]</b>

**Artificial Sidetone Enable**

COM7 Artificial Sidetone Enable  
 COM8 Artificial Sidetone Enable  
 COM9 Artificial Sidetone Enable  
 AUX Artificial Sidetone Enable

Artificial Sidetone Enable can be selected for any or all of the COM 7 to COM 10 radios.

**Note: When Artificial Sidetone is enabled for a radio, that radio is deselected from the Receive Sidetone levels.**



2.5.3.7 **JA10-001 User Settings**

**JA10-001 User Settings**

Passengers may be allowed to listen to Receive Audio, and assigned to either USER 1 or USER 2's Controls.

**Passenger Settings**

Passengers Listen to Receive Audio

USER3 to USER8 (Passengers) Assignment:  Passengers Assigned to USER1's Controls  Passengers Assigned to USER2's Controls

Headset Impedance:  Low Impedance Headsets for All Users  High Impedance Headsets for All Users

2.5.3.8 **JA10-001 Connector Pin Configuration**

Several of the connector pins can be configured to meet the requirements of specific installations.  
Refer to the JA10-001 [Interconnect](#).

**JA10-001 Connector Pin Configuration**

**J3 Contacts Selection**

Pin 5:  USER1 RESET OUTPUT  USER1 RESET INPUT

Pin 18:  USER1 ICS ISOLATE MODE  USER2 ICS ISOLATE MODE  CREW ICS ISOLATE MODE

Pin 23:  USER2 RESET OUTPUT  USER2 RESET INPUT



**Note:** The JA10-001 may be configured to allow USER 1 ICS Isolate, USER 2 ICS Isolate, or Crew (USER 1 and USER 2) ICS Isolate.

2.5.3.9 **JA10-001 Audio Muting (During Transmit)**

When the Mute RX Audio check box is checked the Receive Audio is muted during transmit (**Default: unchecked**)

When the Mute ICS Audio check box is checked the ICS Audio is muted during transmit (**Default: unchecked**)

The Mute Music Audio check box is checked and Music Audio is always muted during transmit.

**JA10-001 Audio Muting**

**Audio Muting During Transmit**

Mute Rx Audio

Mute ICS Audio

Mute Music Audio (Note: always enabled)



2.5.3.10 **JA10-001 CVR Level**

### JA10-001 CVR Level

The level of the Cockpit Voice Recorder audio for each USER may be adjusted from 0.01 to 1 Vrms. (**Default: 0.50 Vrms**)

#### USER1 CVR Audio Output Levels

**Rated Load Impedance = 5 kOhms**

Receive Only	Default CVR :	0.010 Vrms		1.000 Vrms	<b>[0.500 Vrms]</b>	<input type="button" value="Default Level"/>
USER1 Mic Only	Default CVR :	0.020 Vrms		2.000 Vrms	<b>[1.000 Vrms]</b>	
Music Only	Default CVR :	0.005 Vrms		0.500 Vrms	<b>[0.250 Vrms]</b>	

**Note:**

1. All Inputs at rated level.
2. Where applicable, rated level on phones output.

#### USER2 CVR Audio Output Levels

**Rated Load Impedance = 5 kOhms**

Receive Only	Default CVR :	0.010 Vrms		1.000 Vrms	<b>[0.500 Vrms]</b>	<input type="button" value="Default Level"/>
USER2 Mic Only	Default CVR :	0.020 Vrms		2.000 Vrms	<b>[1.000 Vrms]</b>	
Music Only	Default CVR :	0.005 Vrms		0.500 Vrms	<b>[0.250 Vrms]</b>	

**Note:**

1. All Inputs at rated level.
2. Where applicable, rated level on phones output.

2.5.3.11 **JA10-001 Music Levels**

### JA10-001 Music Levels

The music output level of the two Music input signals to the Phones audio can be adjusted from -40 to 0 dB of rated phone level (**Default: 0 dB**).

#### USER1 Music Output Level

**0dB = Rated Phone Level**

Output Level:	-40 dB		0 dB	<b>[0 dB]</b>
Attenuation Level (During Mute Function):	0 dB		-40 dB	<b>[-40 dB]</b>

The attenuation level during muting of the music signal can be adjusted from -40 to 0 dB (**Default: -40 dB**).

#### USER2 Music Output Level

**0dB = Rated Phone Level**

Output Level:	-40 dB		0 dB	<b>[0 dB]</b>
Attenuation Level (During Mute Function):	0 dB		-40 dB	<b>[-40 dB]</b>

#### Music Input Level

The music input level cannot be adjusted.

Music Left (Front Panel & Rear Connector):	0.00 Vrms		0.00 Vrms	<b>[0.00 Vrms]</b>
Music Right (Front Panel & Rear Connector):	0.00 Vrms		0.00 Vrms	<b>[0.00 Vrms]</b>



### 2.5.3.12 JA10-001 ICS Tie Line

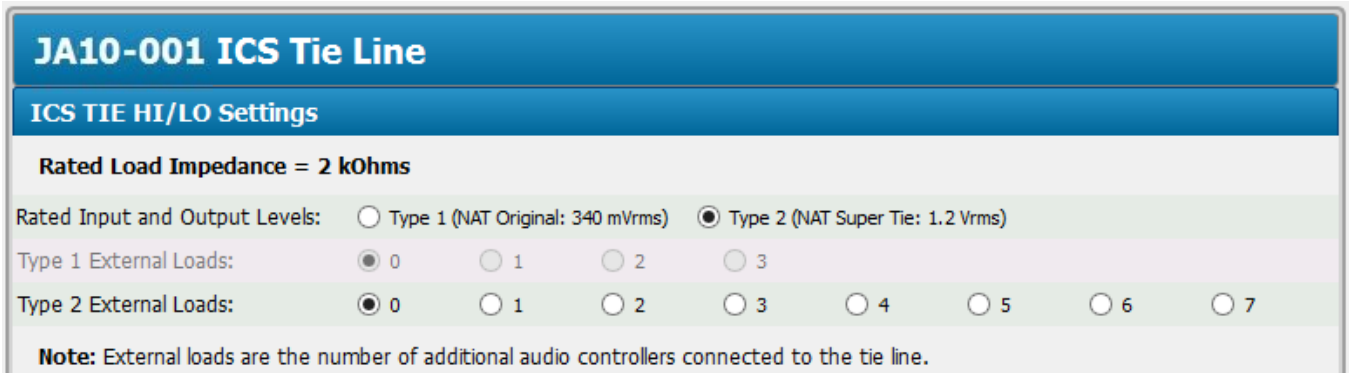

The rated input and output levels of the intercom tie line can be selected as Type 1 or Type 2 (**Default: Type 2**).

The quantity of external loads for a type1 intercom tie line can be selected from 0 to 3 (**Default: 0**).

The quantity of external loads for a type 2 intercom tie line can be selected from 0 to 7 (**Default: 0**).

### 2.5.3.13 JA10-001 VOX

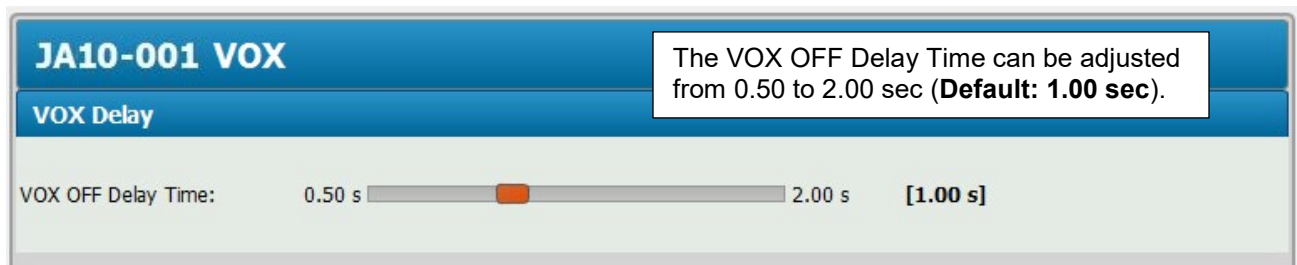

### 2.5.3.14 JA10-001 Connector Maps

The Connector Maps section is used to generate custom Connector Maps and Interconnects for use by the installing agency.

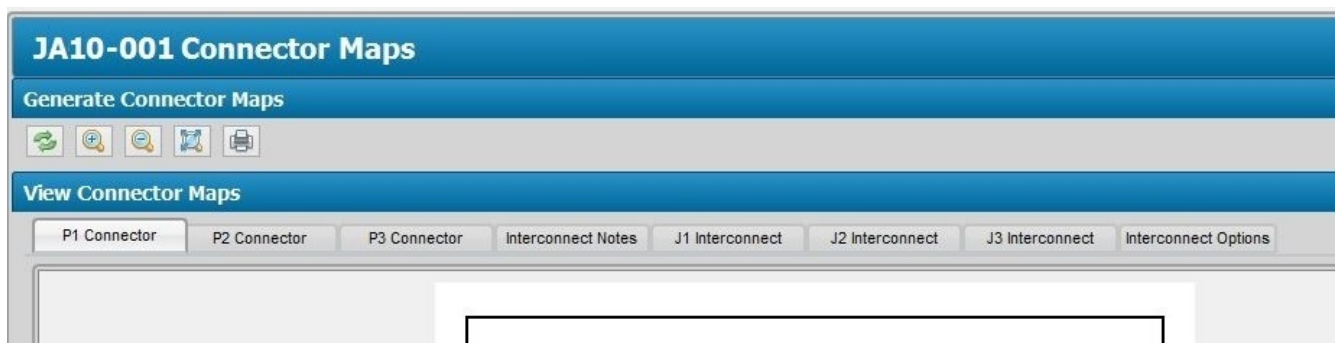

### 2.5.4 Other Configuration Features

In the JA10-001 Product Information Window, the model number, serial number, MOD status and check sum of the JA10-001 audio panel can be stored and viewed.



## **2.6 Installation Kit**

The kit required to install this unit is not included with the unit.

The installation kit (Part # INST-JA10) consists of the following:

<b>Quantity</b>	<b>Description</b>	<b>JA10-001</b>
88	Machined 22 AWG - Mil Spec, D-Submin - Crimp Socket	CON-3320-0354
1	62 pin D-sub connector with hood and crimp sockets,	CON-3430-0062
1	26 pin, D-Subminiature - High Density - Crimp Socket Housing	CON-3470-0026
1	62 pin D-Subminiature - High Density - Crimp Socket Housing	CON-3470-0062
2	D-Sub 4-40 , Hardware - Jack Screws	CON-5150-0440
1	15 Pin Clamshell, Hardware - Plastic D-Sub Hoods	CON-5300-0115
1	37 Pin Clamshell, Hardware - Plastic D-Sub Hoods	CON-5300-0137
1	0.375" Inside Diameter, Hardware - Tag Ring	CON-5500-0375
2	0.625" Inside Diameter, Hardware - Tag Ring	CON-5500-0625
2	1" Inside Diameter, Heat Shrink Tube	WIR-HTSK-1000
1	3/4" Inside Diameter - Black, Heat Shrink Tube	WIR-HTSK-0750

### **2.6.1 Recommended Crimp Tools**

<b>Standard D-Sub Crimp Tool Chart</b>			
<b>Tool Type</b>	<b>Hand crimping tool</b>	<b>Positioner</b>	<b>Insertion/extractor tool</b>
POSITRONIC	9507-0-0-0	9502-5-0-0	4711-2-0-0
DANIELS	AFM 8	K13-1	91067-2
MIL-SPEC	M22520/2-01	M22520/2-08	M81969/1-02

## **2.7 Installation Drawings**

The drawings and documents required for Installation can be found in [Appendix A](#) of this manual.

### **2.7.1 Generation of Custom Drawings**

The interconnects and connector maps in Appendix A of this manual are generic drawings based on the standard version of the JA10-001. However, if a unit has been configured using ProCS™ software to change switch legends or lighting voltages, the software can be used to generate fully customized interconnects and connector maps for use by the installer.





## JA10-001 Audio Controller - Ten Transceiver

### SECTION 3 – OPERATION

#### 3.1 Introduction

This section contains the operating instructions for the JA10-001.



**Note:** The JA10-001 USER 2 controls are on an optional separate remote control panel, and can be found in the JCP3-x01 manual.

#### 3.2 USER 1 Front Panel Controls



**Note:** The legends and deadfront annunciator may be ordered with custom markings. The controls will be referred to by the default legend and annunciator names as shown below.

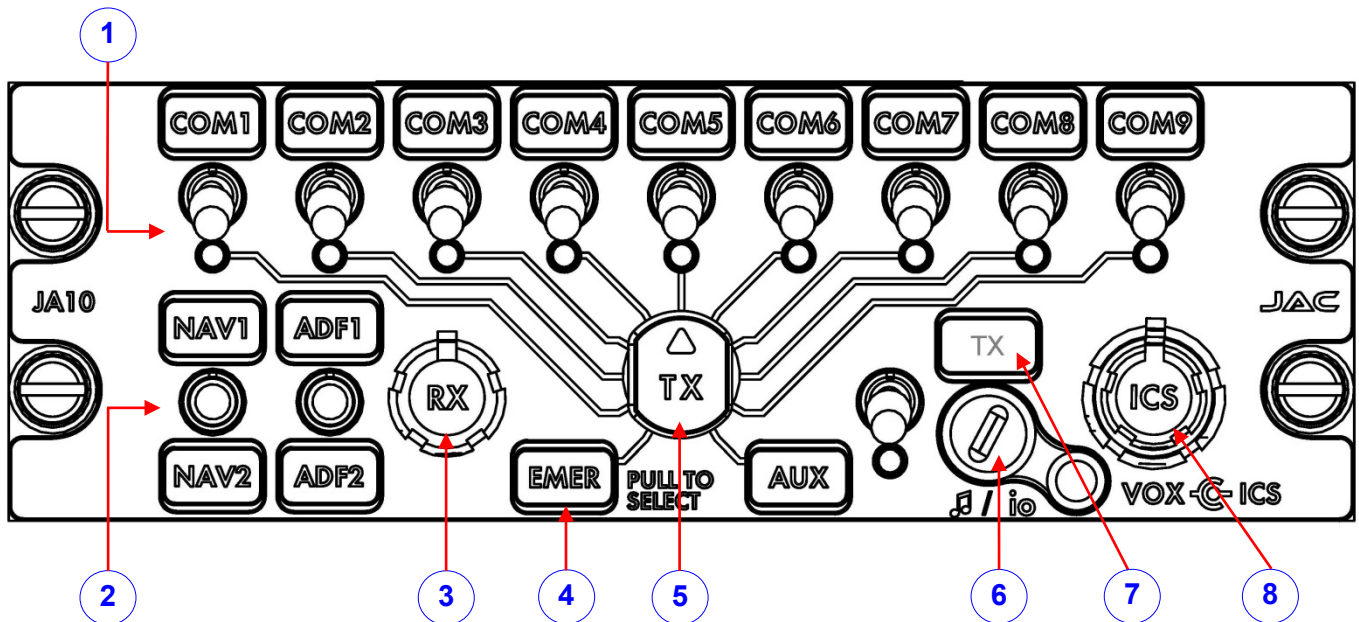

1. Transceiver receive audio select switches, TX select annunciators and associated legends
2. Receiver audio select switches and associated legends
3. Receive volume control
4. EMER legend
5. Transmit and Emergency mode selector
6. Music/configuration input connector
7. Transmit annunciator (deadfront)
8. VOX/ICS volume control



**(1)** Transceiver receive audio select switches, TX select annunciators and associated legends

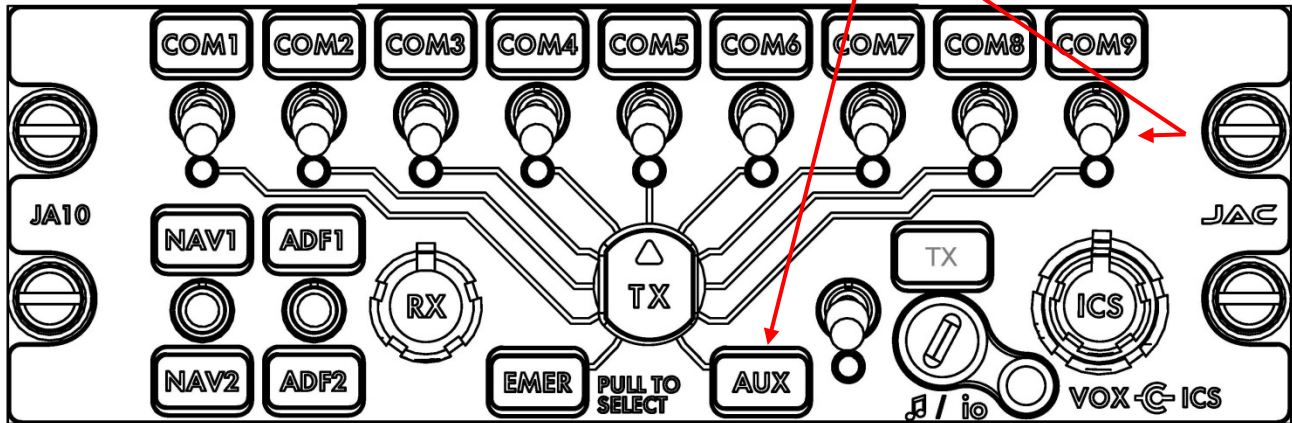

These are ten white two-position toggle switches positioned round the TX selector control (5).

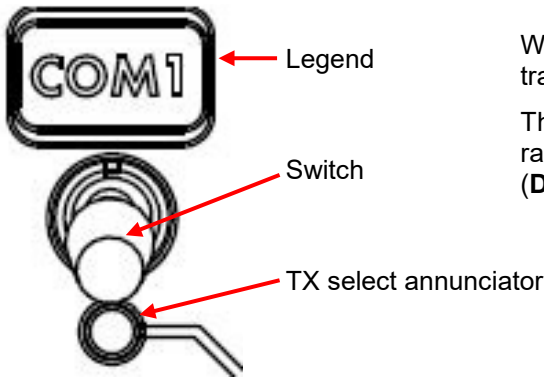

When a switch is set to the 'up' position audio from the associated transceiver is routed to the phones.

The legends may be ordered with custom markings to match aircraft radio nomenclature.  
(Default – COM1 to COM9, and AUX.)

**(2)** Receiver audio select switches and associated legends

These are two blue three-position centre-off toggle switches. When the switch is set to the 'up' or 'down' position towards a legend, audio from the selected receiver is routed to the phones.

The legends may be ordered with custom markings to match aircraft radio nomenclature.  
(Default – NAV1, NAV2, ADF1 and ADF2.)

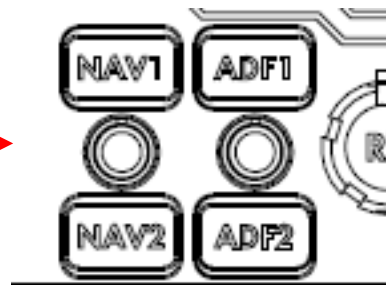

**(3)** Receive Volume Control

This is a rotary knob that adjusts the phones volume of the receive audio from minimum (rotated fully counterclockwise - CCW) to maximum (rotated fully clockwise - CW). Individual radio volume controls should be set to a nominal level, and then adjusted for changing flight conditions using this control.

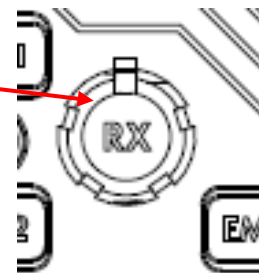



**(4) EMER Legend**

The **EMER** (Emergency) legend marks the Emergency position of the Transmit selector (5).

To select emergency mode, the control must be pulled and turned to the **EMER** position.

For full information on Emergency and Normal Mode operation, see [sections 3.3](#) and [3.6](#) below.

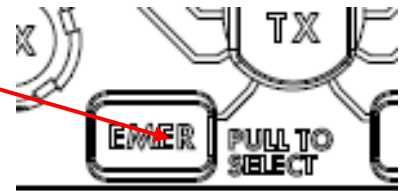

**(5) USER 1 Transmit and Emergency mode Selector**

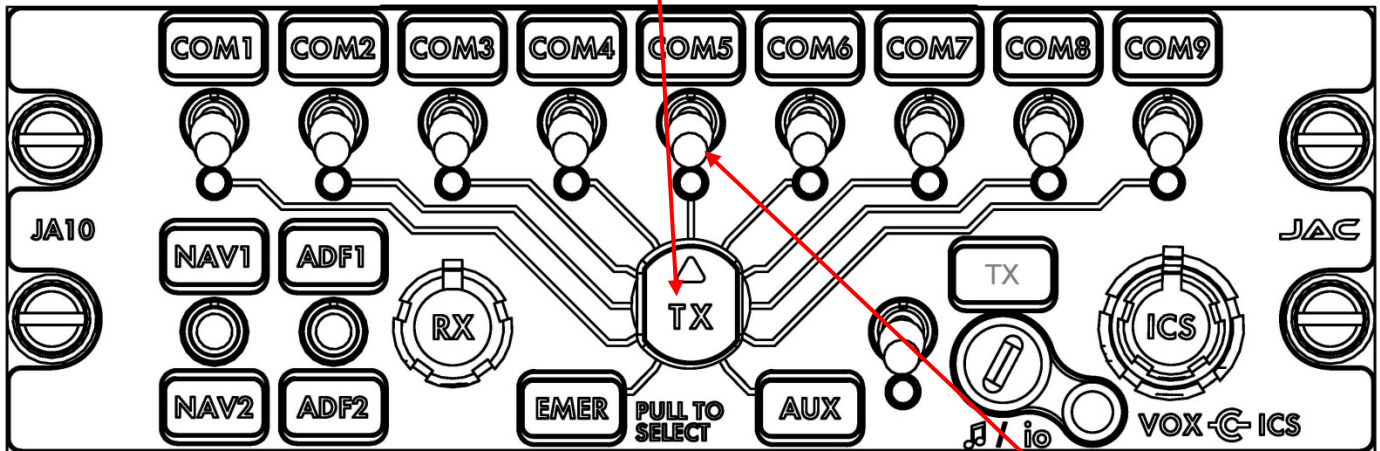

This is a rotary eleven-position control that is used to select transmission via one of the transceivers.

The appropriate annunciator will light green to show which transceiver is selected for transmit - '**COM5**' in this example.

Each of the transmit selector positions is linked by a white line to the corresponding transmit select annunciators, transceiver switches and legends – **Default - COM1** through **COM9** and **AUX**. Position one (the furthest counter-clockwise position) selects Emergency mode (**EMER**). To select emergency mode, the control must be pulled and turned to the **EMER** position. When in the **EMER** position all transmit select annunciators are unlit.

**(6) Music/Configuration Connector (♫/io)**



This is a music input that is compatible with most music players. It accepts a 3 pole 3.5mm stereo plug with a slim diameter connector housing.

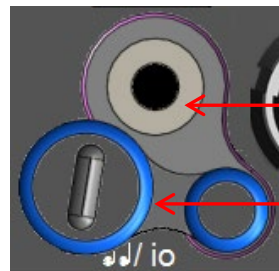

♫/io Port

Port Cover

The port (♫/io) is protected by a flexible cover, which can be lifted upwards or rotated round (as shown) to provide access to the port.

(This connector is also used during installation to change configuration settings.)



**CAUTION:** Attempting to connect an incompatible plug or device could damage the unit, the attached device, or both. In doubt, check with your installing agency.



### (7) USER 1 TX Annunciator

This is a deadfront legend that illuminates when USER 1 is transmitting.

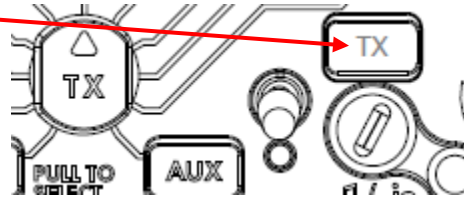

### (8) VOX/ICS Threshold Control



This is an unlit dual rotary control that adjusts the VOX level (the larger, bottom knob) and the ICS volume (the smaller, upper knob marked ICS).

The levels can be adjusted individually. Rotating the knobs clockwise (cw) will increase the level, and counterclockwise (ccw) will reduce it

Individual radio volume controls should be set to a nominal level, and then adjusted for changing flight conditions using this control.

Faceplate markings



To adjust for **VOX** (Voice activated) level, the VOX control should be set fully ccw (almost live) and then slowly rotated cw to the point where no intercom audio can be heard. The VOX control should be adjusted for proper operation according to the ambient noise.

## 3.3 USER 1 Normal Operation Mode



**Note:** Numbers in parentheses refer to the front panel controls shown in section 3.2.

The JA10-001 is in Normal mode when the front panel TX selector (5) is in any of the **COM 1** through **COM 9** or **AUX** positions (not **EMER**) and suitable electrical power is supplied to the unit.

### 3.3.1 Panel Lighting

The legends and annunciators will be illuminated (when appropriate) and dim through the aircraft lighting buss.

### 3.3.2 Receiving

When the JA10-001 receives an incoming transmission on a transceiver or receiver that has been selected, either by the white transceiver receive switches (1) or the transmit selector (5), the incoming audio will be directed to the USER 1 phones.

The audio level of any incoming transmission will be muted if the unit is transmitting and muting of receive audio during transmit is enabled.

### 3.3.3 Transmitting (Transmit Operation)

To select a transceiver, rotate the TX (transmit select) until it aligns with the line leading to the Transceiver Select switch legend (see (1)) - default legends **COM 1** through **COM 9** or **AUX**. The corresponding Transmit Select annunciator will illuminate.

When the USER 1 TX PTT is activated, the unit will transmit on the selected transceiver, and the deadfront Transmit Annunciator (7) will illuminate 'TX'. Sidetone audio will be routed to the USER 1 phones, and any music will be muted for the duration of the transmission.



### 3.3.4 Duplex Operation



**Note:** The COM 7, COM 8, COM 9 and AUX transceivers may be configured as duplex, and used with a cellphone or sat-phone. Check your configuration with the installing agency.

---

If the unit has been configured for cellphone or sat-phone use and one of the configured COMs has been selected for transmit, momentarily activating the TX PTT will keep the transceiver transmitting. A second momentary activation of the TX PTT, or moving the Transmit Selector away from that transceiver, will stop the transmission.

### 3.3.5 VOX Operation

USER 1 MIC audio is routed to the ICS when the MIC audio level exceeds the VOX threshold.

USER 1 MIC audio is disconnected from the ICS when the MIC audio level falls below the VOX threshold for 0.5 to 2 seconds.

### 3.3.6 ICS Operation

ICS audio is the sum of all the MIC audio from users with ICS KEY active or with MIC audio level exceeding the VOX Threshold level.

The ICS audio also includes the audio input on the ICS TIE from other audio controllers.

The ICS audio is output on the phones of each user.

The ICS audio is muted during transmit.

The ICS audio level at the phones is controlled by the ICS volume control **(9)**.

### 3.3.7 ICS Isolate Operation

The JA10-001 can be connected to an external ICS ISOLATE switch that will isolate the USER 1 and / or USER 2 from the USER 3 to 8 ICS audio.



**Note:** The JA10-001 ICS Isolate mode is configured by the ProCS and there are three modes. Check your configuration with the installing agency.

---

If the JA10-001 has been configured in **USER 1** ICS Isolate mode and ICS ISOLATE is enabled, the USER 1 headset is removed from the ICS tie line.

If the JA10-001 has been configured in **USER 2** ICS Isolate mode and ICS ISOLATE is enabled, the USER 2 headset is removed from the ICS tie line.

If the JA10-001 has been configured is in **CREW** ICS Isolate mode and ICS ISOLATE is enabled, the USER 1 and USER 2 headsets are removed from the ICS tie line and connected together to allow a private intercom.

### 3.3.8 Music Operation

Any music to the phones will be muted by incoming audio (ICS, Receive or Direct Audio) or if the unit is transmitting. When the incoming audio has ended, the music will gradually return to the previous level.



---

### **3.4 USER 2 Normal Operation Mode**



**Note:** All USER 2 operation is per the applicable control device.

---

### **3.5 USER 3 to 8 Normal Operation Mode**



**Note:** USER 3 to USER 8 are configured to operate by the USER 1 controls (default) or the USER 2 controls as selected through ProCS™. Check your configuration with the installing agency.

---

#### **3.5.1 Receive Audio**

USER 3 to 8 will hear the receiver audio as selected and level controlled (RX) by either the USER 1 or USER 2, as configured by ProCS™.

#### **3.5.2 Direct Audio**

USER 3 to 8 will hear the direct audio sources as configured by ProCS™.

#### **3.5.3 Transmitting (Transmit Operation)**

USER 3 & 4 (designated at installation) will transmit on the transceiver selected by either the USER 1 or USER 2, as configured by ProCS™.

#### **3.5.4 ICS Operation**

USER 3 to 8 will hear the intercom audio as level controlled (ICS) and VOX control (VOX) by either the USER 1 or USER 2, as configured by ProCS™.

#### **3.5.5 ICS Isolation**

USER 3 to 8, when ICS Isolation mode is active, will hear the intercom audio from either only USER 1 & 3 to 8, or only USER 2 to 8, or only USER 3 to 8, as configured by ProCS™.

#### **3.5.6 Music Operation**

USER 3 to 8 will hear the music audio as via either the USER 1 or USER 2 music inputs, as configured by ProCS™.

### **3.6 Emergency Operation Mode**

The JA10-001 is in emergency mode when aircraft electrical power is lost or if Emergency Mode has been selected on the JA10-001 Front Panel TX and EMER Select switch, the optional control device EMERGENCY/NORMAL select switch, or the optional external EMERGENCY/NORMAL select switch.

#### **3.6.1 Auto Emergency Mode**

If the unit is in emergency mode because power has been lost to the unit, the sum of the COM 1 transceiver, NAV 1 receiver, and DIRECT 1 to 4 is routed to the USER 1 PHONES and USER 1 CVR. The USER 1 MIC and USER 1 TX PTT key are connected to the COM 1 transceiver.

The sum of the COM 2 transceiver, NAV 2 receiver, and DIRECT 1 to 4 is routed to the USER 2 PHONES and USER 2 CVR. The USER 2 MIC and USER 2 TX PTT key are connected to the COM 2 transceiver.

No other functions in the JA10-001 will operate when power is lost.



### 3.6.2 Selected Emergency Mode

If Emergency mode has been selected from the control device or from an external emergency/normal switch, and sufficient power is applied to the JA10-001, the JA10-001 is considered to be in Selected Emergency Mode.

In Selected Emergency Mode the sum of the COM 1 receive, NAV 1 receive, DIRECT 1 to 4 and MESSAGE audio is routed to the USER 1 PHONES and the USER 1 CVR. The USER 1 MIC and USER 1 TX PTT are connected to the COM 1 transceiver. USER 1 is disconnected from the ICS.

In Selected Emergency Mode, the sum of the COM 2 receive, NAV 2 receive, DIRECT 1 to 4 and MESSAGE audio is routed to the USER 2 PHONES and USER 2 CVR. The USER 2 MIC and USER 1 TX PTT are connected to the COM 2 transceiver. USER 2 is disconnected from the ICS. The COM 2 transceiver and NAV 2 receiver.

The COM 1 and COM 2 transceiver, NAV 1 and NAV 2 receiver and DIRECT 1 to 4 are not available to the USER 3 to 8. All other functions of the JA10-001 will operate.



# Installation and Operating Manual

## Appendix A - Installation Drawings

### A1 Introduction

The drawings necessary for installation and troubleshooting of the JA10-001 Audio Controller - Ten Transceiver are in this Appendix, as listed below.



**Note:** A fully customized set of Connector Maps and Interconnects can be created using the ProCS software. Refer to the [ProCS™ manual](#) for further information.

### A2 Installation Drawings

DOCUMENT	Rev
<a href="#">JA10-001 Connector Map</a>	A
<a href="#">JA10-001 Interconnect</a>	B
<a href="#">JA10-001 Mechanical Installation</a>	A
<a href="#">JA10-001 Equipment Block Diagram</a>	A

Reference Documents	
<a href="#">TOL-CUST-EXTR Legend Replacement</a>	A

# RECEIVE CONNECTOR

P1

62 PIN FEMALE DMIN  
MATING CONNECTOR

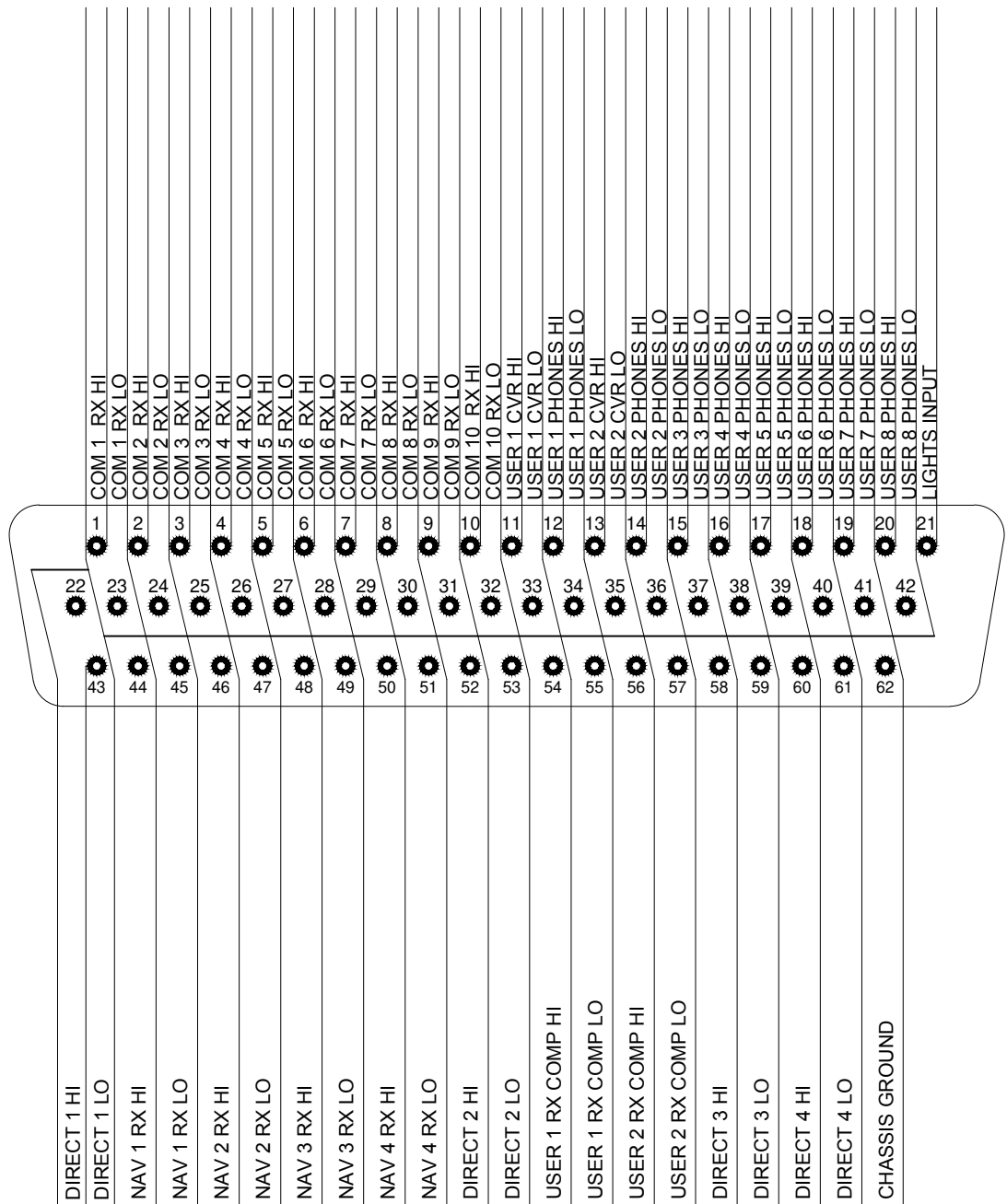

VIEW IS FROM REAR OF MATING CONNECTOR

PREPARED	KV	<b>JUPITER AVIONICS</b> CORPORATION		
CHECKED				
APPROVED		TITLE Audio Controller - Ten Transceiver P1 - Receive Connector		
CONFIDENTIAL & PROPRIETARY TO JUPITER AVIONICS CORP.		NCAGE CODE	PART NO.	SHEET
		L00N3	JA10-001	1/5
		DOC NO. JA10-001 Connector Map Rev A		



# TRANSMIT CONNECTOR

P2

62 PIN FEMALE DMIN  
MATING CONNECTOR

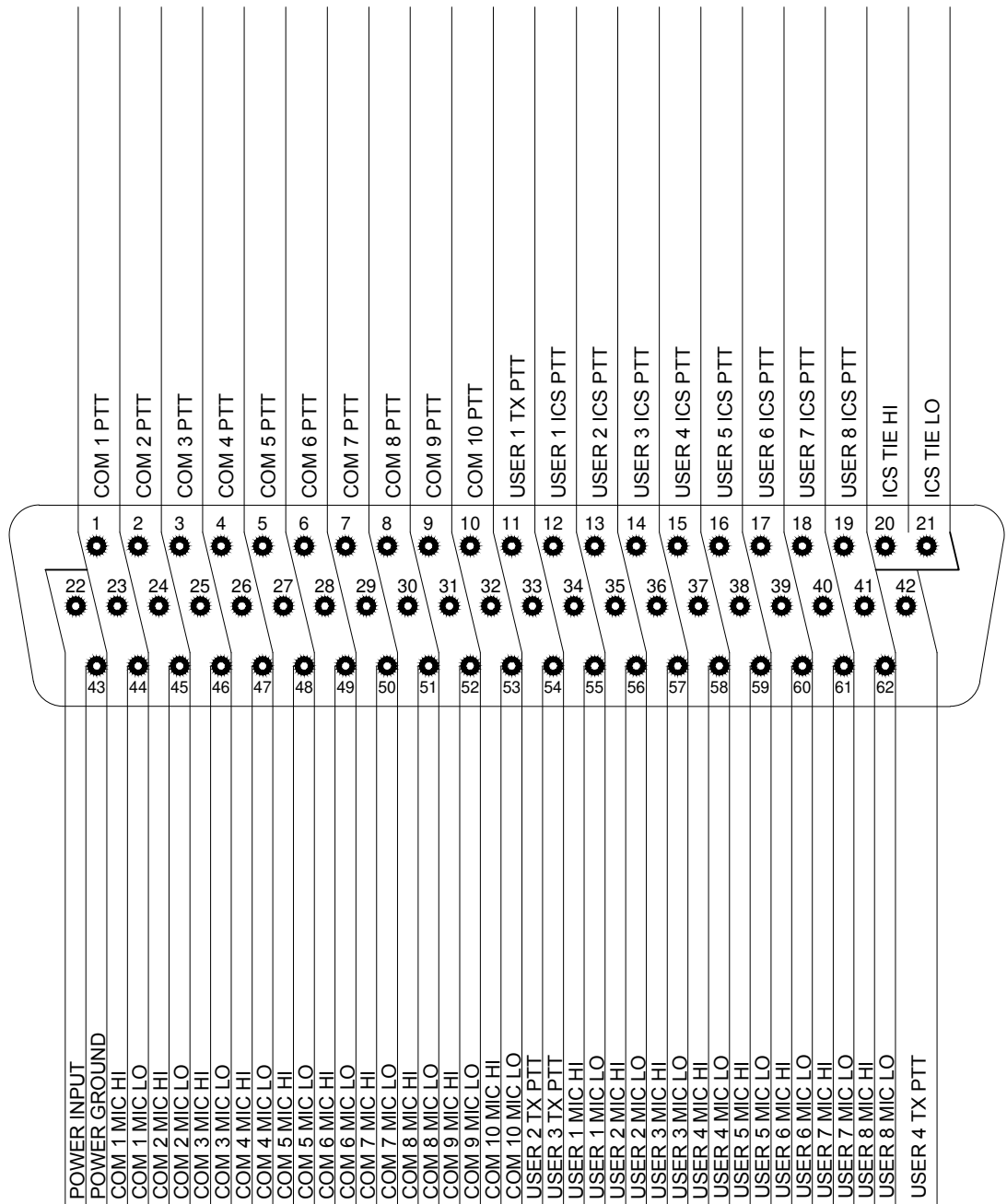

VIEW IS FROM REAR OF MATING CONNECTOR

PREPARED	KV	 <b>JUPITER AVIONICS</b> CORPORATION		
CHECKED				
APPROVED		NCAGE CODE <b>L00N3</b>	PART NO. JA10-001	SHEET 2/5
CONFIDENTIAL & PROPRIETARY TO JUPITER AVIONICS CORP.		DOC NO. JA10-001 Connector Map Rev A		

# CONTROL CONNECTOR

P3  
 26 PIN FEMALE DMIN  
 MATING CONNECTOR

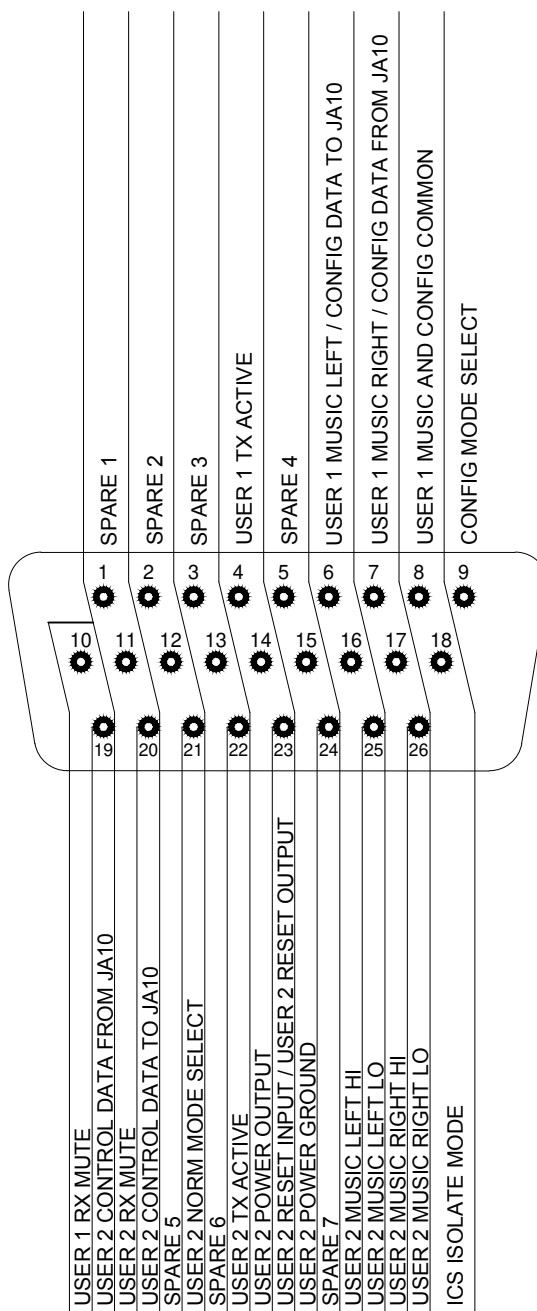

VIEW IS FROM REAR OF MATING CONNECTOR

PREPARED	KV	<b>JUPITER AVIONICS</b> <small>CORPORATION</small>		
CHECKED		TITLE Audio Controller - Ten Transceiver P3 - Control Connector		
APPROVED		NCAGE CODE <b>L00N3</b>	PART NO. JA10-001	SHEET 3/5
CONFIDENTIAL & PROPRIETARY TO JUPITER AVIONICS CORP.		DOC NO. JA10-001 Connector Map Rev A		

# CHASSIS GROUND CONNECTOR

P4 CHASSIS GROUND CONNECTOR

#4 RING TERMINAL  
MATING CONECTOR

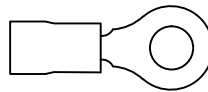

PREPARED	KV	 <b>JUPITER AVIONICS</b> CORPORATION		
CHECKED				
APPROVED		NCAGE CODE L00N3	PART NO. JA10-001	SHEET 4/5
CONFIDENTIAL & PROPRIETARY TO JUPITER AVIONICS CORP.		DOC NO. JA10-001 Connector Map Rev A		

## MUSIC / CONFIGURATION CONNECTOR

P5

ACCEPTS THE FOLLOWING PLUG FORMATS

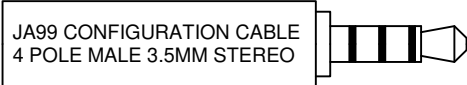

MATING PLUG NAMES

TIP: TX DATA  
1ST RING: RX DATA  
2ND RING: GROUND  
3RD RING: CONFIG AUDIO

UNIT SIGNAL NAMES

USER 1 MUSIC LEFT / CONFIG DATA TO JA10  
USER 1 MUSIC RIGHT / CONFIG DATA FROM JA10  
CONFIG COMMON  
CONFIG MODE SELECT

PREPARED	KV	 <b>JUPITER AVIONICS</b> CORPORATION		
CHECKED				
APPROVED		Audio Controller - Ten Transceiver P5 - Audio Configuration Connector		
CONFIDENTIAL & PROPRIETARY TO JUPITER AVIONICS CORP.		NCAGE CODE L00N3	PART NO. JA10-001	SHEET 5/5
		DOC NO. JA10-001 Connector Map Rev A		

JA10-001 INTERCONNECT WIRING NOTES



NOTES

1. ALL WIRE SIZE SHOULD BE 24 AWG MIN UNLESS OTHERWISE SPECIFIED. UNSHIELDED WIRE SHOULD BE SELECTED PER FAA AC43.13-1B CHANGE 1 PARA 11-76 TO 11-78. WIRE TYPES SHOULD BE IN ACCORDANCE WITH MIL-W-22759 AS DESCRIBED IN FAA AC43.13-1B CHANGE 1 PARA 11-85 AND 11-86 AND LISTED IN TABLE 11-11 OR 11-12. ALL SHIELDED CABLE SHOULD BE IN ACCORDANCE WITH MIL-DTL-27500 (REVISION H OR LATER).
2. CONNECTION TO AIRFRAME GROUND SHOULD BE MADE WITH 22 AWG WIRE UNLESS OTHERWISE SPECIFIED. LENGTH NOT TO EXCEED 3 FT (0.91 M).
3. CABLE SHIELDS AT THE CONNECTOR PINS SHOULD BE TERMINATED TO AIRFRAME GROUND USING A TAG RING P/N: MS27741-5 OR EQUIVALENT.
4. CONNECTOR PIN FUNCTION MAY BE CONFIGURED AS
  - a. RESET OUTPUT PIN OUTPUTS A MOMENTARY GROUND WHEN USER 2 CONTROL DATA TO AUDIO IS INVALID. OUTPUT IS OPEN COLLECTOR.
  - b. RESET INPUT PIN RESETS USER 2 CONTROL CIRCUIT WHEN PIN IS GROUNDED MOMENTARILY.
5. IF NOT CONNECTED TO JCP CONTROL PANEL, GROUND PIN FOR NORMAL OPERATION OR LEAVE UNCONNECTED FOR EMERGENCY OPERATION.
6. TX ACTIVE PIN OUTPUTS A GROUND WHEN USER TX PTT IS ACTIVE. OUTPUT IS OPEN COLLECTOR.
7. CONNECTOR PIN FUNCTION MAY BE CONFIGURED TO ISOLATE FROM INTERCOM AUDIO EITHER USER 1 or USER 2 or BOTH.
8. GROUND PIN TO MUTE ALL RECEIVE AUDIO EXCEPT THE AUDIO FROM THE TRANSCEIVER SELECTED TO TRANSMIT.
9. CONNECTOR PIN FUNCTION MAY BE CONFIGURED AS +28 VDC OR +14 VDC OR +5 VDC LIGHTS INPUT VOLTAGE.
10. CONNECT THE USER 2 PHONES, MIC, TX & ICS KEY ONLY WHEN A CONTROL PANEL OR CONTROL DEVICE IS CONNECTED TO THE USER 2 CONTROL DATA.
11. OPTIONAL CONNECTION FOR EQUIPMENT NEEDING PROTECTION FROM RADIO TRANSMIT SIGNALS.

CONNECTOR PIN LEGENDS

LEGEND

SPARE	INTERNAL CIRCUITS MAY EXIST AND MAY BE ACTIVATED FOR FUTURE USE. NO EXTERNAL WIRE CONNECTION.
N/C	NO CONNECTION



PREPARED	TAT			
CHECKED				
APPROVED		Audio Controller - Ten Transceiver Interconnect Notes		SHEET
		NCAGE CODE	PART NO.	1/7
		L00N3	JA10-001	
CONFIDENTIAL & PROPRIETARY TO JUPITER AVIONICS CORP.		DOC NO. JA10-001 Interconnect Rev B.dwg		

JA10-001  
RECEIVE CONNECTOR

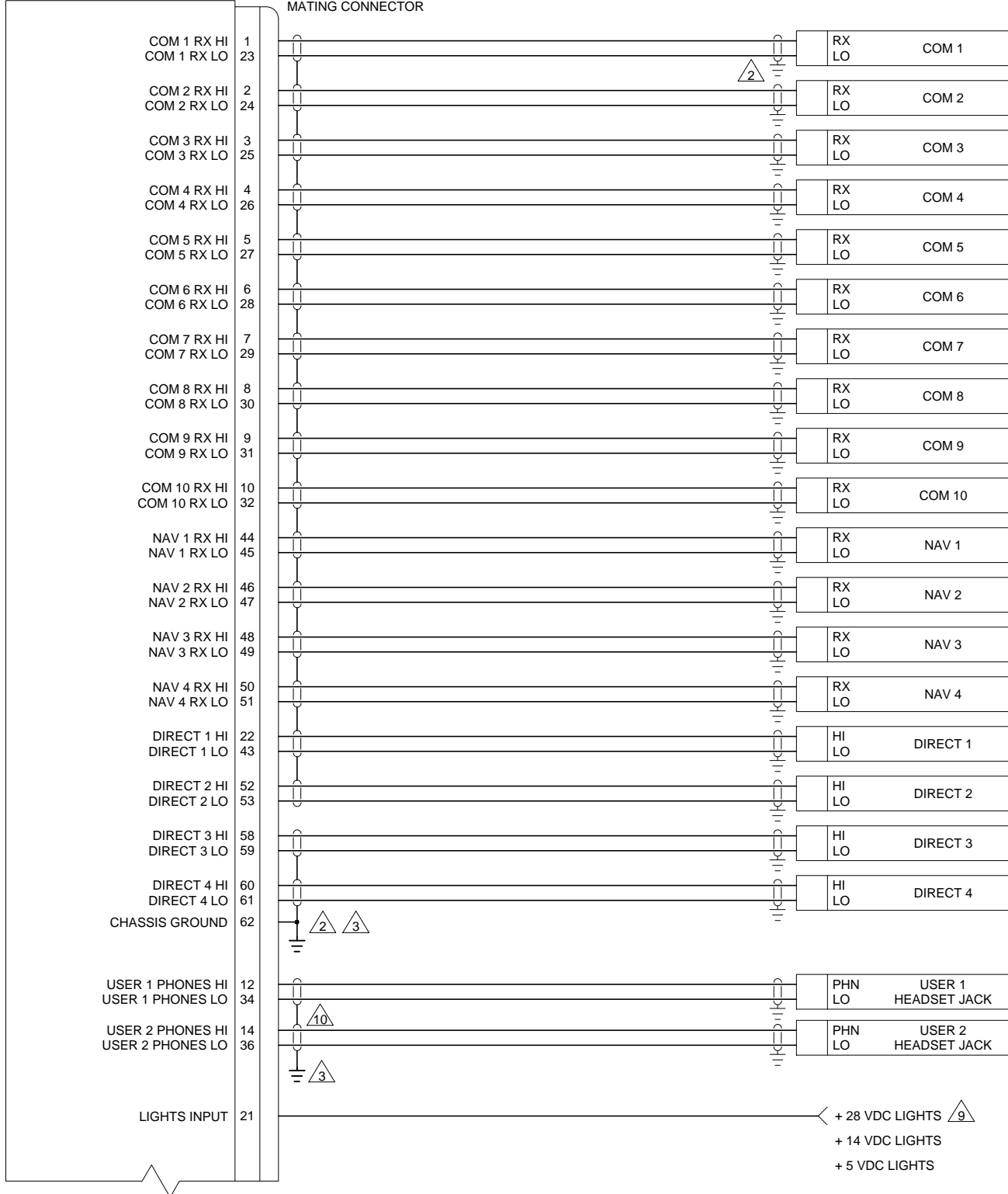

J1

P1  
62 PIN FEMALE DMIN  
MATING CONNECTOR



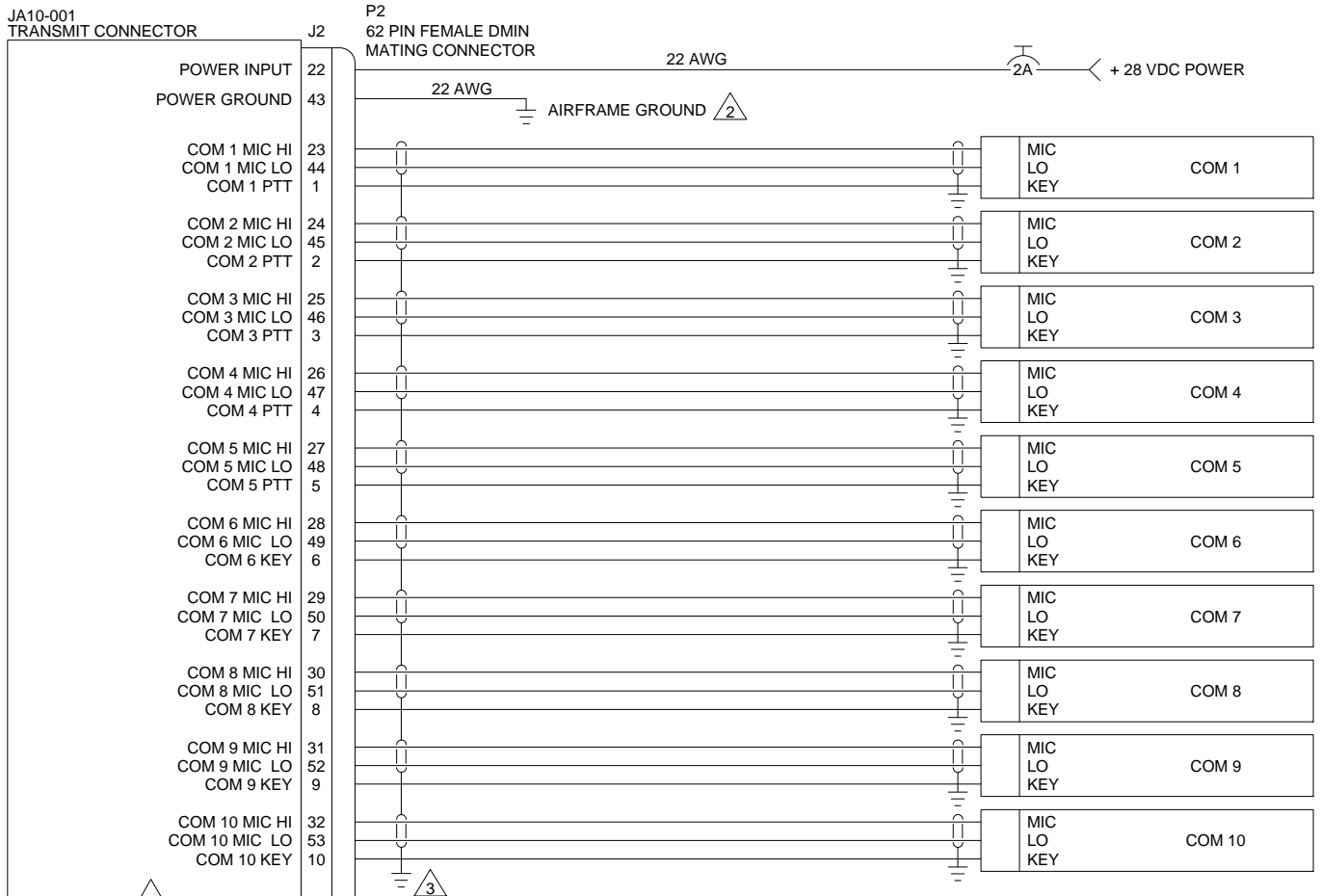
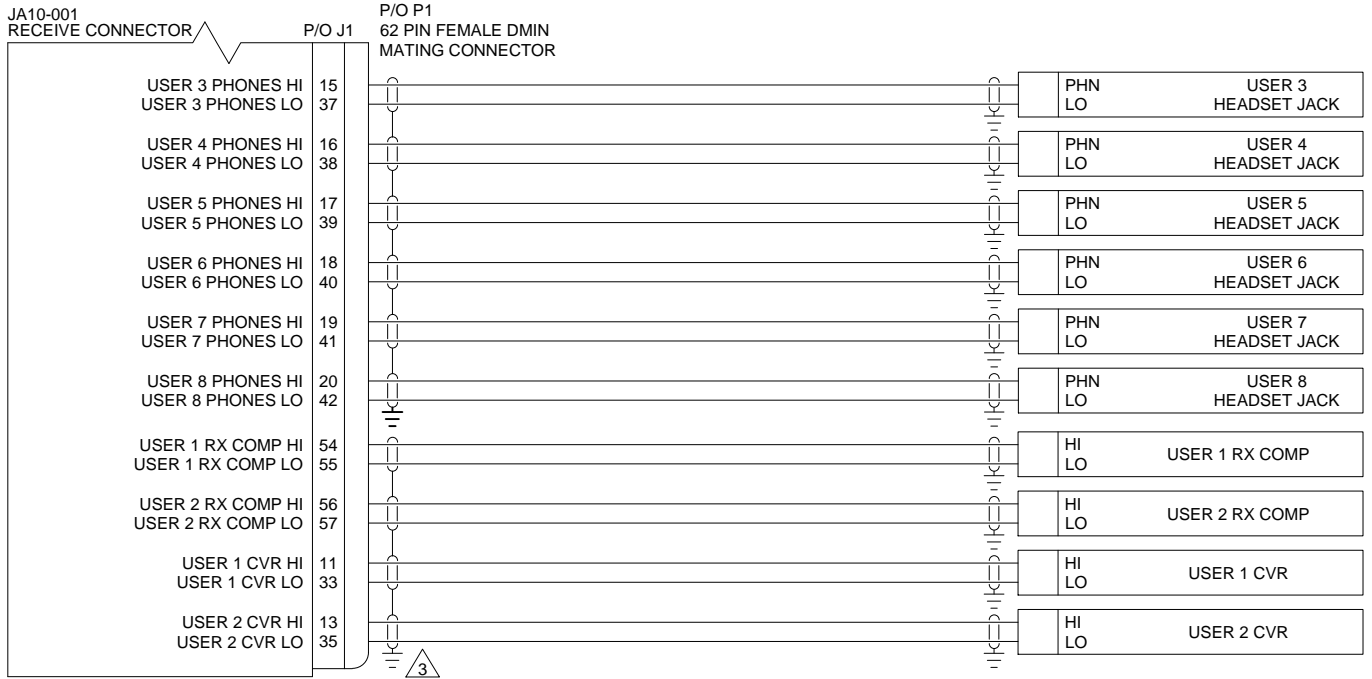



PREPARED	TAT			
CHECKED				
APPROVED		Audio Controller - Ten Transceiver P/O J1 Interconnect		SHEET
CONFIDENTIAL & PROPRIETARY TO JUPITER AVIONICS CORP.		NCAGE CODE L00N3	PART NO. JA10-001	2/7
		DOC NO. JA10-001 Interconnect Rev B.dwg		

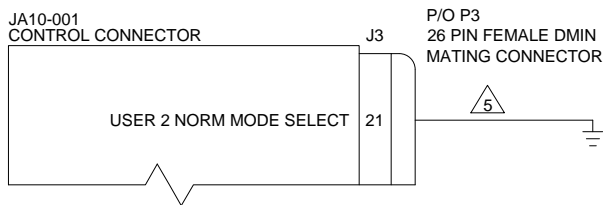
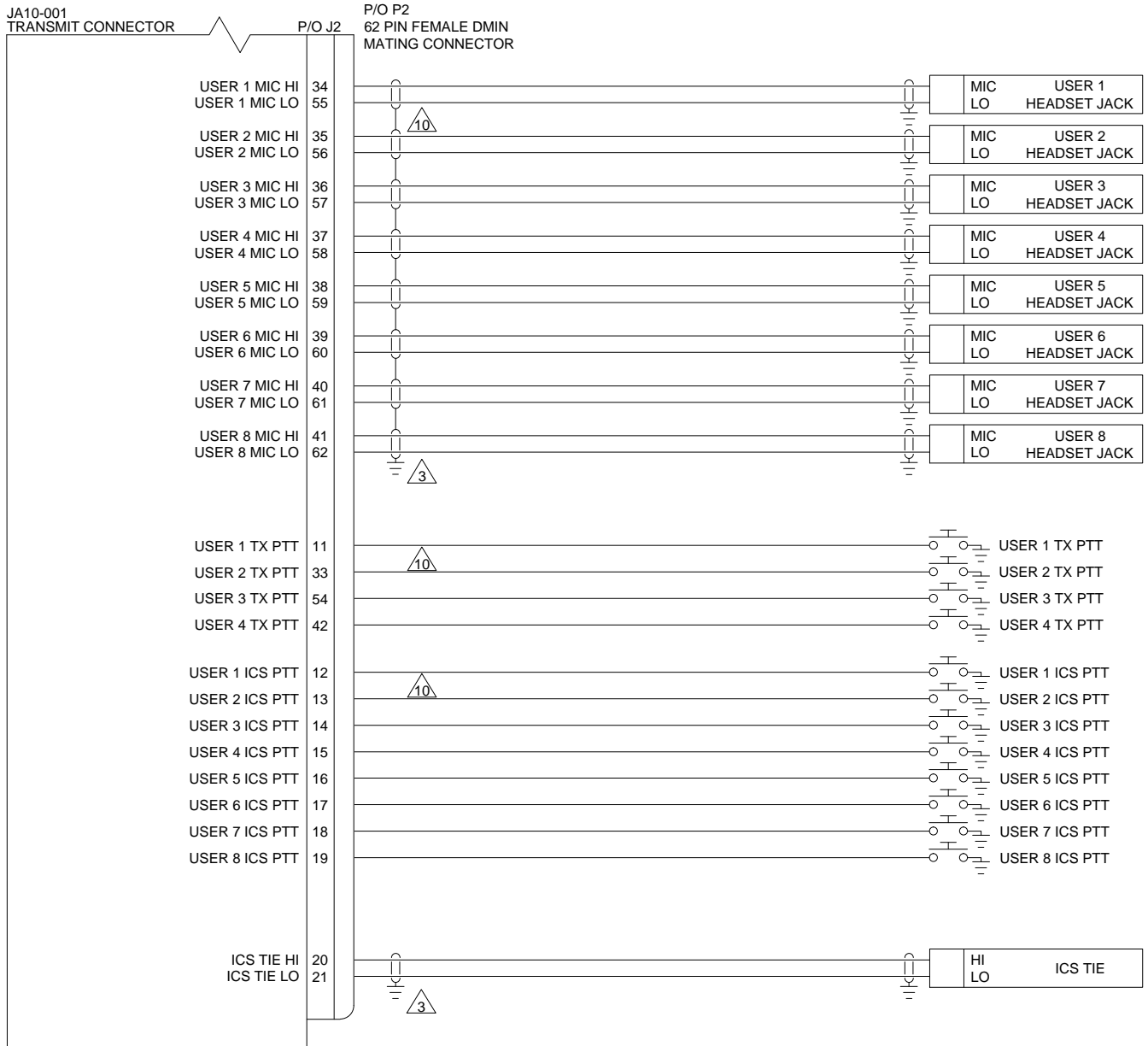

PREPARED	TAT	 <b>JUPITER AVIONICS</b> CORPORATION		
CHECKED				
APPROVED		NCAGE CODE	PART NO.	SHEET
CONFIDENTIAL & PROPRIETARY TO JUPITER AVIONICS CORP.		L00N3	JA10-001	3/7
		DOC NO. JA10-001 Interconnect Rev B.dwg		





PREPARED	TAT			
CHECKED				
APPROVED		Audio Controller - Ten Transceiver P/O J2 Interconnect		SHEET
CONFIDENTIAL & PROPRIETARY TO JUPITER AVIONICS CORP.		NCAGE CODE L00N3	PART NO. JA10-001	4/7
		DOC NO. JA10-001 Interconnect Rev B.dwg		

JA10-001  
CONTROL CONNECTOR

J3  
P3  
26 PIN FEMALE DMIN  
MATING CONNECTOR

OPTION: USER 2 CONTROL PANEL

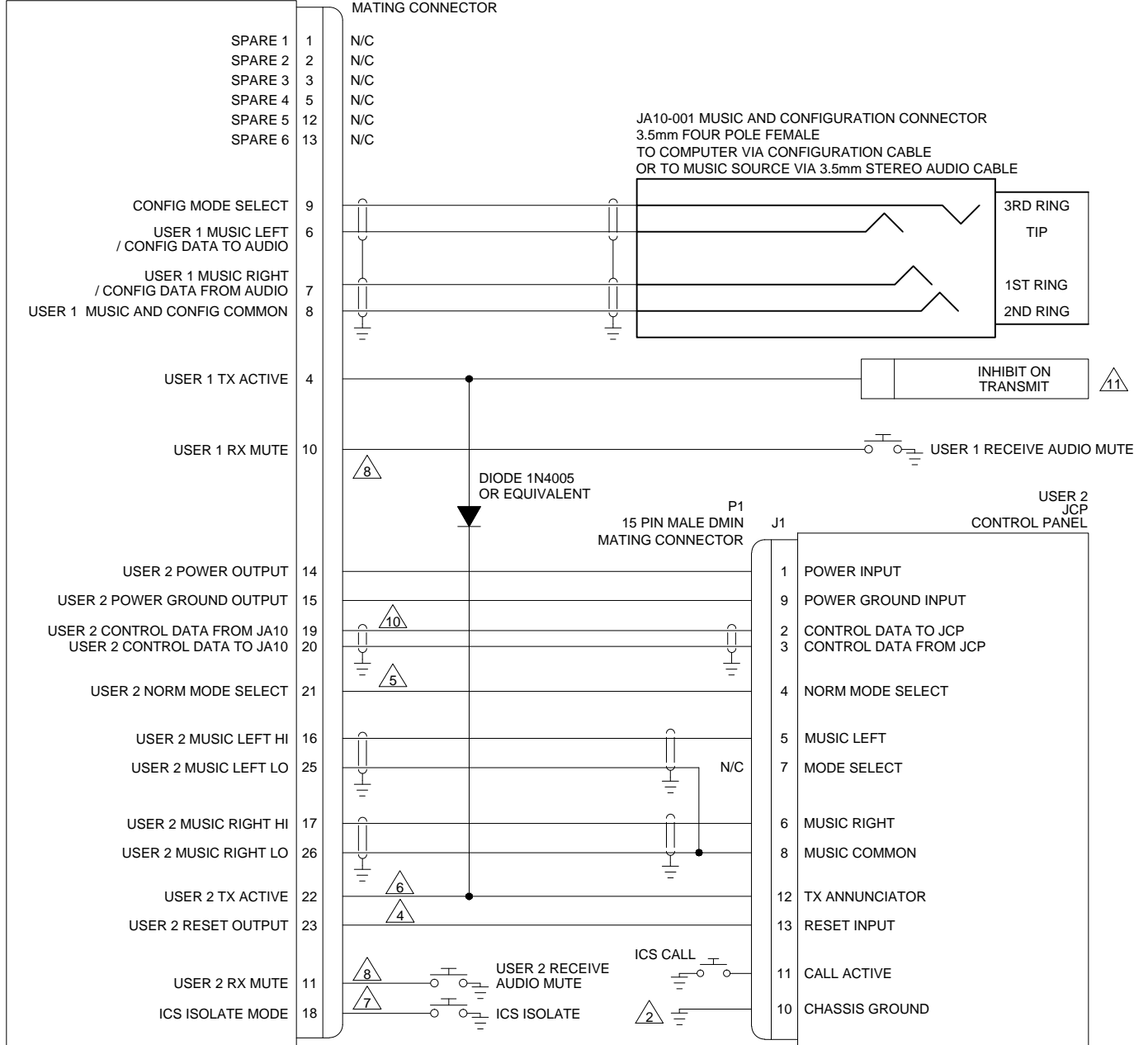

JA10-001  
MUSIC CONFIGURATION CONNECTOR

J5  
3RD RING  
TIP  
1ST RING  
2ND RING

FOUR POLE MALE 3.5MM STEREO  
MATING CONNECTOR

PART OF  
CONFIGURATION CABLE  
CAB-USB-0006  
or JA99-001

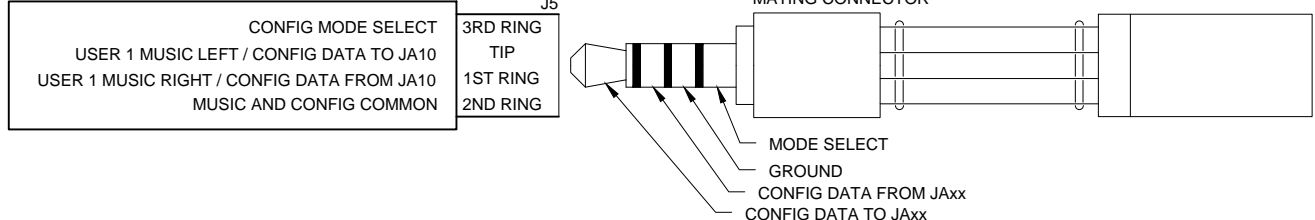

PREPARED	TAT			
CHECKED				
APPROVED		NCAGE CODE L00N3	PART NO. JA10-001	SHEET 5/7
CONFIDENTIAL & PROPRIETARY TO JUPITER AVIONICS CORP.		DOC NO. JA10-001 Interconnect Rev B.dwg		

OPTION: MULTIPLE AUDIO CONTROLLER

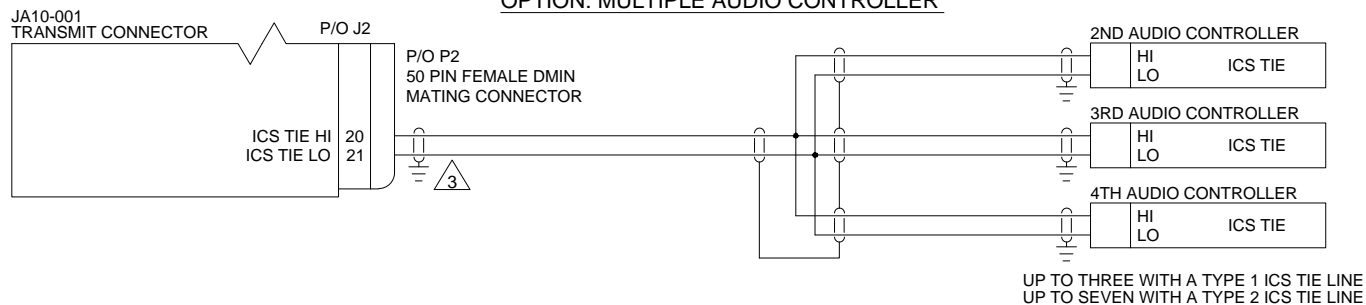

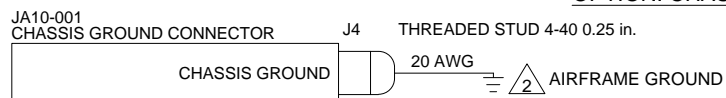

OPTION: CHASSIS GROUND



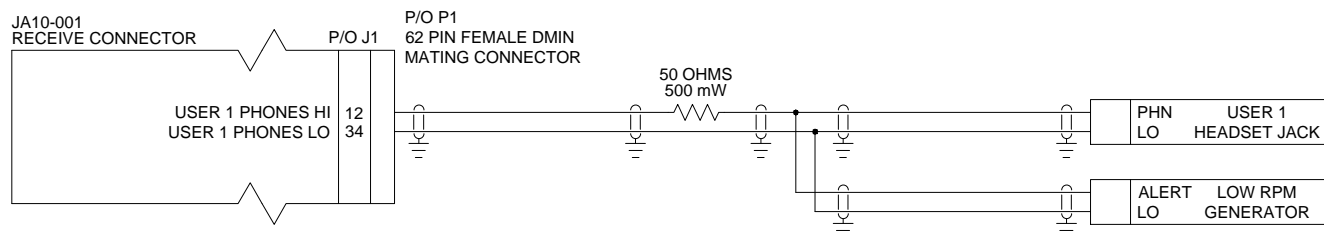

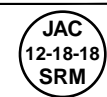

OPTION: LOW RPM TACH GENERATOR ALERT SYSTEM



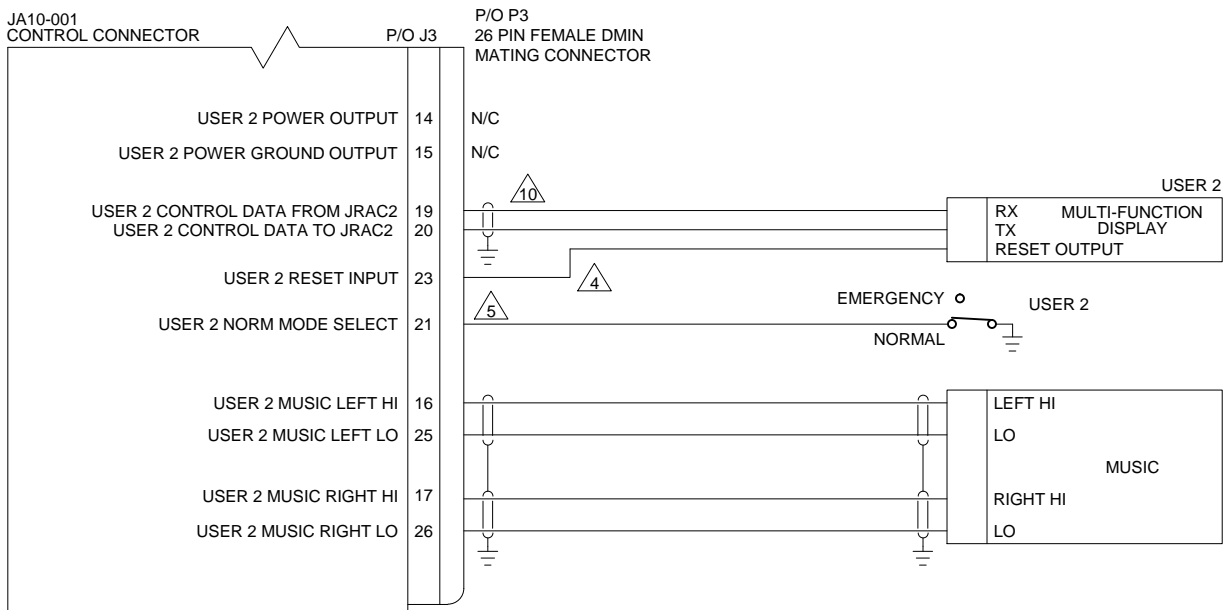

PREPARED	TAT			
CHECKED				
APPROVED		Audio Controller - Ten Transceiver J2 & J4 Interconnect Options		SHEET
		NCAGE CODE	PART NO.	6/7
		L00N3	JA10-001	
CONFIDENTIAL & PROPRIETARY TO JUPITER AVIONICS CORP.		DOC NO. JA10-001 Interconnect Rev B.dwg		

**OPTION: MULTI-FUNCTION DISPLAY CONTROL FOR USER 2**

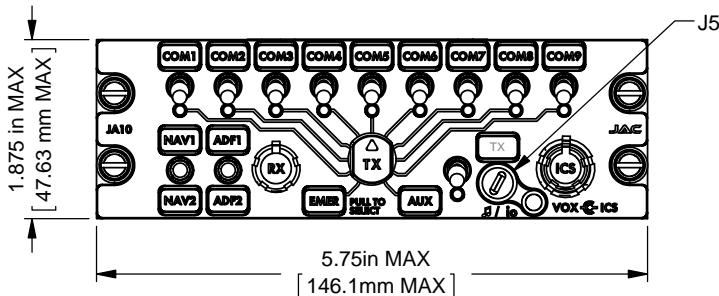
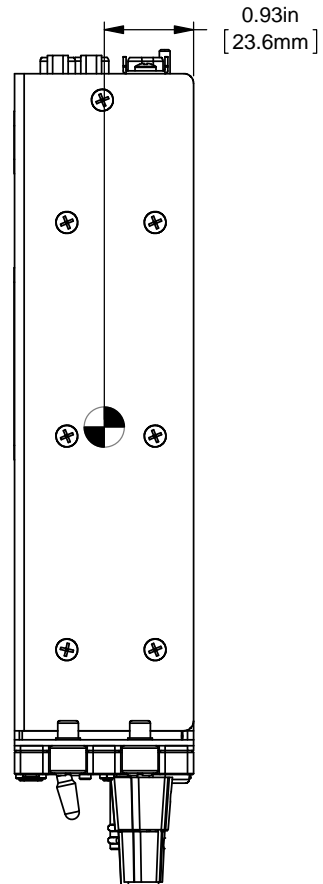
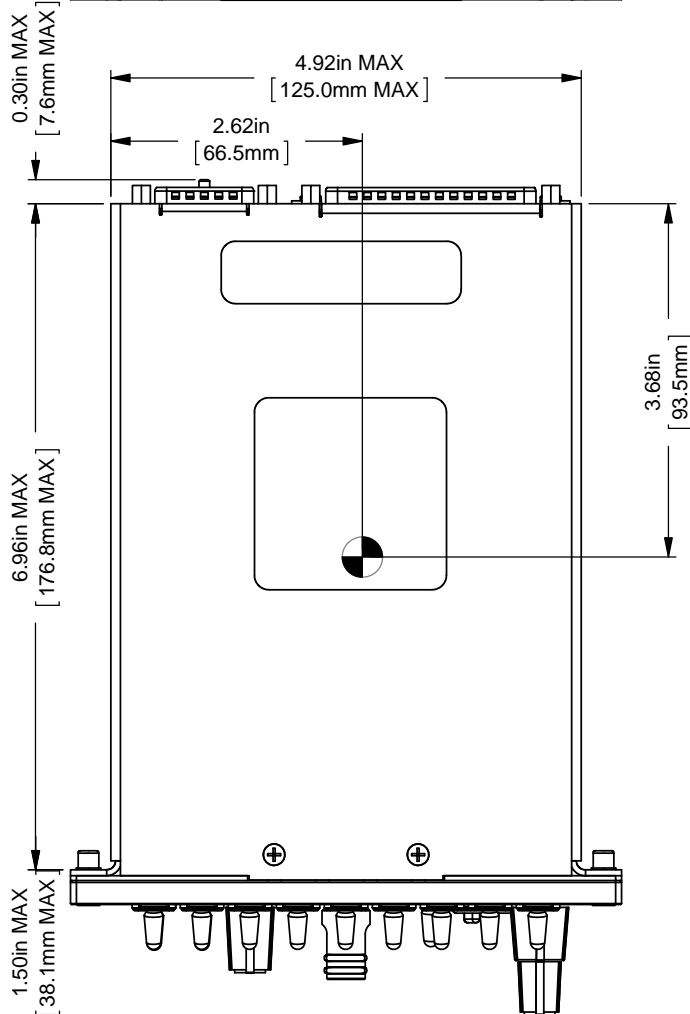
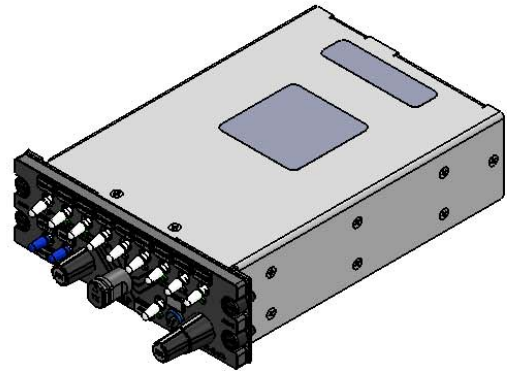
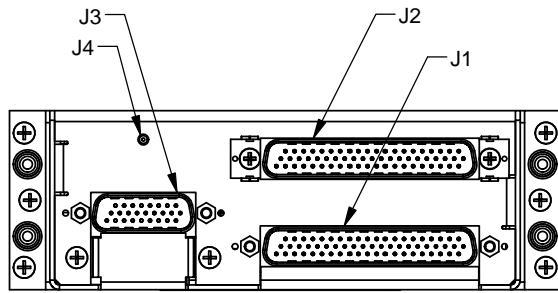

PREPARED	TAT			
CHECKED				
APPROVED		NCAGE CODE	PART NO.	SHEET
CONFIDENTIAL & PROPRIETARY TO JUPITER AVIONICS CORP.		L00N3	JA10-001	7/7
		DOC NO. JA10-001 Interconnect Rev B.dwg		



 CENTER OF GRAVITY  
±0.03in [0.8mm]

WEIGHT: 2.49 lbs [1.13 kg] MAX.

UNLESS OTHERWISE SPECIFIED  
DIMENSIONS ARE IN INCHES  
ANGLES ARE IN DEGREES  
TOLERANCES:  
1 DEC PLACE: ± 0.1  
2 DEC PLACE: ± 0.01  
3 DEC PLACE: ± 0.005  
ANGLES: ± 0.5 DEG

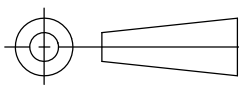

MATERIAL: N/A  
FINISH: N/A

PREPARED	TAT
CHECKED	JAC 12-17-18 SRM
APPROVED	JAC 12-17-18 KDV
CONFIDENTIAL & PROPRIETARY TO JUPITER AVIONICS CORP. DRAWING NOT TO SCALE	



**JUPITER AVIONICS**  
CORPORATION

TITLE

Audio Controller - Ten Transceiver

NCAGE CODE  
L00N3

PART NO.  
JA10-001

SHEET  
1/1

DOC. NO.  
JA10-001 Mechanical Installation Rev A.SLDDRW

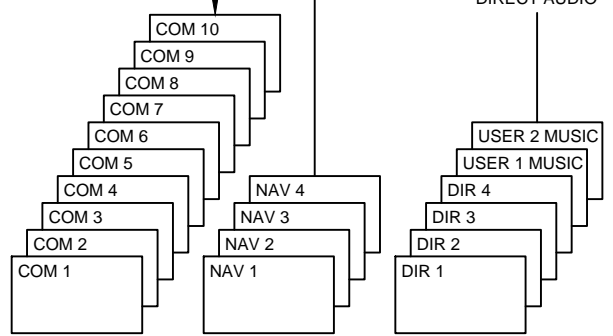
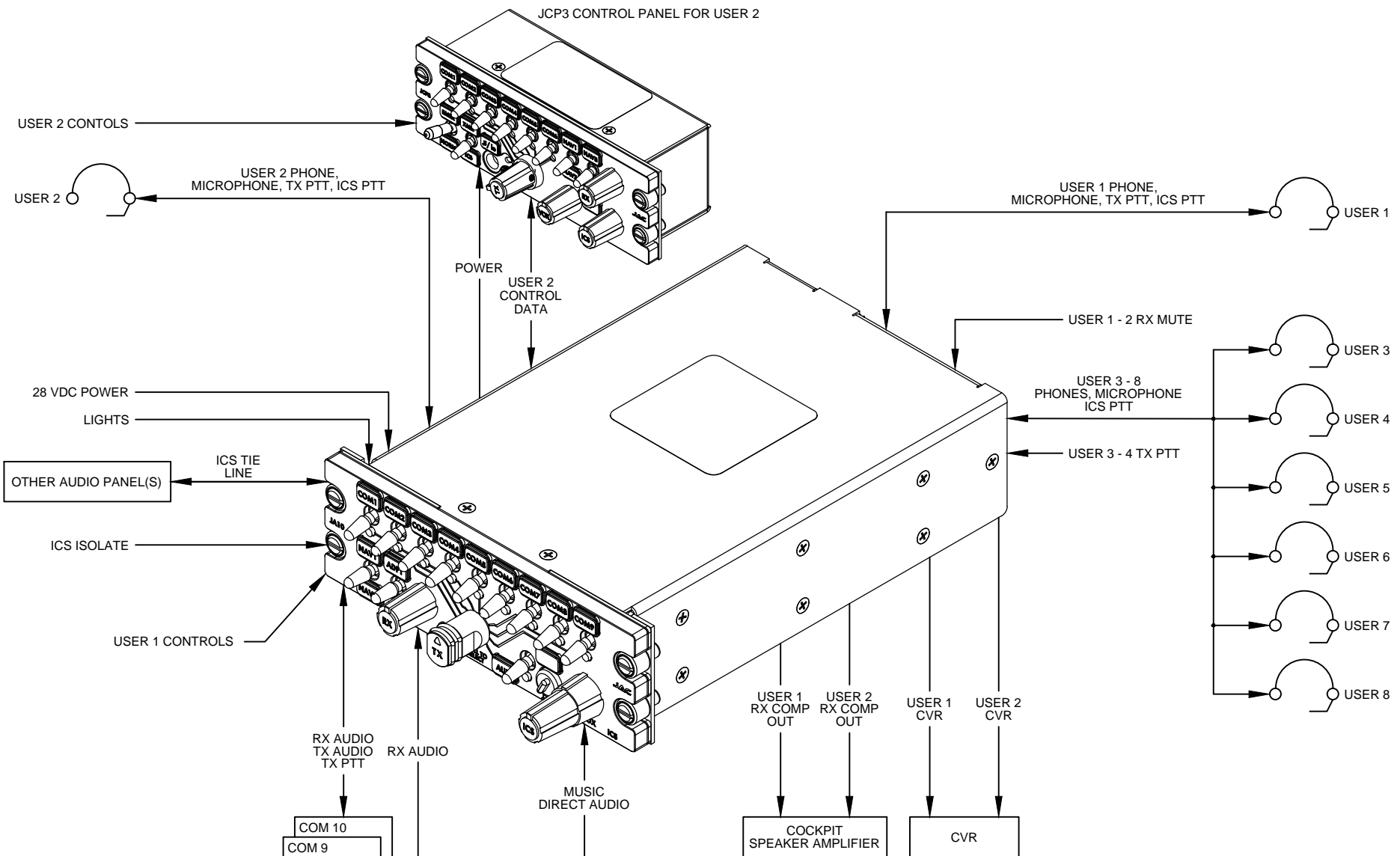

PREPARED	TAT	 <b>JUPITER AVIONICS CORPORATION</b>		
CHECKED	<b>JAC</b> 12-17-18 <b>SRM</b>			
APPROVED	<b>JAC</b> 12-17-18 <b>KDV</b>	<b>Audio Controller - Ten Transceiver Equipment Block Diagram</b>		
CONFIDENTIAL & PROPRIETARY TO JUPITER AVIONICS CORP.		NCAGE CODE L00N3	PART NO. JA10-001	SHEET 1
		DOC NO. JA10-001 Equipment Block Diagram Rev A.dwg		



## Field-Replaceable Legends

Jupiter Avionics Corporation (JAC) products have field-replaceable illuminated legends. This permits easy customization, and allows the same units to be used in multiple different configurations with only minimal changes.

The internal circuitry ensures that, although the legends are individually illuminated, the illumination is consistent and uniform throughout all legends, and never needs to be balanced. This means that if it is a requirement to change the labelling due to damage or for a different project, there is no need for costly and time-consuming illumination checks.

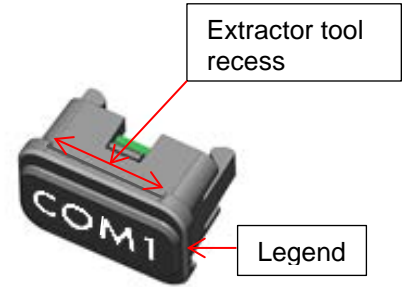

### Legend Removal



Caution: Take care not to scratch or otherwise damage the faceplate or the legend.

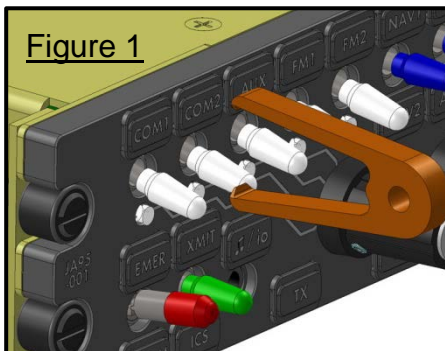

Figure 1

To facilitate legend removal, JAC provides a legend extractor tool - part # TOL-CUST-EXTR (figure 1) that fits into the recesses on the legend.

To remove a legend, hold the extractor firmly between the forefinger and thumb, and use a tweezer-like action to grip the legend (figure 2).

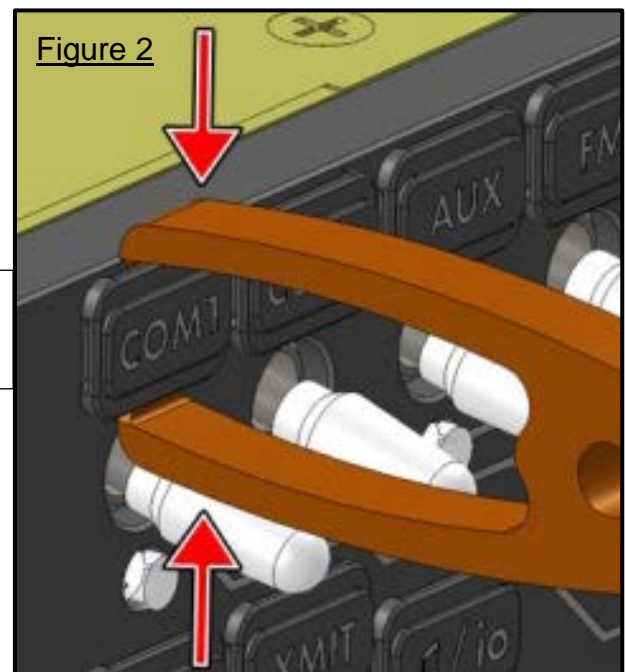

Figure 2

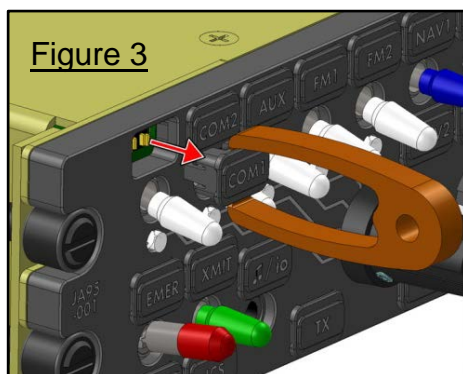

Figure 3

Pull the legend away from the faceplate as shown in figure 3.

### Legend Replacement

To replace a legend, align the text correctly, and then apply gentle pressure until the body of the legend support seats firmly into the faceplate.

Once the new legend is in place, ensure that it has seated correctly by checking that it illuminates. The unit is now ready for use.



# **Installation and Operating Manual**

## **Appendix B - Certification Documents**





## **B1**      **Airworthiness Approval**

Airworthiness approval of the JA10-001 may require completion of a TCCA Major Modification Report per CAR STD (AWM) 571 Appendix L, or a FAA Form 337. The sample wording for a description of the work is provided to assist the Installing Agency in preparing Instructions for Continued Airworthiness (ICA) when replacing an existing audio panel with a Jupiter Avionics JA10-001 Audio Controller - Ten Transceiver. This sample may be modified appropriately for new installations. It is the installer's responsibility to determine the applicability of the method used. Installations performed outside Canada must follow the applicable aviation authority's regulations.

### **Sample Wording:**

Removed the existing [model] audio panel and replaced with a Jupiter Avionics JA10-001 Audio Controller - Ten Transceiver in [aircraft location].

Installed in accordance with the JA10-001 Installation Manual, Revision [ ], and AC 43.13-2, Chapters 2, and 3.

The JA10-001 interfaces with existing aircraft systems per the Installation Manual instructions.

The JA10-001 Installation Manual provides detailed installation instructions and wiring diagrams (Section 2, and Appendices A and B).

Power is supplied to the JA10-001 through an existing [ ]-Amp circuit breaker that was previously used by the original audio panel. The net electrical load is unchanged.

Aircraft equipment list, weights and balance amended. Compass compensation checked and found to conform to applicable regulations.

## **B2**      **Instructions for Continued Airworthiness**

Maintenance of the JA10-001 Audio Controller - Ten Transceiver is "on condition" only. Refer to the JA10-001 Maintenance Manual. Periodic maintenance of the JA10-001 is not required.

The following sample Instructions for Continued Airworthiness (ICA) provides assistance in preparing ICA for the Jupiter Avionics JA10-001 unit installation as part of a Type Certificate (TC) or Supplemental Type Certificate (STC) project to comply with CAR STD (AWM) 523/527/525/529.1529 or FAR 23/25/27/29.1529 "Instructions for Continued Airworthiness".

Items that may vary by aircraft make and model are shown in brackets ("[ ]") and should be filled in as appropriate. Some of the checklist items do not apply, in which case they should be marked "N/A" (Not Applicable).

## **Instructions for Continued Airworthiness, Jupiter Avionics JA10-001 Audio Controller - Ten Transceiver in an [Aircraft Make and Model]**

### **1. Introduction**

[Aircraft that has been altered: Registration number, Make, Model and Serial Number]

**Content, Scope, Purpose and Arrangement:** This document identifies the Instructions for Continued Airworthiness for a Jupiter Avionics JA10-001 installed in an [aircraft make and model].

**Applicability:** Applies to a Jupiter Avionics JA10-001 installed in an [aircraft make and model].

**Definitions/Abbreviations:** None, N/A.

**Precautions:** None, N/A.

**Units of Measurement:** None, N/A.

**Referenced Publications:** JA10-001 Installation and Operating Manual  
JA10-001 Maintenance Manual  
JA10-001 Operating Manual  
STC/TC # [applicable STC/TC number for the specific aircraft installation]

**Distribution:** This document should be a permanent aircraft record.



## **2. Description of the System/Alteration**

Jupiter Avionics JA10-001 Audio Controller - Ten Transceiver with interface to external transceivers and [include other equipment/systems as appropriate]. Refer to Appendix A of this manual for interconnect information. Refer to aircraft manufacturer approved interconnect for actual installation.

## **3. Control, Operation Information**

Refer to section 3 of this manual or to the Jupiter Avionics JA10-001 Operating Manual.

## **4. Servicing Information**

N/A

## **5. Maintenance Instructions**

Maintenance of the JA10-001 is 'on condition' only. Periodic maintenance is not required. Refer to the JA10-001 Maintenance Manual.

## **6. Troubleshooting Information**

Refer to the JA10-001 Maintenance Manual.

## **7. Removal and Replacement Information**

Refer to Section 2 of this manual - the JA10-001 Installation and Operating Manual. If the unit is removed and reinstalled, a functional check of the equipment should be conducted.

## **8. Diagrams**

Refer to Appendix A of this manual - the JA10-001 Installation and Operating Manual - for installation drawings and interconnect examples.

## **9. Special Inspection Requirements**

N/A

## **10. Application of Protective Treatments**

N/A

## **11. Data: Relative to Structural Fasteners**

JA10-001 and appropriate mounting hardware installation, removal and replacement should be in accordance with applicable provisions of AC 43.13-1B and AC 43.13-2A.

## **12. Special Tools**

N/A

## **13. This Section is for Commuter Category Aircraft Only**

A. **Electrical loads:** Refer to Section 1 of the JA10-001 Installation and Operating Manual.

B. **Methods of balancing flight controls:** N/A.

C. **Identification of primary and secondary structures:** N/A.

D. **Special repair methods applicable to the airplane:** N/A.

## **14. Overhaul Period**

No additional overhaul time limitations.

## **15. Airworthiness Limitation Section**

N/A