



JUPITER AVIONICS
CORPORATION

JA97-002

Audio Controller with RX Volume Controls



Installation and Operating Manual

Rev A

Jupiter Avionics Corporation
1959 Kirschner Road
Kelowna BC
Canada V1Y 4N7
Tel: +1 778 478 2232
Toll-Free: 1 855 478 2232
www.jupiteravionics.com



Table of Contents

SECTION 1 - DESCRIPTION	1
1.1 System Overview	1
1.2 Features Overview	1
1.3 Inputs and Outputs	2
1.3.1 Inputs	2
1.3.2 Outputs	2
1.3.3 Bi-directional Ports	2
1.4 Specifications	3
1.4.1 Electrical Specifications	3
1.4.2 Mechanical Specifications	5
1.4.3 Environmental Specifications	5
1.4.4 Flammability of Materials	5
SECTION 2 – INSTALLATION	6
2.1 Introduction	6
2.2 Continued Airworthiness	6
2.3 Unpacking and Inspecting Equipment	6
2.3.1 Warranty	6
2.4 Installation Procedures	6
2.4.1 Installation Limitations	6
2.4.2 Cabling and Wiring	6
2.4.3 Mechanical Installation	7
2.4.4 In-Line PTT Cordsets	7
2.4.5 Legend Replacement	7
2.4.6 Post Installation Checks	7
2.5 Adjustments and Configuration using ProCS™	8
2.5.1 Configuration Cabling Requirements	8
2.5.2 ProCS™ Setup	8
2.5.3 Configurable Settings	8
2.5.4 Other Configuration Features	15
2.6 Installation Kit	15
2.6.1 Recommended Crimp Tools	15
2.7 Installation Drawings	15
2.7.1 Generation of Custom Drawings	15
SECTION 3 – OPERATION	16
3.1 Introduction	16
3.2 Front Panel Controls	16
(1) Transceiver Controls and Annunciators	17
(2) Receiver Controls and Annunciators	17
(3) Master Receive Volume Control	17
(4) Mode Switch	18
(5) Multi-function (Transmit/ICS) Switch	18
(6) Music/Configuration Connector (♫/io)	18
(7) Transmit Annunciator - TX	18
(8) Transmit Selector	19
(9) VOX Threshold Control	19
(10) CALL Annunciator	19
(11) ICS Volume Control	19
3.3 Normal Operation Mode	20
3.3.1 Panel Lighting	20
3.3.2 Receiving	20
3.3.3 Transmitting (Transmit Operation)	20
3.3.4 FM2 PTT Operation	20
3.3.5 VOX Operation	20
3.3.6 ICS Operation	20
3.3.7 Multi-Function (XMIT / ICS) Switch Operation	21
3.3.8 Music Operation	21



3.4	Emergency Operation Mode	21
3.4.1	Auto Emergency Mode.....	21
3.4.2	Selected Emergency Mode	21
Appendix A - Installation Drawings.....		A1
A1	Introduction.....	A1
A2	Installation Drawings	A1
Appendix B - Installation Documents		B1
B1	Airworthiness Approval	B2
B2	Instructions for Continued Airworthiness	B2

JA97-002 Audio Controller with RX Volume Controls

SECTION 1 - DESCRIPTION

1.1 System Overview

The JA97-002 audio controller is a centralized audio management system that distributes and controls all transceiver, receiver and alert audio in an aircraft. It enables the selected transmission of microphone audio to a transceiver and distributes all intercom audio.

The JA97-002 audio controller can be used in a standalone configuration or a star configuration to prevent the loss of the entire system due to the failure of one controller. It provides an emergency operating mode that connects the primary user (pilot) to COM1, NAV1 and Direct Audio 1, or to COM2, NAV2 and Direct Audio 2 sources (selectable via ProCS™).

The JA97-002 is set up on a per-installation basis using a configuration cable and a PC running the product configuration tool to download system configuration settings via the front panel music / configuration connector (M/i/o) without the necessity of removing the unit from the panel. To facilitate future customizations and certification, no software or complex electronic devices are used in the JA97-002 design.

1.2 Features Overview

The JA97-002 features a 37-pin D-Sub connector, which interfaces with the radio receive audio and crew phones, a 50-pin D-Sub connector which interfaces with the power and passenger headset connections. This layout minimizes crosstalk and follows industry standard interconnect for multi-user Audio Controllers.

Many of the input and output levels are adjustable, several audio paths are selectable, and alert audio analog waveforms can be loaded using the configuration program ProCS™ (**P**roduct **C**onfiguration **S**oftware) to write configuration commands via the JA99-001 configuration cable to the front panel music / configuration connector. The audio waveforms are stored in non-volatile devices. The alert audio feature is intended for use as a secondary alerting system where another device provides the primary annunciation.

The JA97-002 provides intercom functions for up to seven users. It supports up to 6 transceivers, each selectable from a rotary switch, and up to 5 receivers (2 on each of 2 toggle switches and 3 on the other).

The JA97-002 features individual VOX gating, and supports two Direct Audio inputs to provide audio at a fixed level to the users.

The JA97-002 has a CVR output and a two channel Alert Generator. Each alert has a separate key input.

The JA97-002 allows transmit access for three crew members (Pilot, Co-pilot, and Passenger 1).

A Music / Configuration connector is provided on the faceplate of the JA97-002 for configuration of audio levels and routing. The port can also be used as a music input and is compatible with most music players.

The JA97-002 has two modes of operation: Normal Mode and Emergency Mode.

The JA97-002 has Emergency Mode radio selection.



1.3 Inputs and Outputs

Refer to the JA97-002 [connector maps](#) for the mating connector designators and pin assignments for the input and output signals.

1.3.1 Inputs

Name	Qty	Type
ALERT ENABLE	1	Active high discrete
ALERT KEY	2	Active low discrete (Feature selected from ProCS)
CALL	1	Active low discrete (Feature selected from ProCS)
CONFIG DATA TO JA97	1	Data signal
DIRECT AUDIO	2	Audio signal
FRONT PANEL MUSIC	2	Audio signal
LIGHTS INPUT	1	Analog control signal
MIC	7	Audio signal
MODE SELECT / CONFIG AUDIO	1	Multi format signal
MUSIC	2	Audio signal
PAX 1 ICS PTT	1	Active low discrete (Feature selected from ProCS)
PAX 1 TX PTT	1	Active low discrete (Feature selected from ProCS)
PILOT and COPILOT ICS PTT	2	Active low discrete
PILOT and COPILOT TX PTT	2	Active low discrete
POWER INPUT	1	14 to 28 Vdc power supply
RX AUDIO	11	Audio signal

1.3.2 Outputs

Name	Qty	Type
CVR	1	Audio signal
CONFIG DATA FROM JA97	1	Data signal
PHONES	7	Audio signal Note: There are 6 outputs for driving 7 phones.
MF SW (Multifunction Switch)	2	Active low discrete (Feature selected from ProCS)
MIC	6	Audio signal
PTT	6	Active low discrete (PA PTT feature selected from ProCS)
RX COMP OUT	1	Audio signal (Feature selected from ProCS)

1.3.3 Bi-directional Ports

Name	Qty	Type
ICS TIE	1	Audio signal



1.4 Specifications

1.4.1 Electrical Specifications

Power Input

Primary nominal voltage	28 Vdc
Secondary nominal voltage	14 Vdc
Maximum voltage	32.2 Vdc
Minimum voltage	10.2 Vdc
Emergency voltage	9.0 Vdc
Input current at 28 Vdc	≤ 0.7 A
Input current at 14 Vdc	≤ 1.4 A

1.4.1.1 Audio Performance

Rated Input Level

Receive audio rated input level	7.75 Vrms ±10%
Direct audio rated input level	7.75 Vrms ±10%
Music rated input level	400 mVrms ±10%
Microphone input level	250 mVrms ±10%
Intercom Tie Line type 1 input level	340 mVrms ±10%
Intercom Tie Line type 2 input level	1.20 Vrms ±10%
CONFIG AUDIO input level	400 mVrms ±10%

Rated Output Level

Phone rated output	7.75 Vrms±10%
Pilot Phone rated output, in emergency mode or with power input ≤6 Vdc	2.20 Vrms±10%
Phone rated output power, with MUSIC input	3.88 Vrms±10%
Microphone rated output	250 mVrms±10%
CVR rated output	500 mVrms±10%
CVR rated output with input as MUSIC	250 mVrms±10%
CVR rated output with input as PILOT MIC	1.00 Vrms±10%
CVR rated output, in emergency mode,	500 mVrms ±10%
Receive Composite rated output	2.5 Vrms ±10%
Intercom Tie Line type 1 rated output	340 mVrms ±10%
Intercom Tie Line type 2 rated output	1.2 Vrms ±10%

Audio Frequency Response

Audio output audio frequency response	≤3dB from 300 to 6000 Hz
Alert audio output audio frequency response	≤3dB from 300 to 3000 Hz

Distortion Characteristics

Audio output distortion at rated power	≤10%
Audio output distortion at 10% of rated power	≤3%

Input Impedance

Microphone input Impedance	150 Ω ±10%
Direct Audio input Impedance	1000 Ω ±10%
Receive Audio input Impedance	1000 Ω ±10%
Music Audio input Impedance	1000 Ω ±10%
Intercom Tie Line Audio input Impedance	2000 Ω ±10%



Output Load

Phone load	600 Ω \pm 10%
Transceiver Microphone load	150 Ω \pm 10%
CVR load	5000 Ω \pm 10%
Receive Composite Audio load	600 Ω \pm 10%
Intercom Tie Line type 1 rated load	2000 Ω \pm 10%
Intercom Tie Line type 2 rated load	2000 Ω \pm 10%
Intercom Tie Line type 1 maximum load	666 Ω max (3 loads)
Intercom Tie Line type 2 maximum load	285 Ω max (7 loads)

Volume Controls

Receive Audio control variation	32 \pm 3dB
ICS Audio control variation	42 \pm 3dB

Input to output Crosstalk and Bleed-through Level

Input to Output crosstalk	\leq 55 dB
---------------------------	--------------

Input to Input Crosstalk Level

Input to Input crosstalk	\leq 60 dB
--------------------------	--------------

Audio Noise Level without Signal

Noise level below the rated output	\geq 60 dB
------------------------------------	--------------

Listening Test

Loud and Clear

1.4.1.2 Audio Performance, Other

CVR HI / LO output circuitry type (Normal)	differential
CVR HI / LO output circuitry type (Emergency)	single ended
Microphone inputs designed for MIC type	amplified dynamic
Microphone inputs bias voltage	11 Vdc \pm 10%
Microphone inputs circuitry type	single ended
MUSIC LEFT / RIGHT HI / LO audio input circuitry type	differential
FRONT MUSIC LEFT / RIGHT audio input circuitry type:	single ended
MUSIC attenuation	40 dB max
RECEIVE AUDIO input circuitry type	differential
PHN HI / LO output circuitry type	single ended
MIC output circuitry type	differential
RX Composite Audio output circuitry type	differential
ICS TIE HI / LO Circuitry Type	differential
PHN HI / LO output music fade in duration	2.5 \pm 1.0 seconds
VOX Threshold level range relative to rated MIC input	-30 to +12 dB
VOX Delay Time range	0.5 to 2.0 seconds
Transmit Timer duration	90 \pm 30 seconds

1.4.1.3 Discrete Signals

Active low control input, active signal level	\leq +3 Vdc
Active low control input, inactive signal level	\geq +10 Vdc
Active low control input, current	\leq 10 mAdc
Active low control output, active output	\leq +2 Vdc
Active low control output, active, current	\leq 1 Adc
ALERT ENABLE signal active signal level	\geq +9 Vdc
ALERT ENABLE signal, when active, sinks	\leq 10 mAdc
ALERT ENABLE signal inactive signal level	\leq +3 Vdc



1.4.1.4 Lights Input

LIGHTS INPUT ranges	0 to 28, 0 to 14 and 0 to 5 Vdc
LIGHTS INPUT current	10 mA max.

1.4.2 Mechanical Specifications

Height	2.625 in [66.7 mm] max
Behind panel depth	5.48 in [139 mm] max
Faceplate width	5.75 in [146 mm] max
Behind panel width	4.92 in [125 mm] max
Weight	2.23 lbs. [1.01 kg] max
Material	brushed aluminum with conversion coating
Connectors (4):	J1 One 37-pin D-Sub male J2 One 50-pin D-Sub male J3 One 4 pole 3.5mm stereo jacks J4 One ground stud, 4-40
Mounting	4 Dzus fasteners
Bonding	$\leq 2.5 \text{ m}\Omega$
Installation kit part number	INST-JA97
Faceplate	white legends on black
Faceplate legend colour, luminance	white, $1 \pm 0.5 \text{ fL}$

1.4.3 Environmental Specifications

Temperature:	
Operating	-45 °C to +70 °C
Ground Survival	-55 °C to +85 °C
Altitude	50,000 ft
Humidity	Cat A (48 hours)
Shock, Crash Safety	6 g, 20 g for 11 ms

1.4.4 Flammability of Materials

The JA97-002 complies with the requirements of RTCA/DO-160G Sec 26.3.3 "Flammability", through equivalent flammability testing of materials and the Small Parts Exemption.



JA97-002 Audio Controller with RX Volume Controls

SECTION 2 – INSTALLATION

2.1 Introduction

This section contains unpacking and inspection procedures, installation information, and post-installation checks.

2.2 Continued Airworthiness

Maintenance of the JA97-002 is on condition only. Scheduled inspection and/or periodic maintenance of this unit is not required.

2.3 Unpacking and Inspecting Equipment

Unpack the equipment carefully. Check for shipping damage and report any problems to the relevant carrier. Confirm that the Authorized Release Certificate or Certificate of Conformance is included. Complete the on-line warranty card from the Jupiter Avionics Corporation (JAC) website – www.jupiteravionics.com/warranty

2.3.1 Warranty

This product manufactured by JAC is warranted to be free of defects in workmanship or performance for 2 years from the date of installation by an approved JAC dealer or agency. This warranty covers the cost of all materials and labour to repair or replace the unit, but does not include the cost of transporting the defective unit to and from JAC or its designated warranty repair centre, or of removing and replacing the defective unit in the aircraft. This warranty does not cover failures due to abuse, misuse, accident, or unauthorized alteration or repairs.

THIS WARRANTY IS VOID IF THE PRODUCT IS NOT INSTALLED BY AN AUTHORIZED JAC DEALER. If the on-line warranty card is not completed, the product will be warranted from the date of manufacture.

Contact JAC for return authorization, and for any questions regarding this warranty and how it applies to your unit(s). JAC is the final arbiter concerning warranty issues.

2.4 Installation Procedures



WARNING: Loud noise can cause hearing damage. Set the headset volume to minimum before conducting tests, and slowly increase the volume to a comfortable listening level.



CAUTION: The power input circuitry of the unit may be damaged if the installation does not conform to the wiring instructions in this manual.

2.4.1 Installation Limitations

Those installing the JA97-002, on or in a specific type or class of aircraft, must determine that the aircraft installation conditions are within standards. The JA97-002 may be installed only by following the applicable airworthiness requirements.

2.4.2 Cabling and Wiring

All wire shall be selected in accordance with the original aircraft manufacturer's maintenance instructions, or AC43.13-1B Change 1, Paragraphs 11-76 through 11-78. Unshielded wire types shall qualify to MIL-W-22759 as specified in AC43.13-1B Change 1, Paragraphs 11-85, 11-86, and listed in Table 11-11. For shielded wire applications, use Tefzel



MIL-C-27500 shielded wire with tag ring or equivalent (for shield terminations) to make the most compact and easily terminated interconnect. Follow the Connector Map in Appendix A of this manual.

Allow 3" from the end of the shielded wiring to the shield termination to allow the connector hood to be easily installed. Refer to the Interconnect drawing in Appendix A of this manual for shield termination details. Note that this unit has a 'clamshell' hood that is installed after the wiring is complete.

Maintain wire segregation and route wiring in accordance with the original aircraft manufacturer's maintenance instructions.

Unless otherwise noted, all wiring shall be a minimum of 24 AWG, except power and ground lines, which shall be a minimum of 22 AWG. Refer to the Interconnect drawing for additional specifications. Check that the ground connection is clean and well secured, and that it shares no path with any electrically noisy aircraft accessories such as blowers, turn-and-bank instruments, or similar loads.

2.4.3 Mechanical Installation

The JA97-002 can be mounted in any attitude and location with adequate space for the front panel and sufficient clearance for the connector and wiring harness. It requires no direct cooling.

2.4.4 In-Line PTT Cordsets

If in-line PTT cordsets (drop cords) are used, be aware that incorrectly configured or improperly shielded in-line PTT cordsets can lead to significant audio problems.

2.4.5 Legend Replacement

The JA97-002 illuminated legends are field replaceable. For further information, refer to the '[Legend Replacement](#)' document in Appendix A of this manual.

2.4.6 Post Installation Checks

2.4.6.1 Voltage/Resistance checks.

Do not attach this unit until the following conditions are met:

- a) Check P1 pin **19** for lights buss voltage.
- b) Check P2 pin **16** for alert power.
- c) Check P2 pin **17** for +28 Vdc or +14 Vdc relative to ground.
- d) Check P2 pin **34** for continuity to ground (less than 0.5 Ω).
- e) Check P2 pins **6 thru 12** for continuity to ground (less than 0.5 Ω) when the relevant switch is closed.
- f) Check all pins for shorts to ground or adjacent pins.

2.4.6.2 Configuration

Ensure that the JA97-002 contains the correct configuration settings. This may be done at the factory, on the maintenance bench or in the aircraft before the power on checks are performed. Refer to section 2.5.1.

2.4.6.3 Power on Checks.

Power up the aircraft's systems and confirm normal operation of all functions of the JA97-002. Refer to Section 3 (Operation) for specific operational details.

- a) Begin with only the pilot's headset attached. Confirm correct ICS and radio operation for both receive and transmit. Check yoke or cyclic switch action. Check the radio selection and inputs. Do not proceed until the radios are functioning correctly.
- b) If there is a music source in the system, turn it on and check for proper mute operation.
- c) Unusual buzzes, hums or other background audio are symptomatic of multiple grounds, or noisy external systems such as blowers or pumps sharing wiring with the audio system. If a transmitter fails to key or



correctly modulate it is often the result of not connecting all required grounds to the radio or external audio system.

- d) Check the ICS operation and Emergency operation.
- e) Plug in the co-pilot's headset. Check for correct ICS operation. Check yoke or cyclic switch functions.
- f) Plug in any remaining headsets, and check for correct ICS operation. Note that an incorrect cordset (drop cord) or improper jack wiring may cause a wide range of problems, from loss of audio to a tone heard in the headset.
- g) Check that all configurations settings are correct.

When all performance checks are satisfied, complete the necessary regulatory documentation before releasing the aircraft for service. Refer to [Appendix B](#).

2.5 Adjustments and Configuration using ProCS™

All the JA94-001 internal adjustments are set from the [Product Configuration Software ProCS™](#). Configuration data is sent to the JA94-001 via the front panel connector (J10), using the Configuration Cables and a computer running the ProCS™ software. For configuration requirements, see section 2.5.1.

For full information on the configuration process, and for installation of ProCS™ on your computer, refer to the ProCS™ manual on the Jupiter Avionics website - www.jupiteravionics.com/productsoftware.

2.5.1 Configuration Cabling Requirements

To configure the JA94-001, it is necessary to load the [Product Configuration Software ProCS™](#) onto a Windows-based computer as described in the [ProCS™ manual](#).

The cables required to configure the JA97-002 are not included with the unit.

Cabling option 1: (Needed for Loading Alert Messages)

Quantity	Description	JA97-002
1	USB A to RS232 9-Pin Cable	CAB-USB-0002
1	Configuration Cable	JA99-001

Cabling option 2: (For Use Without Loading Alert Messages)

Quantity	Description	JA97-002
1	USB A Male to RS232 3.5mm Plug	CAB-USB-0006

2.5.2 ProCS™ Setup



The ProCS™ JA97-002 menu item 'ProCS Setup' provides Setup drawings showing the cabling arrangement for connecting the JA97-002 to a computer running the ProCS™.

2.5.3 Configurable Settings

A standard unit is shipped from the factory with all internal adjustments configured to the default levels. At installation, it may be desirable to change some of these settings to suit the local operating environment.



Note: To properly configure the JA97-002, power must be applied to the unit.

Within ProCS™, the configurable settings are grouped together into the following sections:



2.5.3.1 Front Panel Switches

The Front Panel Switches window is used to specify the text for each legend.

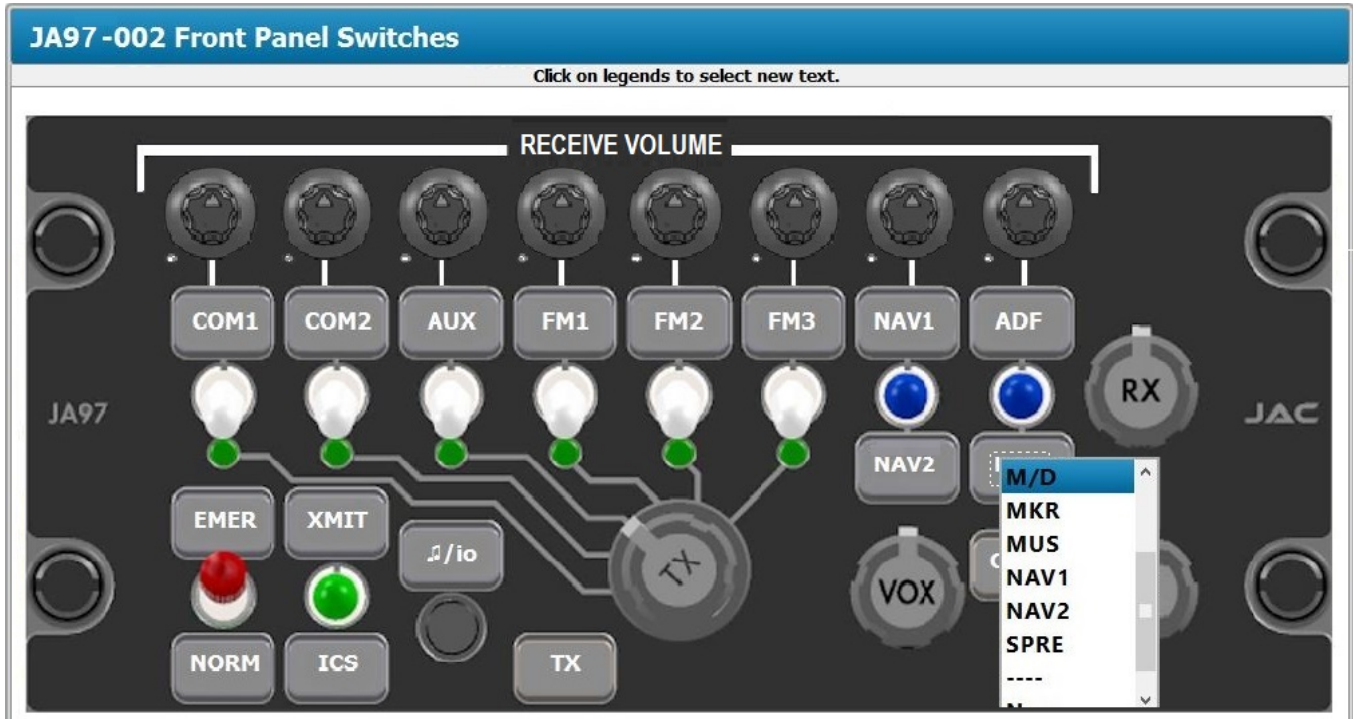

Note: If the name of a front panel switch is changed using this software, the change will be incorporated in every other section that refers to that switch name, including the connector maps, to give truly customized installation diagrams.

2.5.3.2 Radios

The Radios window is used to define the radios for the transceivers and receivers.





2.5.3.3 Receive Levels

JA97-002 Receive Levels

Input Levels

COM1	Default Transceiver :	1.00 Vrms		10.00 Vrms [7.75 Vrms]	Default Level
COM2	Default Transceiver :	1.00 Vrms		10.00 Vrms [7.75 Vrms]	Default Level
AUX	Default Transceiver :	1.00 Vrms		10.00 Vrms [7.75 Vrms]	Default Level
FM1	Default Transceiver :	1.00 Vrms		10.00 Vrms [7.75 Vrms]	Default Level
FM2	Default Transceiver :	1.00 Vrms		10.00 Vrms [7.75 Vrms]	Default Level
FM3	Default Transceiver :	1.00 Vrms		10.00 Vrms [7.75 Vrms]	Default Level
NAV1	Default Receiver :	1.00 Vrms		10.00 Vrms [7.75 Vrms]	Default Level
ADF	Default Receiver :	1.00 Vrms		10.00 Vrms [7.75 Vrms]	Default Level
M/D (MKR)	Default Receiver :	1.00 Vrms		10.00 Vrms [7.75 Vrms]	Default Level
NAV2	Default Receiver :	1.00 Vrms		10.00 Vrms [7.75 Vrms]	Default Level
M/D (DME)	Default Receiver :	1.00 Vrms		10.00 Vrms [7.75 Vrms]	Default Level
DIRECT1	Default Receiver :	1.00 Vrms		10.00 Vrms [7.75 Vrms]	Default Level
DIRECT2	Default Receiver :	Note: DIRECT 2 Rated Input Level is fixed (Not Adjustable)			

Other selections that can be made in the Receive Levels window are shown below:

Receive Audio Detector

0dB = Rated Input Level

Level: -12 dB -36 dB [-24 dB]

The Receive Audio Detector threshold can be adjusted from -36 to -12 dB of rated input level. **(Default -24 dB)**

Output Level

Rated Load Impedance = 600 Ohms

Receive Composite: 0.25 Vrms 2.50 Vrms [1.00 Vrms]

The level of the receive composite audio output (RX COMP OUT) can be adjusted from 0.25 to 2.5 Vrms. **(Default 1.0 Vrms)**

Note: The Receive Composite pin is configured on the [Connector Pin Configuration](#) page.



2.5.3.4 **Transmit Levels**

JA97-002 Transmit Levels

Transmit Levels

The level of each of the six Transceiver MIC output signals can be adjusted from 0.01 to 1 Vrms. **(Default 250 mVrms)**

Rated Load Impedance = 150 Ohms

COM1	Default Transceiver :	0.010 Vrms		1.000 Vrms	[0.250 Vrms]	Default Level
COM2	Default Transceiver :	0.010 Vrms		1.000 Vrms	[0.250 Vrms]	Default Level
AUX	Default Transceiver :	0.010 Vrms		1.000 Vrms	[0.250 Vrms]	Default Level
FM1	Default Transceiver :	0.010 Vrms		1.000 Vrms	[0.250 Vrms]	Default Level
FM2	Default Transceiver :	0.010 Vrms		1.000 Vrms	[0.250 Vrms]	Default Level
FM3	Default Transceiver :	0.010 Vrms		1.000 Vrms	[0.250 Vrms]	Default Level

When the Transmit Timeout check box is checked the transmit time-out is enabled **(Default not checked)**

When the FM2 Duplex check box is checked the COM5 (FM2) radio is set to duplex operation **(Default not checked)** (see [section 3.3.4](#))

Transmit Settings

Transmit Time-out (90 Sec.)

FM2 Duplex

2.5.3.5 **Sidetone Levels**

JA97-002 Sidetone Levels

Receive Sidetone Level

The Receive Sidetone Level can be adjusted from 0 to -12 dB of the rated phone Level. **(Default -6 dB)**

COM1 thru FM3 RX input Level on PHN output: 0 dB -12 dB **[-6 dB]**

2.5.3.6 **Connector Pin Configuration**

JA97 -002 Connector Pin Configuration

Multi Function Switch

Switch Operation: PILOT TX and ICS PTT MF SW OUTPUT PINS

J1 Contacts Selection

Pin 1/20:	<input checked="" type="radio"/> CVR HI/LO OUTPUT	<input type="radio"/> DIRECT AUDIO 2 HI/LO INPUT
Pin 14/33:	<input checked="" type="radio"/> MUSIC LEFT HI/LO INPUT	<input type="radio"/> RX COMP HI/LO OUTPUT
Pin 15/34:	<input checked="" type="radio"/> MUSIC RIGHT HI/LO INPUT	<input type="radio"/> DIGITAL TIE +/- INPUT
Pin 16/35:	<input checked="" type="radio"/> ICS TIE HI/LO INPUT/OUTPUT	<input type="radio"/> DIGITAL TIE +/- OUTPUT

J2 Contacts Selection

Pin 6:	<input checked="" type="radio"/> PAX 1 TX PTT INPUT	<input type="radio"/> MF SW 2 OUTPUT (ICS)	
Pin 11:	<input checked="" type="radio"/> PAX 1 ICS PTT INPUT	<input type="radio"/> ALERT 1 KEY INPUT	<input type="radio"/> MF SW 1 OUTPUT (XMIT)
Pin 12:	<input checked="" type="radio"/> ALERT 2 KEY INPUT	<input type="radio"/> CALL INPUT	<input type="radio"/> PAX 2 TX PTT INPUT

Several of the connector pins can be configured to meet the requirements of specific installations. Refer to JA97-002 [Interconnect sheet 5 of 6](#).

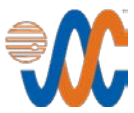

2.5.3.7 Alerts



WARNING: The internal audio alerts are intended only to supplement, not replace, airframe alerts such as 'low rotor RPM', 'engine out' or 'decision height alerting'. The alert audio feature is intended for use as a secondary alerting system where another device provides the primary annunciation.

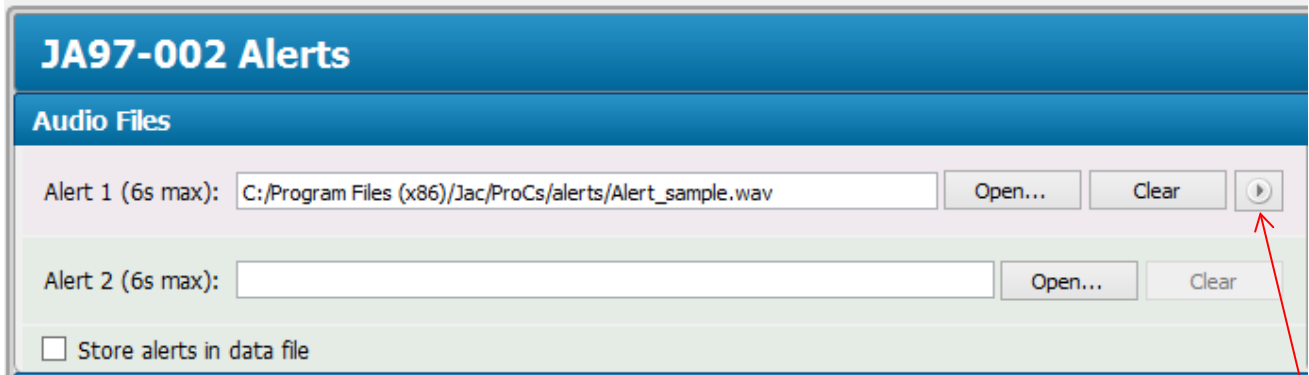

Saving new Audio Files

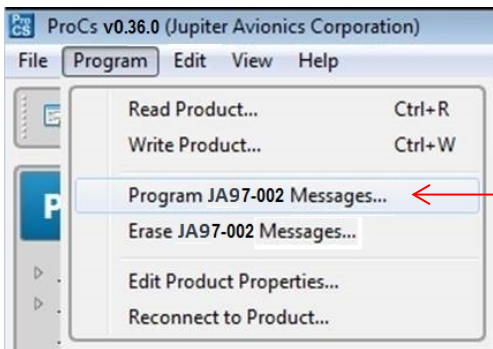

If a new audio file is selected, it may be played using the arrow to the right of the Message line.

It may be uploaded to the JA97-002 using the 'Program' menu and selecting 'Program JA97-002 Messages...'

Note that this pane will have different content if a JA95-N42 is not connected.

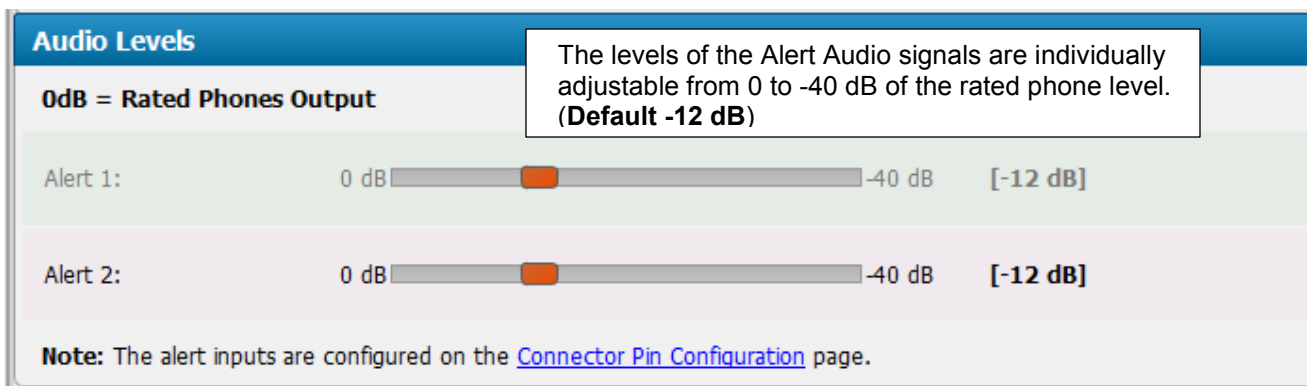

Audio Files

The JA97-002 has standard audio signals for each of the alerts, and the audio files window allows these signals to be customized with other recordings during the configuration process.

The default Alert signals loaded into the unit at the factory are:

JA97-002 Wav File (Sine 300Hz 10 sec) Rev A.WAV

JA97-002 Wav File (Sine 1000Hz 10 sec) Rev A.WAV



2.5.3.8 Audio Muting (During Transmit)

When the Mute RX Audio check box is checked the Receive Audio is muted during transmit (**Default checked**)

When the Mute ICS Audio check box is checked the ICS Audio is muted during transmit (**Default checked**)

When the Mute Alert Audio check box is checked the Alert Audio is muted during transmit (**Default not checked**)



2.5.3.9 CVR Level

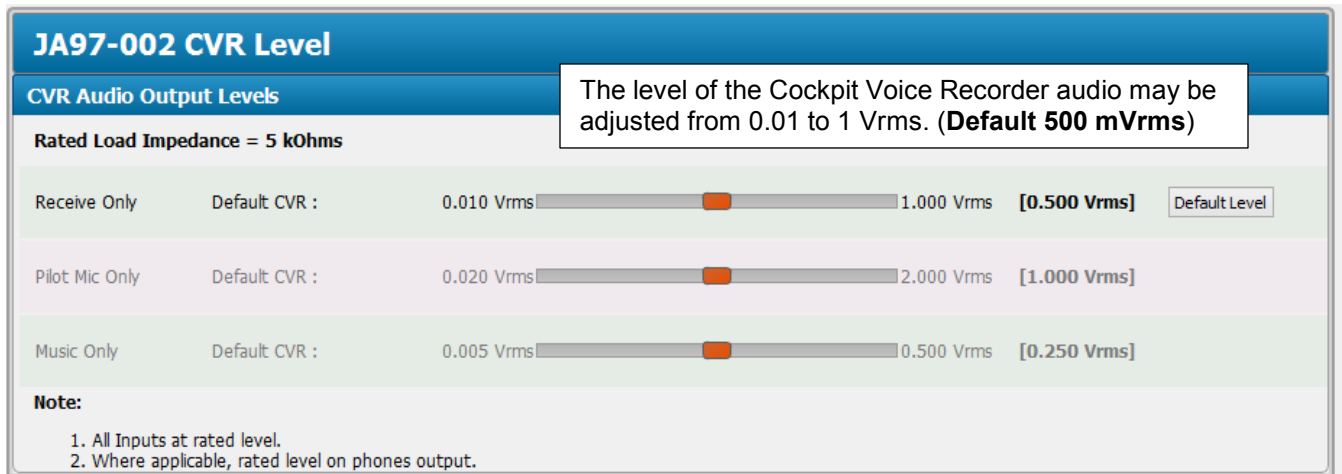

2.5.3.10 Music Levels

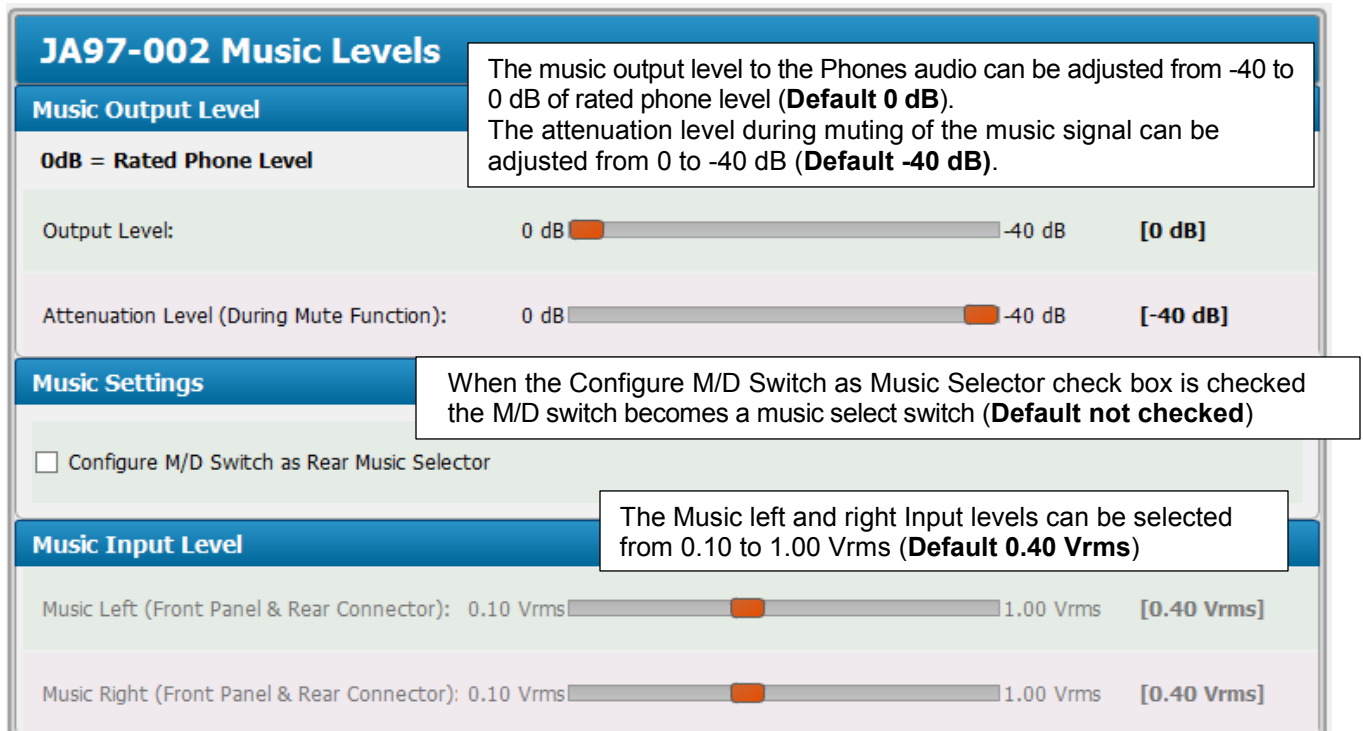



2.5.3.11 **ICS Tie Line**

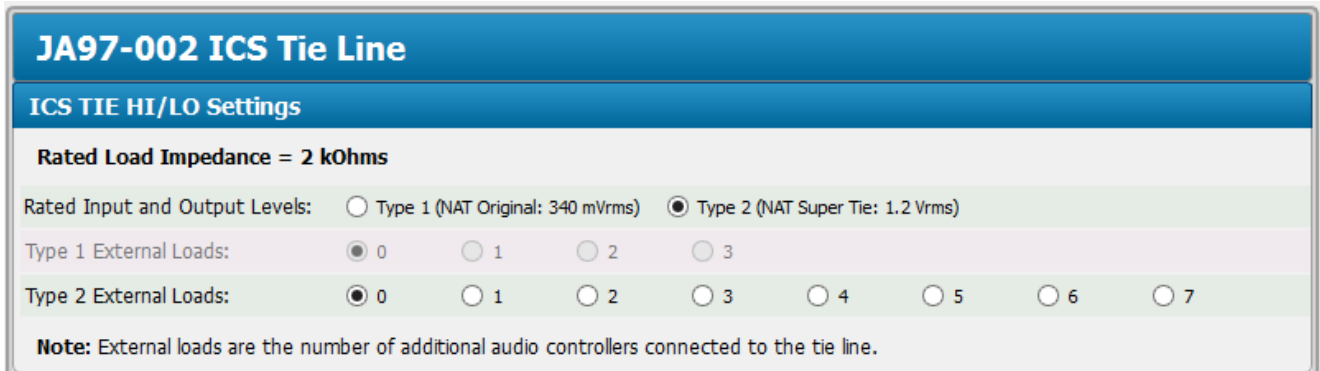

The rated input and output levels of the intercom tie line can be selected as Type 1 or Type 2 (**Default Type 2**). The quantity of external loads for a type1 intercom tie line can be selected from 0 to 3 (**Default 0**). The quantity of external loads for a type 2 intercom tie line can be selected from 0 to 7 (**Default 0**).

2.5.3.12 **Lighting Voltage Selection**



The rated input level of the LIGHTS INPUT signal may be +5 Vdc, +14 Vdc or +28Vdc (**Default +28 Vdc**).

2.5.3.13 **VOX**

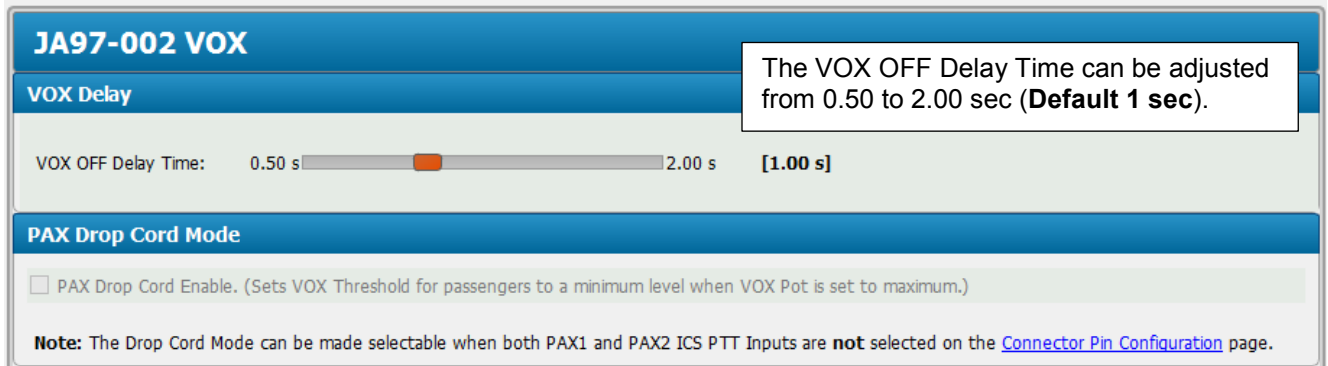

The VOX OFF Delay Time can be adjusted from 0.50 to 2.00 sec (**Default 1 sec**).

When the PAX Drop Cord Enable check box is checked, the VOX circuits for the passenger microphones are configured for use with drop cords (**Default not checked**)

2.5.3.14 **Emergency Radio Selection**

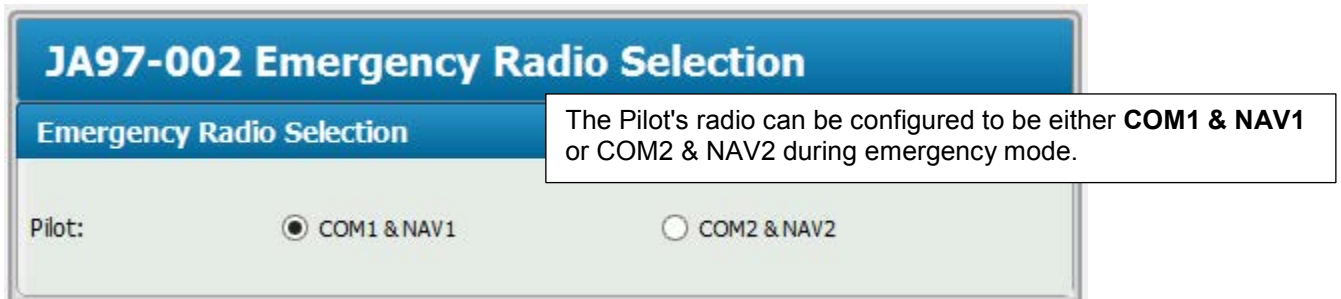

The Pilot's radio can be configured to be either **COM1 & NAV1** or **COM2 & NAV2** during emergency mode.



2.5.3.15 Connector Maps

This section contains connector maps and interconnects that are automatically generated to show changes that affect the installation of the JA97-002, such as switch labels and voltages. See [section 2.7.1](#).

2.5.4 Other Configuration Features

In the JA97-002 Product Information Window, the model number, serial number and check sum of the JA97-002 audio panel can be viewed.

2.6 Installation Kit

The kit required to install this unit is not included with the unit.

The installation kit (Part # INST-JA97) consists of the following:

Quantity	Description	JA97-002
2	TAG ring	CON-5500-0625
1	D-Sub 37-pin connector, hood and 37 crimp pins	CON-3420-0037
1	D-Sub 50-pin connector, hood and 50 crimp pins	CON-3420-0050
2	Heat Shrink Tubing	WIR-HTSK-1000

2.6.1 Recommended Crimp Tools

Standard D-Sub Crimp Tool Chart			
Tool Type	Hand crimping tool	Positioner	Insertion/extractor tool
POSITRONIC	9507-0-0-0	9502-5-0-0	4711-2-0-0
DANIELS	AFM 8	K13-1	91067-2
MIL-SPEC	M22520/2-01	M22520/2-08	M81969/1-02

2.7 Installation Drawings

The drawings and documents required for Installation can be found in [Appendix A](#) of this manual.

2.7.1 Generation of Custom Drawings

The interconnects and connector maps in Appendix A of this manual are generic drawings based on the standard version of the JA97-002. However, if a unit has been configured using JAC's ProCS™ software to change switch legends or lighting voltages, the software can be used to generate fully customized interconnects and connector maps for use by the installer.



SECTION 3 – OPERATION

3.1 Introduction

This section contains the operating instructions for the JA97-002.

3.2 Front Panel Controls



Note: The 15 legends and two deadfront annunciators are removable and may be replaced with custom ordered parts. The front panel controls are referred to by the default legend and annunciator names shown below.

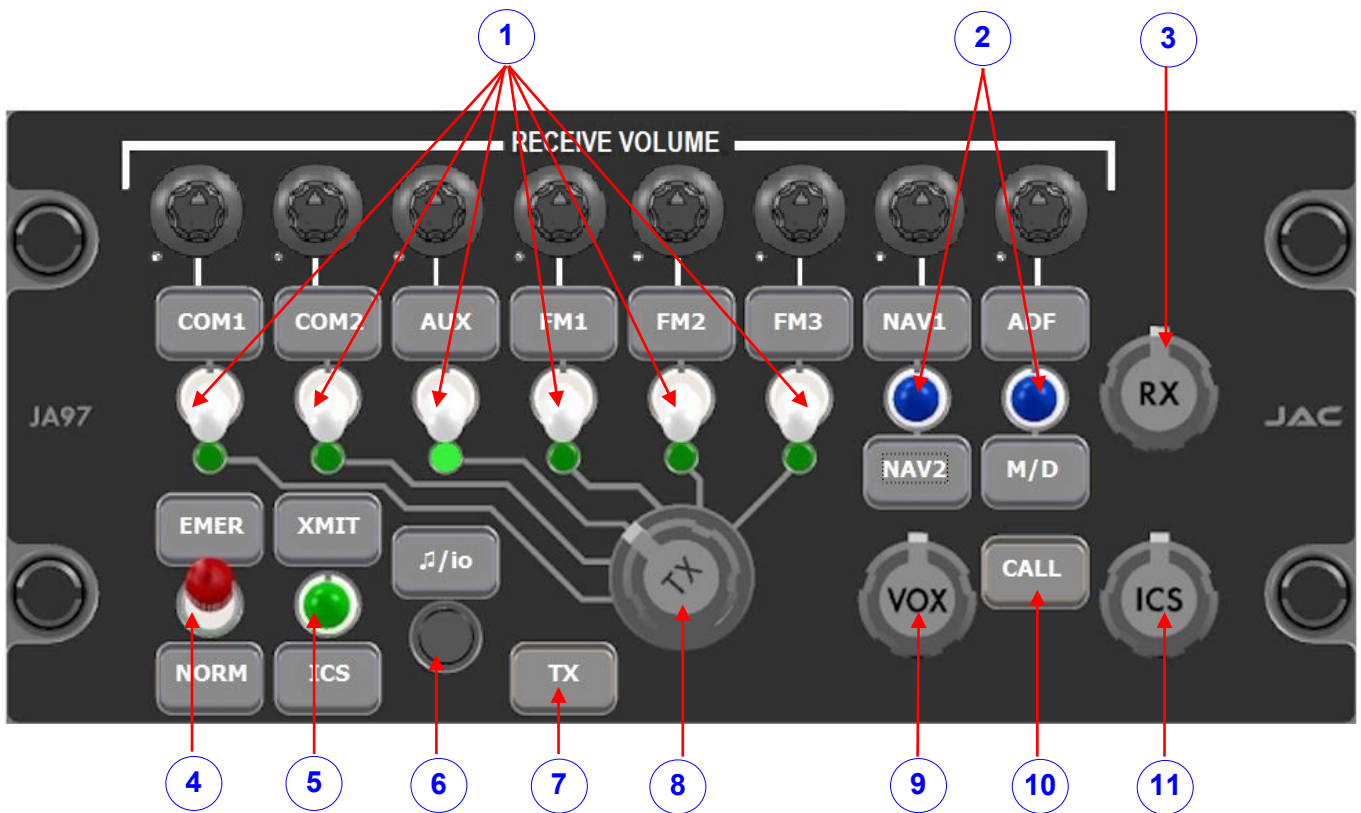

1. Transceiver switches, associated legends and volume controls
2. Receiver switches, associated legends and volume controls
3. Master Receive volume control
4. Mode switch
5. Pilot's Transmit/ICS (Multi-function) switch
6. Music/configuration input connector and legend
7. Transmit annunciator (deadfront)
8. Transmit selector
9. VOX threshold control
10. CALL annunciator (deadfront)
11. ICS volume control



(1) Transceiver Controls and Annunciators

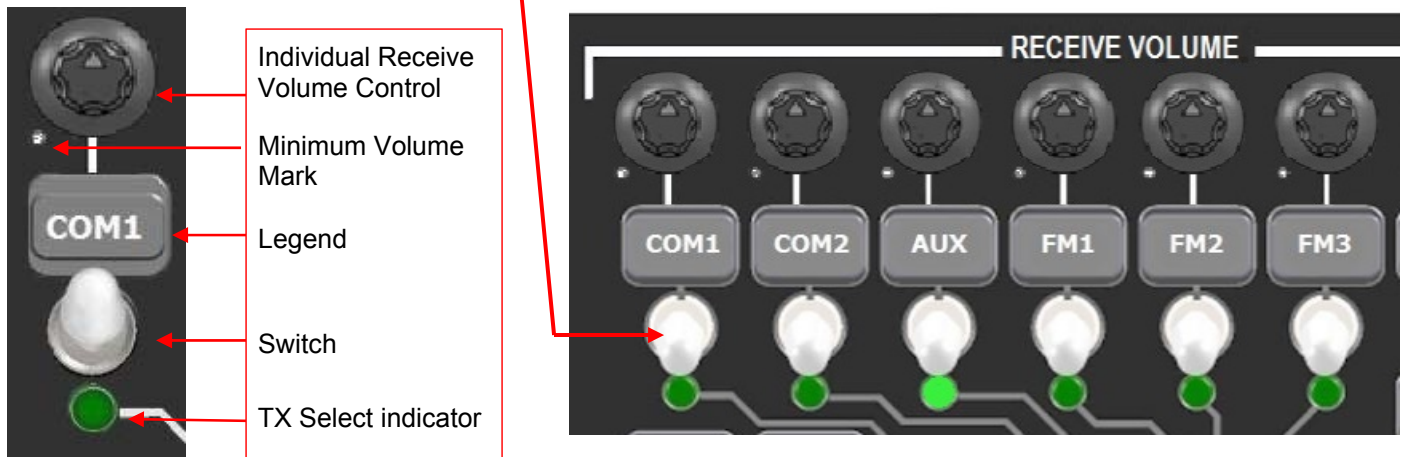

These are six white two-position toggle switches. When a switch is set to the 'up' position (towards the legend), audio from the associated transceiver is routed to the phones.

Each switch has an associated Individual Receive Volume control, and a TX select indicator to show which transceiver is selected for Transmit (AUX in the example above).

The Individual Receive Volume control is a rotary knob that adjusts the individual transceiver phones receive audio volume from minimum (CCW) to maximum (CW).

The legends (above the switches) are interchangeable to allow customization. (Default – COM1, COM2, AUX, FM1, FM2, FM3.)

(2) Receiver Controls and Annunciators

These are two blue three-position centre-off toggle switches. When a switch is set to the 'up' or 'down' position audio from the relevant receiver is routed to the phones. Each switch has an associated Receive Volume control, and an interchangeable legend.

The individual Receive Volume controls are rotary knobs that adjust the individual transceiver phones receive audio volume from minimum (CCW) to maximum (CW). The Individual Receive Volume Control above NAV1 controls the volume for NAV1 and NAV2 and the control above ADF controls the volume for ADF and MKR/DME (M/D.)

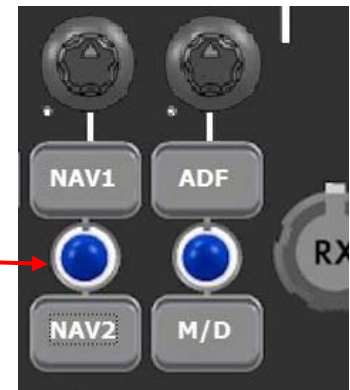

The legends (two above and two below the switches) are interchangeable to allow customization. (Default – NAV1, NAV2, and ADF, M/D.)



Note: When M/D is selected, both MKR and DME audio will be routed to the phones.

(3) Master Receive Volume Control

This is a rotary knob that adjusts the phones volume of all receive audio from minimum (CCW) to maximum (CW). Individual radio volume controls should be set to a nominal level, and then adjusted for changing flight conditions using this control.





(4) Mode Switch

This is a red two-position locking toggle switch. When set to the 'up' position, the unit is Emergency mode, and when set to the 'down' position, the unit is in Normal mode. The legends are interchangeable to allow customization. (Default – EMER, NORM.)

The switch is lockable to prevent accidental changing of the mode. The switch must be lifted to release the lock.

For full information on Emergency and Normal Mode operation, see sections 3.3 and 3.4 below.

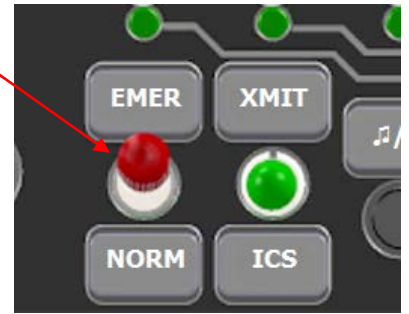

(5) Multi-function (Transmit/ICS) Switch

This is a green two-position centre-off momentary toggle switch.

When in the default XMIT/ICS configuration, this switch acts as the pilot's 'Press-to-talk' (PTT) button. The unit will transmit on the selected transceiver when the switch is held in the 'up' position, and when held in the 'down' position, it will transmit on the intercom.

See section 3.3.7 below for Multi-function Switch operation.

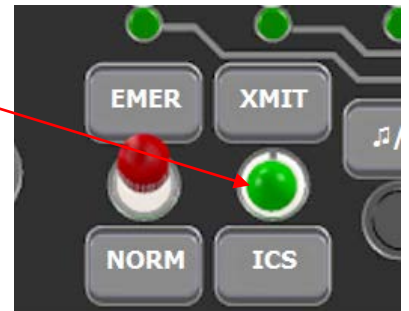

Note: At installation, this switch may be configured to operate in default or alternative mode. Check with your installing agency for confirmation of the operation of this switch. The legends are interchangeable to allow customization.

(6) Music/Configuration Connector (♫/io)

This is a music input that is compatible with most music players. It accepts a 3 pole 3.5mm stereo plug with a slim diameter connector housing.

(This connector is also used during installation to change configuration settings.)



CAUTION: If an unapproved connector or cable is used, damage to the unit or to any attached device may occur. If in doubt, contact JAC for a list of approved cables, music sources and devices.

(7) Transmit Annunciator - TX

This is a deadfront annunciator that will illuminate when the JA97-002 is transmitting.

The default legend is 'TX', but it is interchangeable to allow customization.

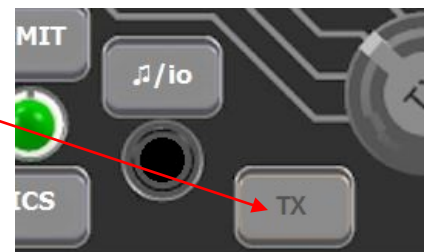

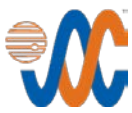

(8) Transmit Selector

This is a rotary six-position control that is used to select transmission via one of the six transceivers.

Each of the transmit selector positions is linked by a white line to the corresponding transmit select annunciator, transceiver switch and legend.

The appropriate annunciator will illuminate to show which transceiver is selected for transmit - 'AUX' in this example.

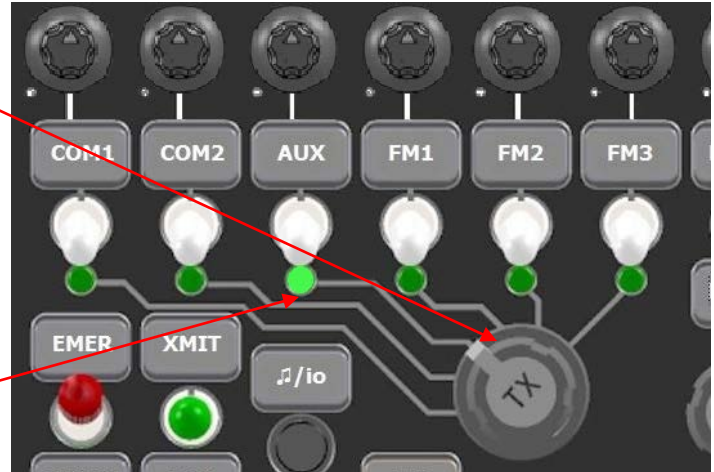

(9) VOX Threshold Control

This is a rotary knob that is used to select the VOX threshold of the unit.

When rotated fully clockwise (CW), the threshold will be at maximum and VOX ICS operation is disabled and ICS PTT input is required for ICS operation.

When rotated fully counterclockwise (CCW), the threshold will be at minimum (almost live).

To adjust the unit for **VOX** (Voice activated) use, the VOX control should be set fully CCW and then slowly rotated CW to the point where no intercom audio can be heard. The VOX control should be adjusted for proper operation with ambient noise.



(10) CALL Annunciator

This is a deadfront annunciator.

When enabled, it will illuminate when a ground is applied to the CALL input from another user's audio controller or by an external 'call' button.

The default legend is 'CALL', but it is interchangeable to allow customization.



Note: Check with your installing agency for confirmation of the operation of this annunciator.

(11) ICS Volume Control

This is a rotary control used to adjust the volume of all ICS audio to suit the ambient conditions. Rotating the control completely CW gives rated level, and completely CCW reduces the output to minimum level.





3.3 Normal Operation Mode



Note: Numbers in parentheses refer to the front panel controls shown in [section 3.2](#).

The JA97-002 is in Normal mode when the front panel EMER / NORM switch (4) is in the NORM position and suitable electrical power is supplied to the unit.

3.3.1 Panel Lighting

The legends and annunciators will be illuminated (when appropriate) and dim through the aircraft lighting buss.

3.3.2 Receiving

When the JA97-002 receives an incoming transmission on a transceiver or receiver that has been selected, either by the white transceiver receive switches (1) or the transmit selector (8), the incoming audio will be directed to the user's phones.

The audio level of incoming transmissions is set by the front panel RX volume control (3). It will be muted if the unit is transmitting and muting of receive audio during transmit is enabled.

3.3.3 Transmitting (Transmit Operation)

To select a transceiver, rotate the Transmit Select Switch until it aligns with the line leading to the Transceiver Select switch legend (see 1) - default legends COM1, COM2, AUX, FM1, FM2, or FM3. The corresponding Transmit Select annunciator will illuminate.

When the user's TX PTT is activated, the unit will transmit on the selected transceiver, and the deadfront Transmit Annunciator (7) will illuminate 'TX'. All MIC and sidetone audio will be routed to the user's phones, and any music will be muted for the duration of the transmission.

3.3.4 FM2 PTT Operation



Note: If the FM2 transceiver has been configured as duplex, it can be used with a cellphone or sat-phone. Check your configuration with the installing agency.

If the unit has been configured for cellphone or sat-phone use and FM2 has been selected for transmit, momentarily activating the TX PTT (either from the faceplate or by some other method) will keep FM2 transmitting. A second momentary activation of the TX PTT, or moving the Transmit Selector away from FM2, will stop FM2 from transmitting.

3.3.5 VOX Operation

A user's MIC audio is routed to the ICS when the MIC audio level exceeds the VOX threshold.

A user's MIC audio is disconnected from the ICS when the MIC audio level falls below the VOX threshold for 0.5 to 2 seconds.

3.3.6 ICS Operation

ICS audio is the sum of all the MIC audio from users with ICS KEY active or with MIC audio level exceeding the VOX Threshold level.

The ICS audio also includes the audio input on the ICS TIE from other audio controllers.

The ICS audio is output on the phones of each user.

The ICS audio is muted during transmit.

The ICS audio level at the phones is controlled by the ICS volume control (12).



3.3.7 Multi-Function (XMIT / ICS) Switch Operation



Note: At installation, this switch may be configured to operate in default or alternative mode. Check with your installing agency for confirmation of the operation of this switch.

Default Operation

When in the default XMIT/ICS configuration, this switch acts as the pilot's 'Press-to-talk' (PTT) button. The unit will transmit on the selected transceiver when the switch is set to the 'up' position, and when set to the 'down' position, it will transmit on the intercom.

Alternative Operation

This switch may be configured to provide a ground signal to operate other equipment.

3.3.8 Music Operation

Music to the phones will be muted by incoming audio (ICS, Receive, Direct or Alert Audio) or if the unit is transmitting. When the incoming audio has ended, the music will gradually return to the previous level.

3.4 Emergency Operation Mode

Emergency mode can be selected by the Mode switch on the front panel, or entered automatically if power to the unit is lost.



CAUTION: At installation, the JA97-002 can be configured for Emergency Mode with the Pilot Headset connected to **COM1 & NAV1** or COM2 & NAV2. It is important to be aware of the configuration of your unit.

3.4.1 Auto Emergency Mode

If the unit is in emergency mode because power has been lost to the unit, the sum of the configured COM transceiver, NAV receive, (**COM1 & NAV1** or COM2 & NAV2) and DIRECT AUDIO will be routed to the pilot's phones and the CVR. The pilot's microphone and transmit key are connected to the configured COM transceiver. No other function in the JA97-002 will operate when power is lost. All indicator LEDs, legends and annunciators will be dark.

3.4.2 Selected Emergency Mode

If the unit is in emergency mode because the EMER / NORM switch is in the EMER position and sufficient power is applied to the JA97-002, the sum of the configured COM receive, NAV receive, DIRECT AUDIO and Alert audio will be routed to the pilot's phones and the CVR. The pilot's microphone and transmit key are connected to the configured COM transceiver. The pilot is disconnected from the ICS. The COM1 transceiver and NAV1 receiver and DIRECT AUDIO are not available to the other users. All other functions of the JA97-002 will operate. The LEDs, legends and annunciators will retain normal functionality.



Installation and Operating Manual

Appendix A - Installation Drawings

A1 Introduction

The drawings necessary for installation and troubleshooting of the JA97-002 Audio Controller with RX Volume Controls are in this Appendix, as listed below.



Note: A fully customized set of Connector Maps and Interconnects can be created using the ProCS software. Refer to the [ProCS™ manual](#) for further information.

A2 Installation Drawings

DOCUMENT	Rev
JA97-002 Connector Map	A
JA97-002 Interconnect	A
JA97-002 Mechanical Installation	B

Reference Documents	
TOL-CUST-EXTR Legend Replacement	A

RECEIVE CONNECTOR

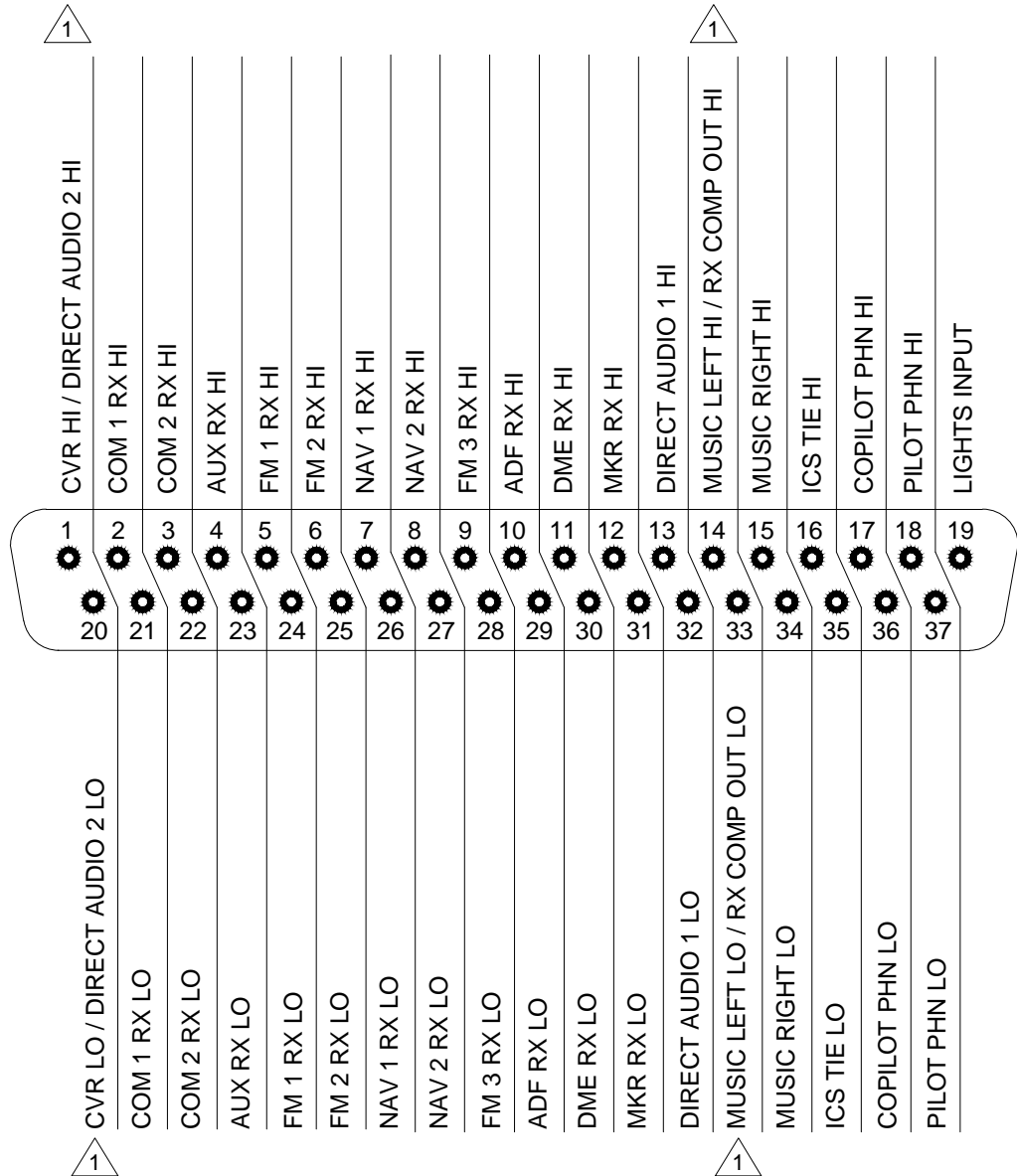

P1
37 PIN FEMALE DMIN
MATING CONNECTOR



VIEW IS FROM REAR OF MATING CONNECTOR

NOTE:

△ CONFIGURABLE CONTACT

PREPARED	TAT			
CHECKED				
APPROVED		TITLE Audio Controller with RX Volume Controls P1 Connector Map		
CONFIDENTIAL & PROPRIETARY TO JUPITER AVIONICS CORP.				
		DOC NO. JA97-002 Connector Map Rev A.dwg		

TRANSMIT CONNECTOR

P2

50 PIN FEMALE DMIN
MATING CONNECTOR

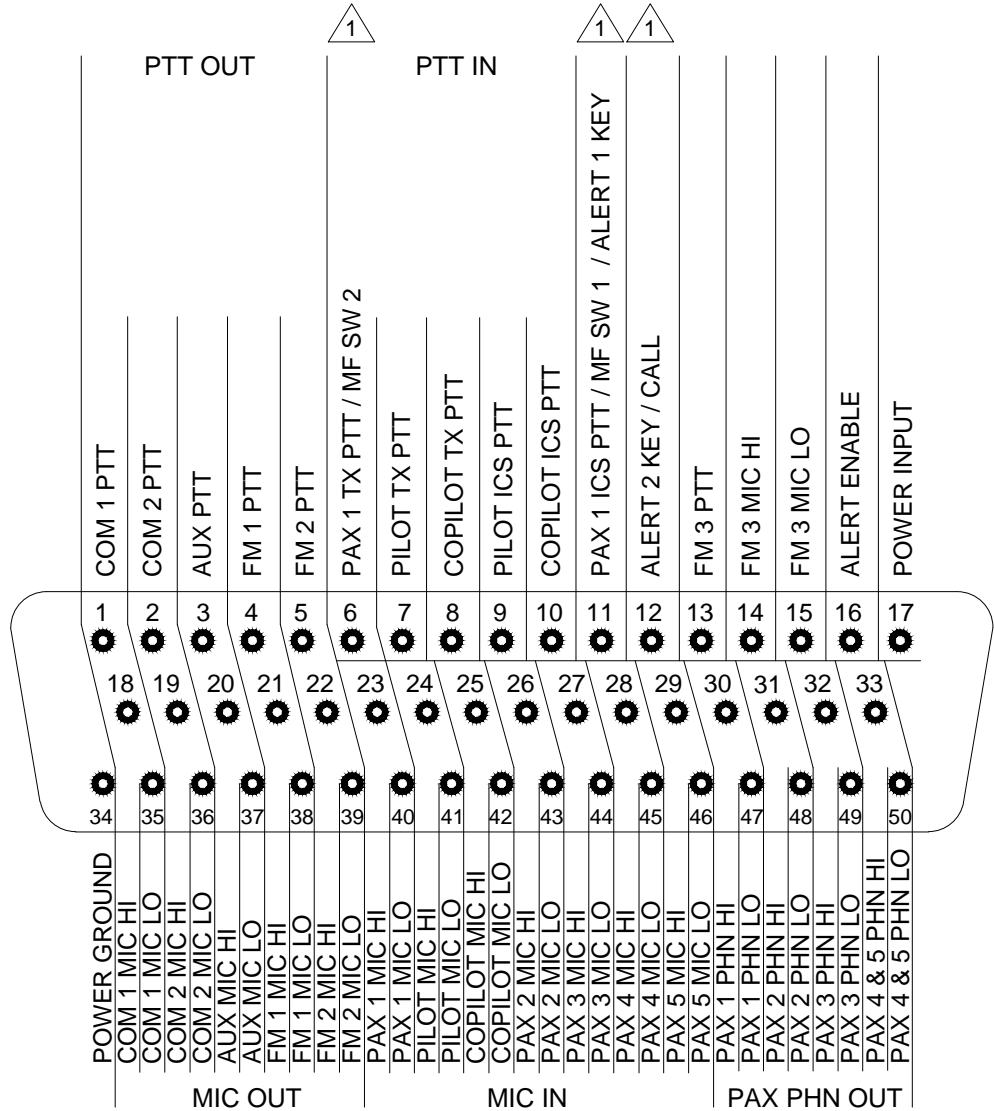

VIEW IS FROM REAR OF MATING CONNECTOR

PREPARED	TAT	JUPITER AVIONICS CORPORATION		
CHECKED				
APPROVED		NCAGE CODE L00N3	PART NO. JA97-002	SHEET 2/3
CONFIDENTIAL & PROPRIETARY TO JUPITER AVIONICS CORP.		DOC NO. JA97-002 Connector Map Rev A.dwg		

FRONT PANEL MUSIC/CONFIGURATION CONNECTOR

P3

ACCEPTS THE FOLLOWING PLUG FORMATS

MATING PLUG NAMES

JA97 SIGNAL NAMES

JA99 CONFIGURATION CABLE
4 POLE MALE 3.5MM STEREO

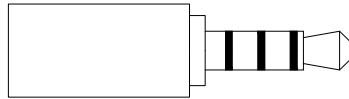

TIP: TX DATA
1ST RING: RX DATA
2ND RING: GROUND
3RD RING: CONFIG AUDIO

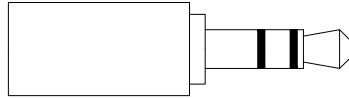

CONFIG DATA TO JA97
CONFIG DATA FROM JA97
GROUND
MODE SELECT / CONFIG AUDIO

MP3 STEREO PLAYER,
IPHONE 3GS OR 4
3 POLE MALE 3.5MM STEREO



TIP: LEFT MUSIC
1ST RING: RIGHT MUSIC
2ND RING: GROUND

FRONT PANEL MUSIC LEFT
FRONT PANEL MUSIC RIGHT
GROUND

PREPARED	TAT			
CHECKED		TITLE Audio Controller with RX Volume Controls P3 Connector Map		
APPROVED		NCAGE CODE L00N3	PART NO. JA97-002	SHEET 3/3
CONFIDENTIAL & PROPRIETARY TO JUPITER AVIONICS CORP.		DOC NO. JA97-002 Connector Map Rev A.dwg		

JA97-002 INTERCONNECT WIRING NOTES



NOTES

1. ALL WIRE SIZE SHOULD BE 24 AWG MIN UNLESS OTHERWISE SPECIFIED. UNSHIELDED WIRE SHOULD BE SELECTED PER FAA AC43.13-1B CHANGE 1 PARA 11-76 TO 11-78. WIRE TYPES SHOULD BE IN ACCORDANCE WITH MIL-W-22759 AS DESCRIBED IN FAA AC43.13-1B CHANGE 1 PARA 11-85 AND 11-86 AND LISTED IN TABLE 11-11 OR 11-12. ALL SHIELDED CABLE SHOULD BE IN ACCORDANCE WITH MIL-DTL-27500 (REVISION H OR LATER).
2. CONNECTION TO AIRFRAME GROUND SHOULD BE MADE WITH 20 AWG WIRE. LENGTH NOT TO EXCEED 3 FT (0.9 M).
3. CABLE SHIELDS AT THE JA97-002 CONNECTOR PINS SHOULD BE TERMINATED TO AIRFRAME GROUND USING A TAG RING P/N: MS27741-5 OR EQUIVALENT.
4. CONNECTOR PIN HAS MORE THAN ONE FUNCTION. SEE THE OPTIONS SECTION OF THIS DRAWING FOR ALTERNATE INTERCONNECT WIRING.
5. ONLY +28 VDC OR +14 VDC OR +5 VDC LIGHTS INPUT VOLTAGE MAY BE APPLIED AT ONE TIME.
6. THE FRONT PANEL MUSIC INPUT SHALL NOT BE CONNECTED TO ANY OTHER AUDIO INPUT.
7. THE DIRECT AUDIO 2 SHALL NOT BE WIRED IN PARALLEL WITH ANY OTHER AUDIO INPUT. THE DIRECT AUDIO 2 INPUT IS BEST SUITED FOR AUDIO SIGNALS THAT ARE TO BE ROUTED TO THE PILOT PHONES WHEN IN EMERGENCY MODE.

CONNECTOR PIN LEGENDS

LEGEND

RESERVED INTERNAL CIRCUITS MAY EXIST AND MAY BE ACTIVATED FOR FUTURE USE. NO EXTERNAL WIRE CONNECTION.



PREPARED	TAT			
CHECKED				
APPROVED		NCAGE CODE PART NO. L00N3 JA97-002		SHEET 1/6
CONFIDENTIAL & PROPRIETARY TO JUPITER AVIONICS CORP.		DOC NO. JA97-002 Interconnect Rev A.dwg		

JA97-002

J1

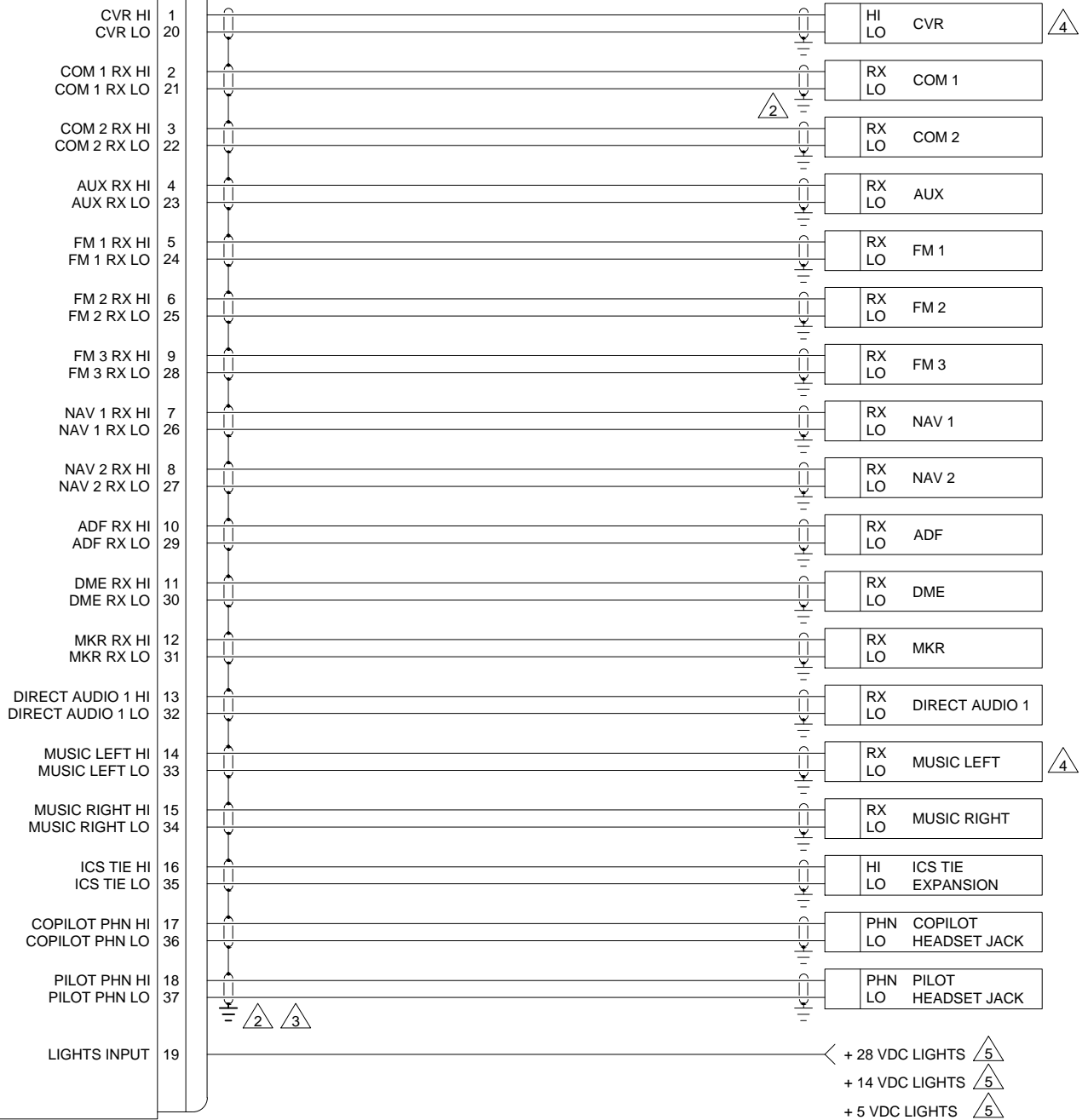
P1
37 PIN FEMALE DMIN
MATING CONNECTOR







PREPARED	TAT			
CHECKED				
APPROVED		NCAGE CODE L00N3	PART NO. JA97-002	SHEET 2/6
CONFIDENTIAL & PROPRIETARY TO JUPITER AVIONICS CORP.		DOC NO. JA97-002 Interconnect Rev A.dwg		

JA97-002

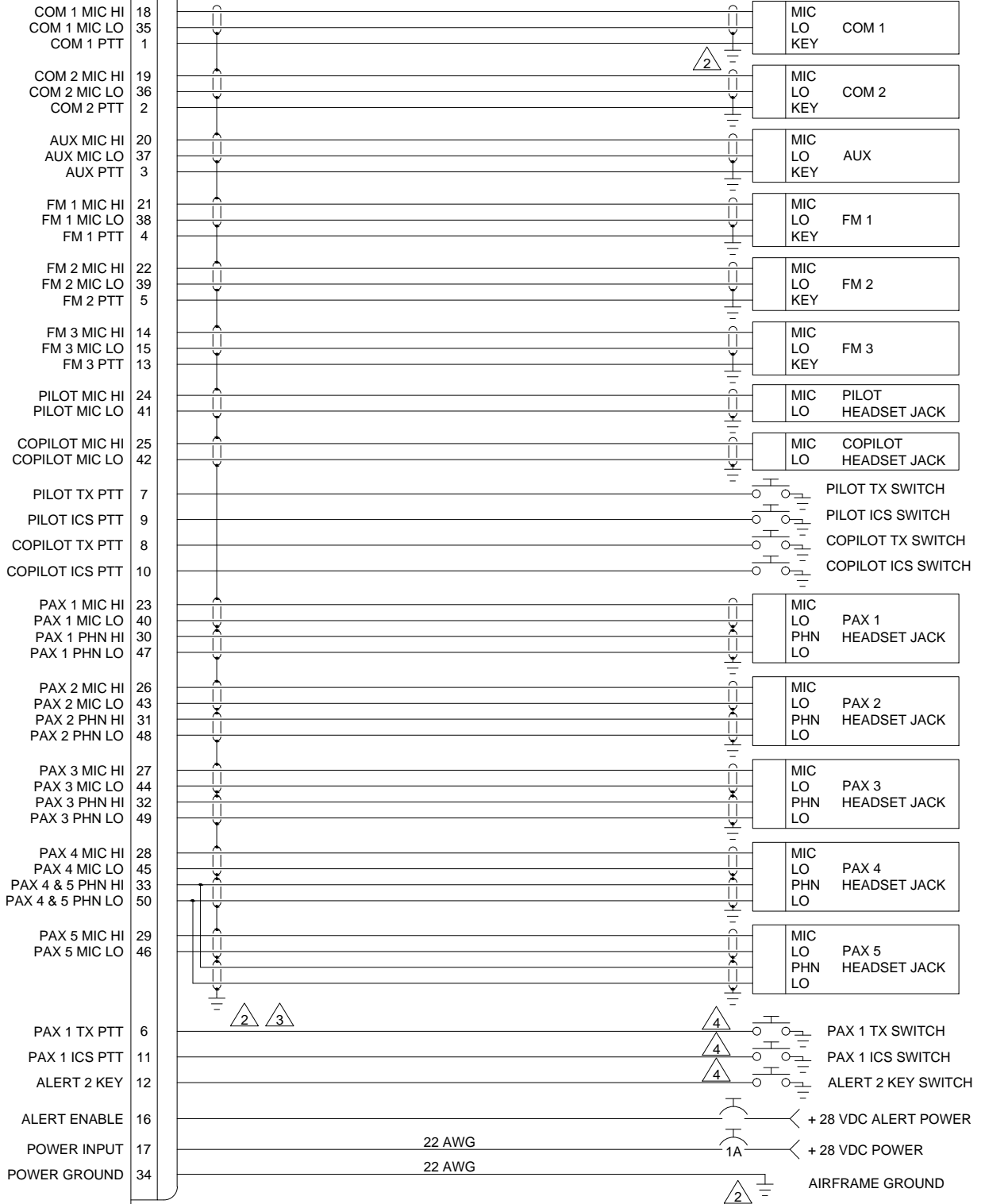
J2

P2
50 PIN FEMALE DMIN
MATING CONNECTOR





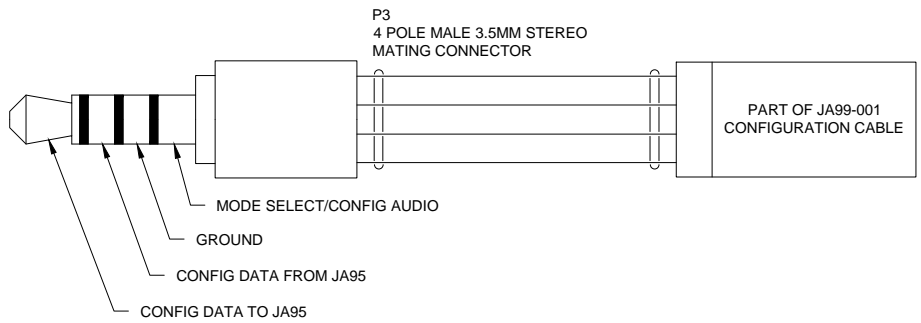
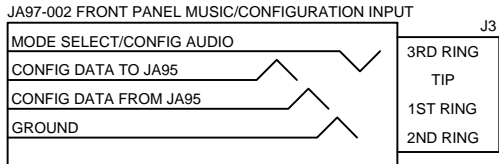

PREPARED	TAT			
CHECKED				
APPROVED		NCAGE CODE L00N3	PART NO. JA97-002	SHEET 3/6
CONFIDENTIAL & PROPRIETARY TO JUPITER AVIONICS CORP.		DOC NO. JA97-002 Interconnect Rev A.dwg		

OPTION: PROGRAMMING FROM JA99-001

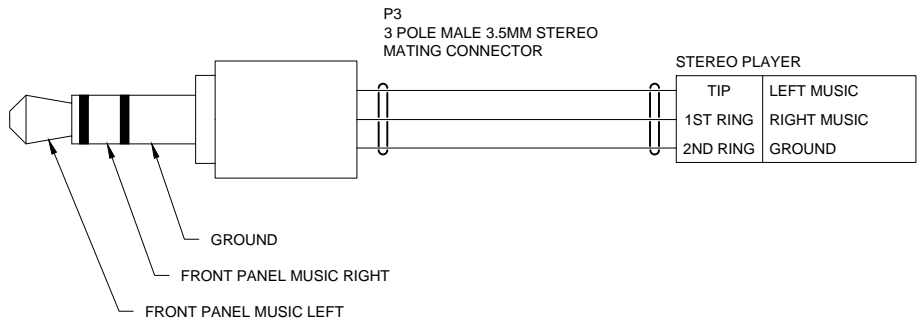
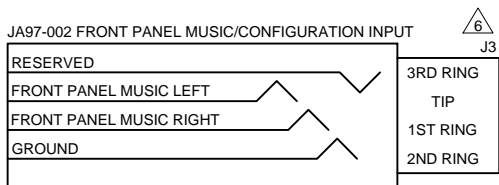

OPTION: STEREO PLAYER



PREPARED	TAT			
CHECKED				
APPROVED		NCAGE CODE L00N3	PART NO. JA97-002	SHEET 4/6
CONFIDENTIAL & PROPRIETARY TO JUPITER AVIONICS CORP.		DOC NO. JA97-002 Interconnect Rev A.dwg		

OPTION: DIRECT AUDIO 2 IN

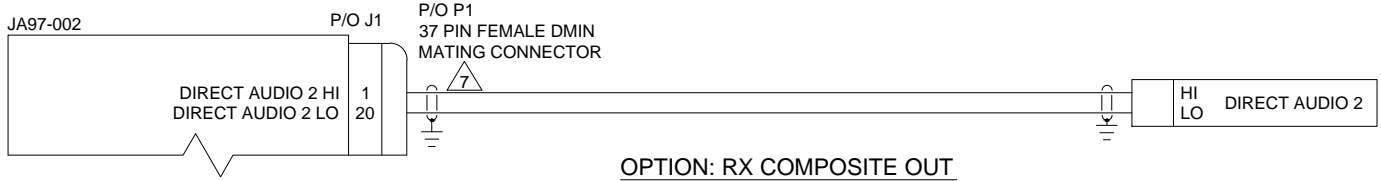

OPTION: RX COMPOSITE OUT

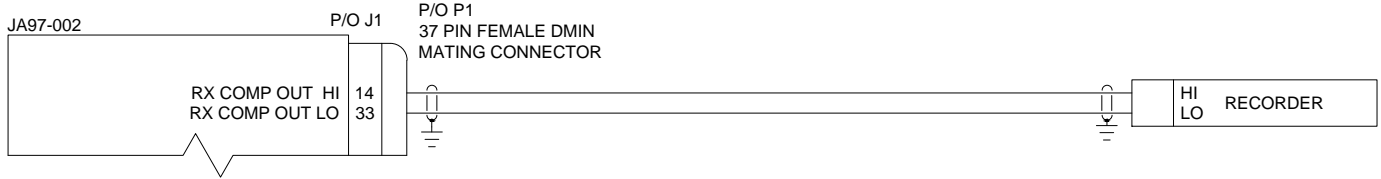

OPTION: MULTI-FUNCTION SWITCH OUTPUTS (MF SW 1 & MF SW 2)

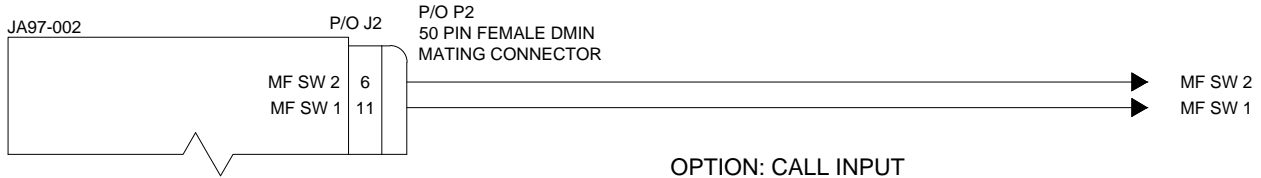

OPTION: CALL INPUT

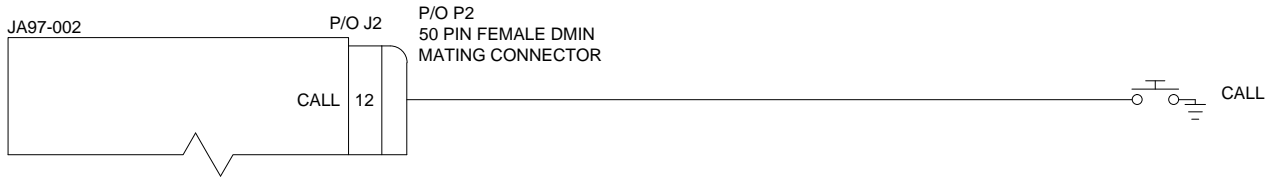

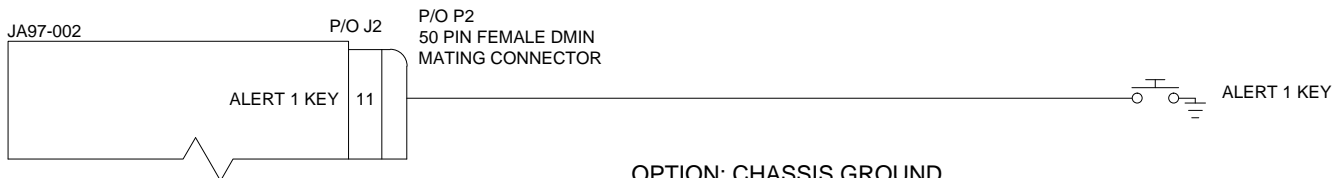

OPTION: CONFIGURABLE SWITCH INPUTS (ALERT 1 KEY)



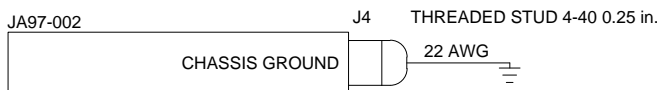



OPTION: CHASSIS GROUND



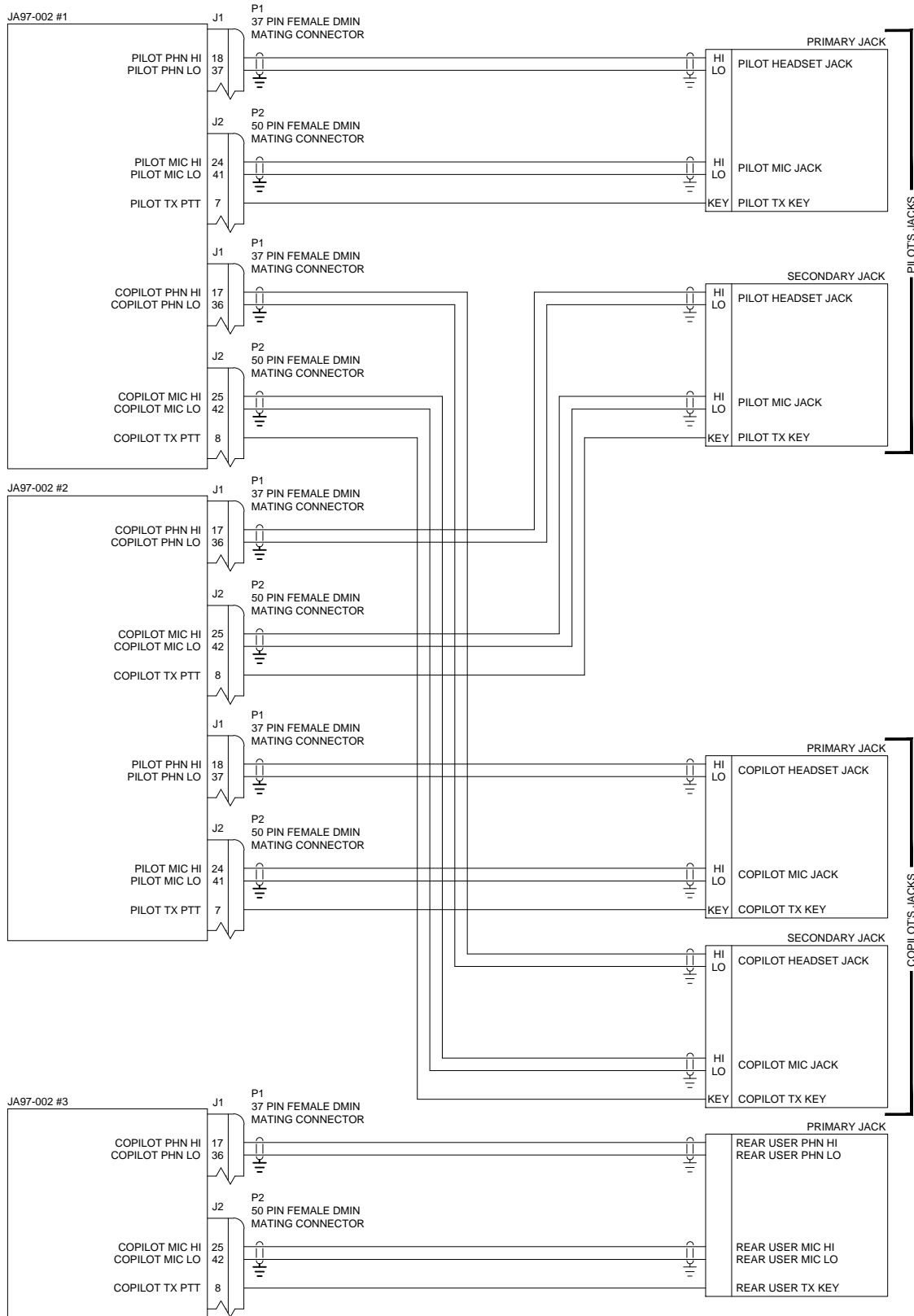

PREPARED	TAT			
CHECKED				
APPROVED		Audio Controller with RX Volume Controls Interconnect Options		SHEET
CONFIDENTIAL & PROPRIETARY TO JUPITER AVIONICS CORP.		NCAGE CODE L00N3	PART NO. JA97-002	5/6
		DOC NO. JA97-002 Interconnect Rev A.dwg		

OPTION: MULTIPLE AUDIO CONTROLLER INSTALL

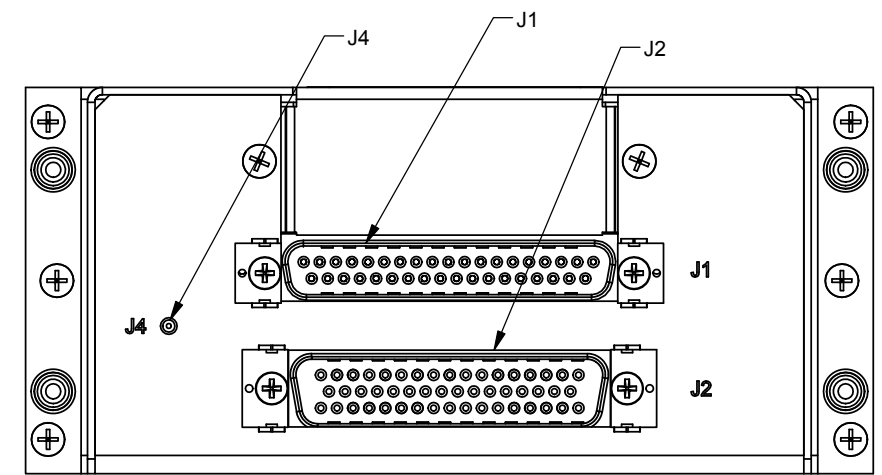
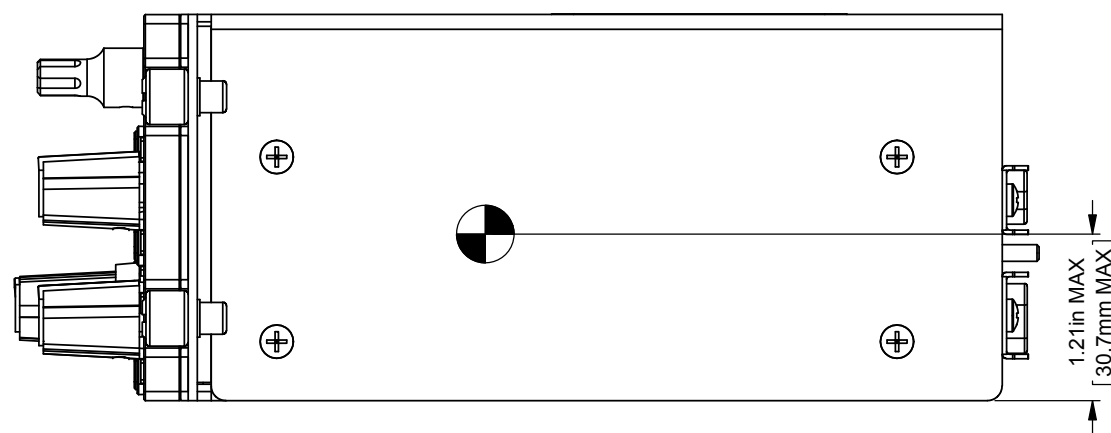
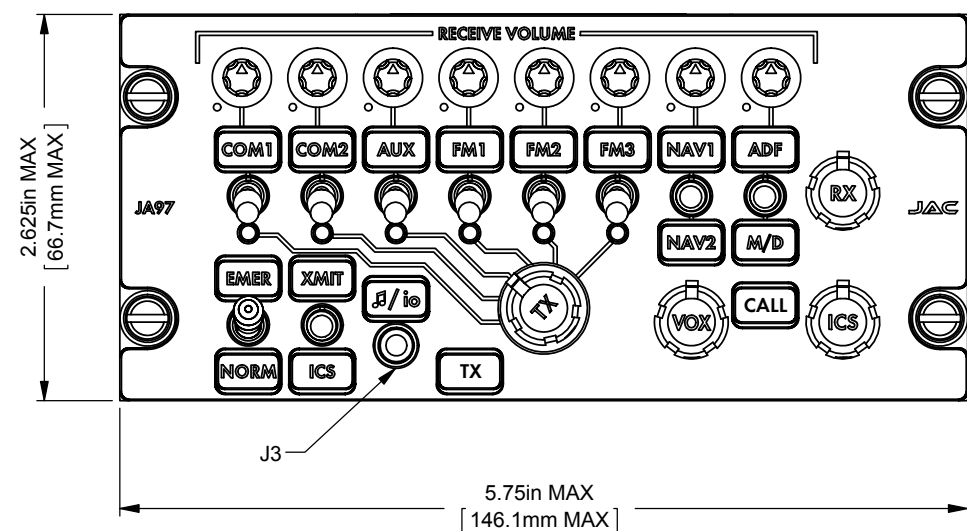
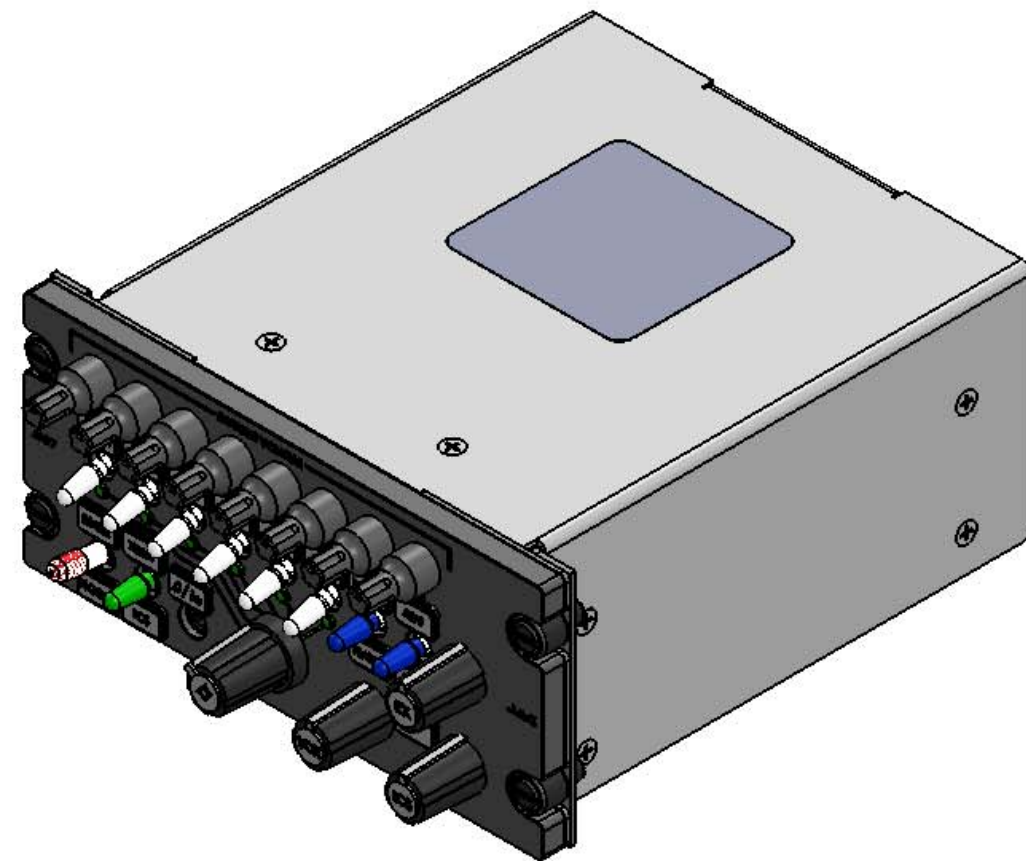
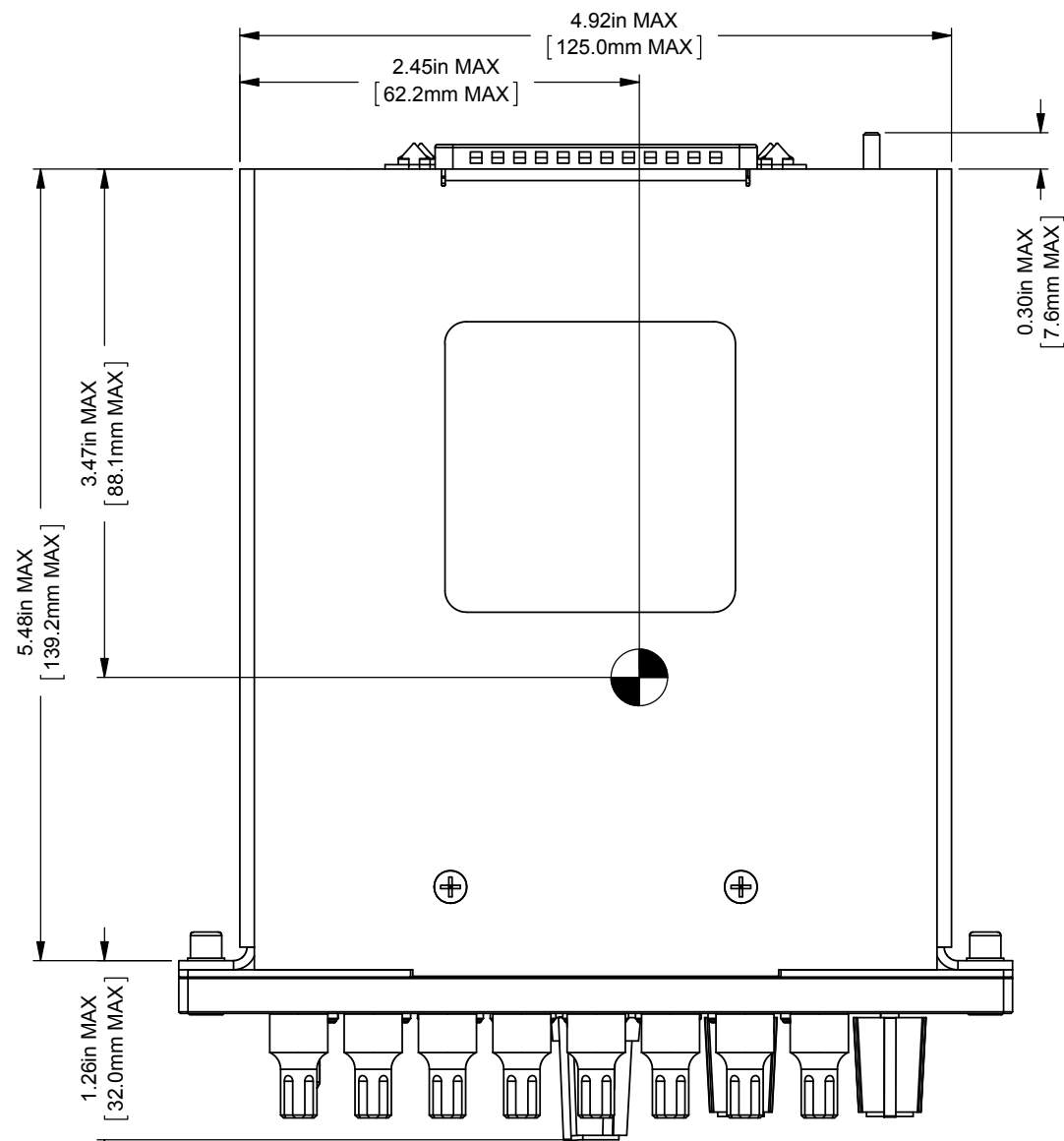

PREPARED	TAT			
CHECKED				
APPROVED		Audio Controller with RX Volume Controls Multiple Audio Controller Option		
CONFIDENTIAL & PROPRIETARY TO JUPITER AVIONICS CORP.		NCAGE CODE L00N3	PART NO. JA97-002	SHEET 6/6
		DOC NO. JA97-002 Interconnect Rev A.dwg		



 CENTER OF GRAVITY
 ±0.03in [0.8mm]
 WEIGHT: 2.23 lbs [1.01 kg] MAX.

UNLESS OTHERWISE SPECIFIED
 DIMENSIONS ARE IN INCHES
 ANGLES ARE IN DEGREES
 TOLERANCES:
 1 DEC PLACE: ± 0.1
 2 DEC PLACE: ± 0.01
 3 DEC PLACE: ± 0.005
 ANGLES: ± 0.5 DEG

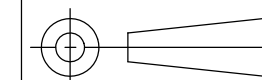

MATERIAL: N/A
 FINISH: N/A

PREPARED	TAT
CHECKED	JAC 05-16-16 DS
APPROVED	JAC 05-16-16 KDV
CONFIDENTIAL & PROPRIETARY TO JUPITER AVIONICS CORP. DRAWING NOT TO SCALE	

		TITLE	
		Audio Controller with RX Volume Controls	
NCAGE CODE	PART NO.	SHEET	
L00N3	JA97-002	1/1	
DOC. NO.		JA97-002 Mechanical Installation Rev B.SLDDRW	



Field-Replaceable Legends

Jupiter Avionics Corporation (JAC) products have field-replaceable illuminated legends. This permits easy customization, and allows the same units to be used in multiple different configurations with only minimal changes.

The internal circuitry ensures that, although the legends are individually illuminated, the illumination is consistent and uniform throughout all legends, and never needs to be balanced. This means that if it is a requirement to change the labelling due to damage or for a different project, there is no need for costly and time-consuming illumination checks.

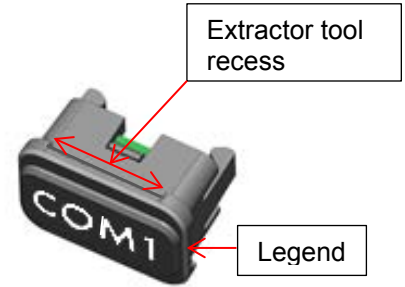

Legend Removal



Caution: Take care not to scratch or otherwise damage the faceplate or the legend.

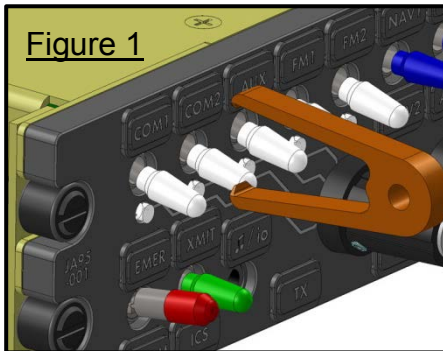

Figure 1

To facilitate legend removal, JAC provides a legend extractor tool - part # TOL-CUST-EXTR (figure 1) that fits into the recesses on the legend.

To remove a legend, hold the extractor firmly between the forefinger and thumb, and use a tweezer-like action to grip the legend (figure 2).

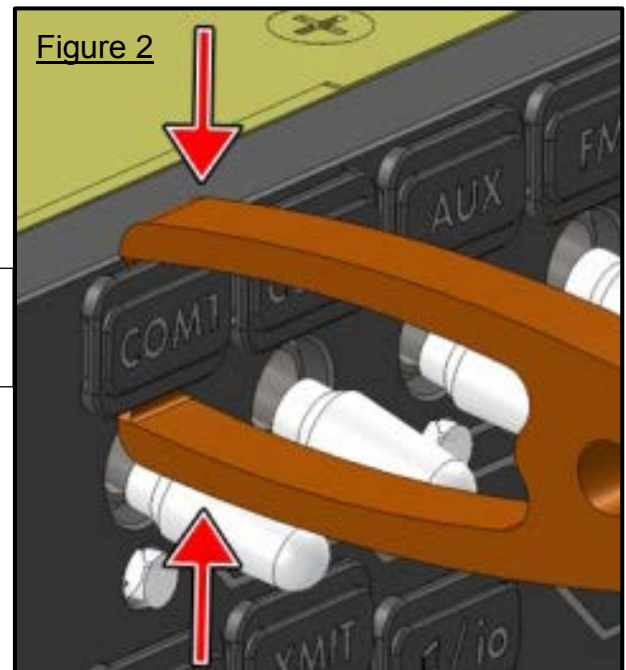

Figure 2

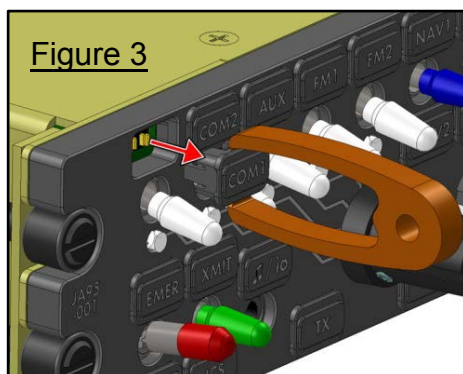

Figure 3

Pull the legend away from the faceplate as shown in figure 3.

Legend Replacement

To replace a legend, align the text correctly, and then apply gentle pressure until the body of the legend support seats firmly into the faceplate.

Once the new legend is in place, ensure that it has seated correctly by checking that it illuminates. The unit is now ready for use.



Installation and Operating Manual

Appendix B - Installation Documents

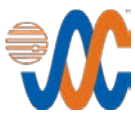

B1 Airworthiness Approval

Airworthiness approval of the JA97-002 may require completion of a TCCA Major Modification Report per CAR STD (AWM) 571 Appendix L, or a FAA Form 337. The sample wording for a description of the work is provided to assist the Installing Agency in preparing Instructions for Continued Airworthiness (ICA) when replacing an existing audio panel with a Jupiter Avionics JA97-002 Audio Controller with RX Volume Controls. This sample may be modified appropriately for new installations. It is the installer's responsibility to determine the applicability of the method used. Installations performed outside Canada must follow the applicable aviation authority's regulations.

Sample Wording:

Removed the existing [model] audio panel and replaced with a Jupiter Avionics JA97-002 Audio Controller with RX Volume Controls in [aircraft location].

See Section 1 of the JA97-002 Installation Manual.

Installed in accordance with the JA97-002 Installation Manual, Revision [], and AC 43.13-2, Chapters 2, and 3.

The JA97-002 interfaces with existing aircraft systems per the Installation Manual instructions.

The JA97-002 Installation Manual provides detailed installation instructions and wiring diagrams (Section 2, and Appendices A and B).

Power is supplied to the JA97-002 through an existing []-Amp circuit breaker that was previously used by the original audio panel. The net electrical load is unchanged.

Aircraft equipment list, weights and balance amended. Compass compensation checked and found to conform to applicable regulations.

B2 Instructions for Continued Airworthiness

Maintenance of the JA97-002 Audio Controller with RX Volume Controls is "on condition" only. Refer to the JA97-002 Maintenance Manual. Periodic maintenance of the JA97-002 is not required.

The following sample Instructions for Continued Airworthiness (ICA) provides assistance in preparing ICA for the Jupiter Avionics JA97-002 unit installation as part of a Type Certificate (TC) or Supplemental Type Certificate (STC) project to comply with CAR STD (AWM) 523/527/525/529.1529 or FAR 23/25/27/29.1529 "Instructions for Continued Airworthiness".

Items that may vary by aircraft make and model are shown in brackets ("[]") and should be filled in as appropriate. Some of the checklist items do not apply, in which case they should be marked "N/A" (Not Applicable).

Instructions for Continued Airworthiness, Jupiter Avionics JA97-002 Audio Controller with RX Volume Controls in an [Aircraft Make and Model]

1. Introduction

[Aircraft that has been altered: Registration number, Make, Model and Serial Number]

Content, Scope, Purpose and Arrangement: This document identifies the Instructions for Continued Airworthiness for a Jupiter Avionics JA97-002 installed in an [aircraft make and model].

Applicability: Applies to a Jupiter Avionics JA97-002 installed in an [aircraft make and model].

Definitions/Abbreviations: None, N/A.

Precautions: None, N/A.

Units of Measurement: None, N/A.

Referenced Publications: JA97-002 Installation and Operating Manual
JA97-002 Maintenance Manual
JA97-002 Operating Manual
STC/TC # [applicable STC/TC number for the specific aircraft installation]

Distribution: This document should be a permanent aircraft record.

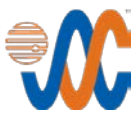

2. Description of the System/Alteration

Jupiter Avionics JA97-002 Audio Controller with RX Volume Controls with interface to external transceivers and [include other equipment/systems as appropriate]. Refer to Appendix A of this manual for interconnect information. Refer to aircraft manufacturer approved interconnect for actual installation.

3. Control, Operation Information

Refer to section 3 of this manual or to the Jupiter Avionics JA97-002 Operating Manual.

4. Servicing Information

N/A

5. Maintenance Instructions

Maintenance of the JA97-002 is 'on condition' only. Periodic maintenance is not required. Refer to the JA97-002 Maintenance Manual.

6. Troubleshooting Information

Refer to the JA97-002 Maintenance Manual.

7. Removal and Replacement Information

Refer to Section 2 of this manual - the JA97-002 Installation and Operating Manual. If the unit is removed and reinstalled, a functional check of the equipment should be conducted.

8. Diagrams

Refer to Appendix A of this manual - the JA97-002 Installation and Operating Manual - for installation drawings and interconnect examples.

9. Special Inspection Requirements

N/A

10. Application of Protective Treatments

N/A

11. Data: Relative to Structural Fasteners

JA97-002 and appropriate mounting hardware installation, removal and replacement should be in accordance with applicable provisions of AC 43.13-1B and AC 43.13-2A.

12. Special Tools

N/A

13. This Section is for Commuter Category Aircraft Only

A. **Electrical loads:** Refer to Section 1 of the JA97-002 Installation and Operating Manual.

B. **Methods of balancing flight controls:** N/A.

C. **Identification of primary and secondary structures:** N/A.

D. **Special repair methods applicable to the airplane:** N/A.

14. Overhaul Period

No additional overhaul time limitations.

15. Airworthiness Limitation Section

N/A