

KFC 225

Bendix/King® Automatic Flight Control System



WARNING

The enclosed technical data is eligible for export under License Designation NLR and is to be used solely by the individual/organization to whom it is addressed. Diversion contrary to U.S. law is prohibited.

COPYRIGHT NOTICE

Copyright ©1999, 2004 Honeywell International Inc.
All rights reserved.

Reproduction of this publication or any portion thereof by any means without the express written permission of Honeywell International Inc. is prohibited. For further information contact the Manager, Technical Publications; Honeywell; One Technology Center; 23500 West 105th Street; Olathe, Kansas 66061. Telephone: (913) 712-0400.

Revision History and Instructions

Manual KFC 225 AFCS Pilot's Guide

Revision 1, September 2004

Part Number 006-18035-0000

This revision incorporates a note further explaining the Altitude Hold function.

The following pages were changed:

Front Cover, Copyright, 9, 13, Back Cover

Revision History and Instructions

Manual KFC 225 AFCS Pilot's Guide

Revision 0, April 1999

Part Number 006-18035-0000

This is the original version of this publication.

Introduction	1
General Description	2
System Integration	2
Power Application and Preflight Tests	4
KFC 225 System Operation	5
Controls and Displays Operation	5
Altitude Alerting and Preselect	10
Altitude Alerter	10
Altitude Preselect	10
Voice Messaging	11
System Operating Modes	12
Pitch and Roll Attitude Hold (PIT) Modes	12
Altitude Hold (ALT) Mode	13
KFC 225 Detailed System Operation	14
Takeoff And Climb To Assigned Altitude	14
GPS Capture	16
Outbound On Front Course For Procedure Turn To ILS Approach	18
Front Course ILS Approach	20
Outbound on GPS Approach	22
Inbound on GPS Approach	24
KCS 55A Compass System	27
KI 525A Indicator	28
Description of Indicator and Display Functions	28
Slaving Meter (KA 51B)	30
KMT 112 Magnetic Slaving Transmitter	31
KG 102A Directional Gyro	31
Abnormal Circumstances	33
Flight Procedures with the KCS 55A	34
General Emergency Procedures	41
Autopilot Malfunction	41

Table of Contents

This page intentionally left blank

Introduction

The pressures of single-pilot instrument flying place critical demands on the skill and concentration of any pilot. To aid you in meeting these challenges, Honeywell has developed the KFC 225 Flight Control System. This system places recent flight control advances normally found only in high end 'jet' autopilots into the cockpits of General Aviation Aircraft.

The heart of the system is a lightweight, integrated autopilot computer combining the functions of computer, mode selector, altitude pre-selector, and the optional yaw damper into one unit. The system has been designed to work with your Bendix/King equipment from day one. It can interface directly with your EFIS system, take roll steering commands from your KLN 90B IFR GPS, and, when available, listen to your KRA 10A radar altimeter to improve approach tracking.

It is significant that this Silver Crown Plus flight control system has been designed from the beginning to interface with your Silver Crown Plus package of avionics. Consider the advantage of having your avionics working together as an integrated system rather than as a group of unrelated components built by several different manufacturers.

To fully utilize the impressive capabilities of this full-featured system it is important that the pilot understand the capabilities and limitations of the system. The pilot should take time to read and thoroughly understand the FLIGHT MANUAL SUPPLEMENT for the autopilot installation specific to his aircraft. This Pilot's Guide should be used to gain additional insight into the operation of the system through the specific operating scenarios. The FLIGHT MANUAL SUPPLEMENT information shall always take precedence over the information found in this manual.

Introduction

General Description

The KFC 225 Three Axis system provides lateral, vertical and optional yaw modes with altitude preselect.

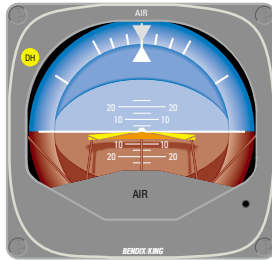

System Integration

The system diagram on the next page shows the components and their relationship in a typical KFC 225 system. The actual components on individual systems may vary slightly depending on certification and installation requirements.

The system diagram reflects that the KFC 225 system controls pitch, roll and yaw (optional) axes of the aircraft.

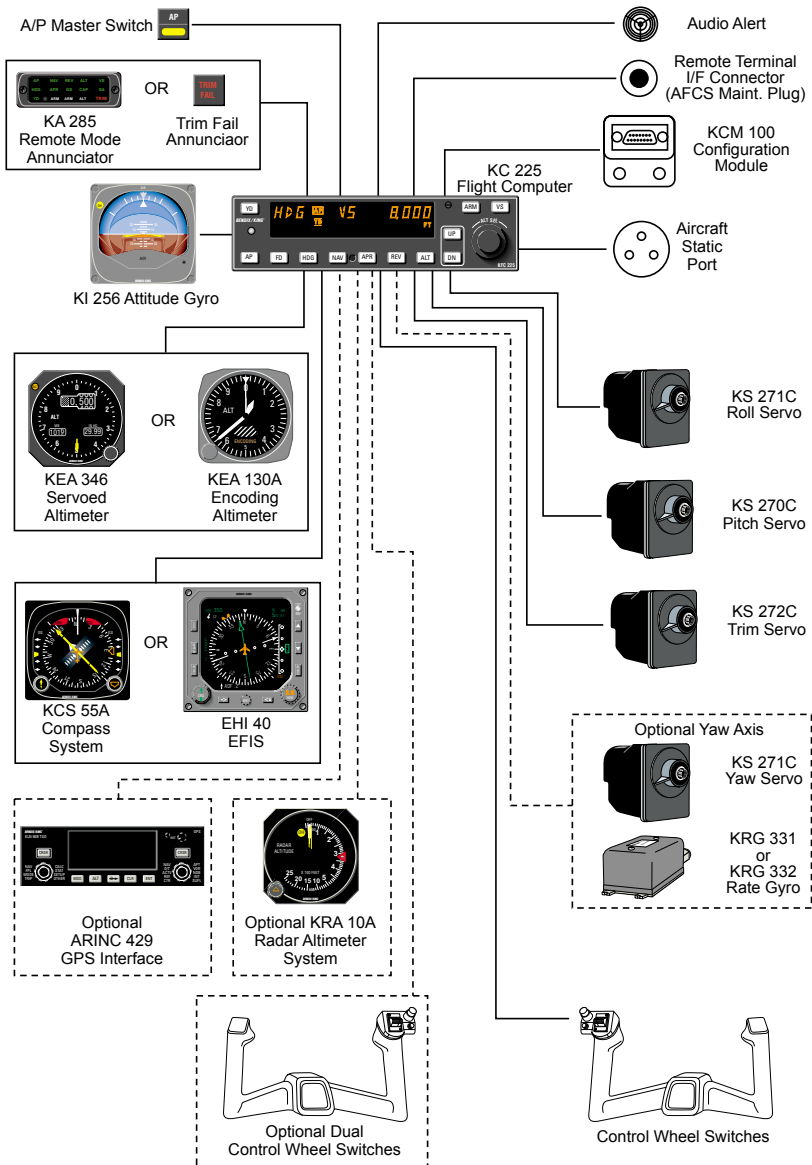

KFC 225 System Diagram

Power Application and Preflight Tests



KFC 225 Preflight Test



KFC 225 Preflight Test Complete

A preflight test is performed upon power application to the computer. This test is a sequence of internal checks that validate proper system operation prior to allowing autopilot engagement. The preflight test (PFT) sequence is indicated by "PFT" with an increasing number for the sequence steps. Successful completion of self test is identified by all display segments being illuminated (Display Test), the Flight Director command bars brought into view and the disconnect tone sounding.

NOTE: Following the preflight test, the red P warning on the face of the autopilot may illuminate indicating that the pitch axis cannot be engaged. This condition should be temporary, lasting no more than 30 seconds. The P will extinguish and normal operation will be available.

KFC 225 System Operation

Controls and Displays Operation

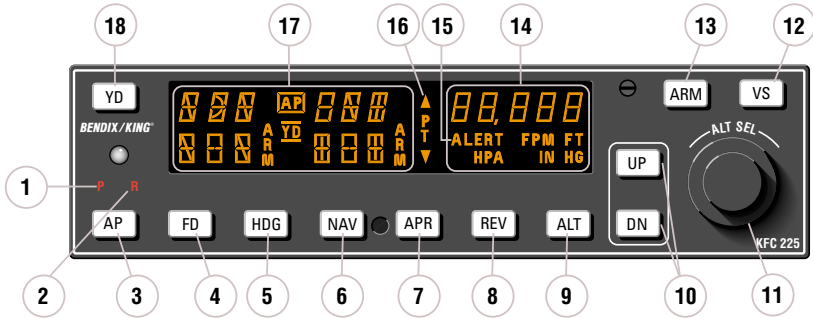

Full KFC 225 Three-Axis with Altitude Preselect Display

- PITCH AXIS, (P) ANNUNCIATOR** - When illuminated, indicates failure of the pitch axis and will lead to disengagement of the autopilot. (Will also illuminate during short term vertical accelerations in excess of +1.6g or less than +0.4g which may not cause autopilot disengagement.)
- ROLL AXIS (R) ANNUNCIATOR** - When illuminated, indicates failure of the roll axis and will disengage the autopilot.
- AUTOPILOT ENGAGE/DISENGAGE (AP) BUTTON** - When pressed, engages the flight director, autopilot and yaw damper (if installed). If the flight director is not already engaged, the system will engage into the basic wings level (ROL) and pitch (PIT) attitude hold modes. The pitch attitude maintained will be the pitch attitude present at the moment of AP button press. When pressed again, will disengage the autopilot.
- FLIGHT DIRECTOR (FD) MODE SELECTOR BUTTON** - When pressed will engage the flight director into the basic roll (ROL) mode which functions as a wing leveler, and into the pitch attitude (PIT) hold mode. The pitch attitude maintained will be the pitch attitude present at the moment of FD button press. When pressed again (and the autopilot is not engaged) will disengage the flight director.
- HEADING (HDG) MODE SELECTOR BUTTON** - When pressed, will engage the Heading mode, which commands the airplane to turn to and maintain the heading selected by the heading bug on the HSI. A new heading may be selected at any time and will result in the airplane turning to the new heading. Button can also be used to toggle between HDG and ROL modes. This button will engage the flight director.

System Operation

6. **NAVIGATION (NAV) MODE SELECTOR BUTTON** - When pressed, will arm the navigation mode. If the selected navigation sensor is less than 50% deflected when armed, the system will automatically capture. Otherwise the capture point will vary based on needle deflection and closure rate. The mode provides automatic beam capture and tracking of VOR, LOC or GPS as selected for presentation on the HSI. NAV mode is recommended for en route navigation tracking. If pressed when NAV mode is either armed or coupled, will disengage the mode. This button will engage the flight director.

7. **APPROACH (APR) MODE SELECTOR BUTTON** - When pressed, will arm the Approach mode. If the selected navigation sensor is less than 50% deflected when armed, the system will automatically capture. Otherwise the capture point will vary based on needle deflection and closure rate. This mode provides automatic beam capture and tracking of VOR, GPS or LOC with Glideslope (GS) on an ILS, as selected for presentation on the HSI. APR ARM will annunciate. If pressed when APR mode is either armed or coupled, will disengage the mode. This button will engage the flight director. (See the NOTE following item 8).

8. **BACK COURSE APPROACH (REV) MODE SELECTOR BUTTON** - (not available when optional ED 461 EHSI installed). When pressed, will select the back course approach mode. If the selected navigation sen-

sor is less than 50% deflected when armed, the system will automatically capture. Otherwise the capture point will vary based on needle deflection and closure rate. This mode functions similarly to the approach mode except that the autopilot response to LOC signals is reversed and glideslope is inhibited. This button will engage the flight director.

NOTE: If the optional ED 461 EHSI is installed, front and back course selection is automatic and is dependent upon the relative difference between the airplane heading and the selected approach course. If the airplane heading differs from the selected course by greater than 105°, REV ARM will automatically annunciate in anticipation of tracking a localizer back course. If prior to localizer capture the heading changes (ie. during radar vectors or a procedure turn) and falls within 105° of the selected course, APR ARM will annunciate in anticipation of tracking the localizer front course.

9. **ALTITUDE HOLD (ALT) MODE SELECTOR BUTTON** - When pressed, will engage the Altitude Hold mode. The altitude maintained is the altitude at the moment the ALT button is pressed. If the ALT button is pressed with an established climb or descent rate present, there will be approximately a 10% (of VS rate) overshoot, with the airplane returned positively to the selected altitude. If pressed when ALT hold mode is engaged, will disengage the mode, defaulting to PIT mode. This button will engage the flight director.

10. **VERTICAL TRIM (UP/DN) BUTTONS** - The response of these buttons is dependent upon the vertical mode present when pressed. If PIT mode is active, successive button presses will move the pitch attitude hold reference either up or down by 0.5° per press, or at the rate of 0.8° per second if held continuously, synchronizing the pitch attitude reference to the current pitch attitude upon release. If VS mode is active, the initial button press will bring up the commanded vertical speed in the display. Subsequent immediate button presses will increment the vertical speed command either up or down at the rate of 100 ft/min per button press, or at the rate of approximately 300 ft/min per second if held continuously. If ALT mode is active, successive button presses will move the altitude hold reference altitude either up or down by 20 feet per press, or if held continuously will command the airplane up or down at the rate of 500 ft/min, synchronizing the altitude hold reference to the actual airplane altitude upon button release. (Note that neither the pitch attitude nor the altitude hold reference is displayed. The display will continue to show the altitude alerter reference.)

11. **ROTARY KNOBS** - Used to set the altitude alerter/altitude preselect reference altitude. Large (outer) knob changes reference by 1000's of feet, and the small (inner) knob changes reference by 100's of feet. When the flight director is engaged, will automatically arm a preselect altitude hold capture.

12. **VERTICAL SPEED (VS) MODE SELECTOR BUTTON** - When pressed will engage the vertical speed hold mode. The vertical speed maintained is the vertical speed present at the moment the VS button is pressed. The vertical speed command reference will initially be displayed in place of the altitude alert annunciation, defaulting back in 3 seconds to the altitude alerter value. Pressing either the UP or DN button will again cause the vertical speed command reference to be displayed while causing it to increase or decrease. When the VS button is pressed again, it will disengage the vertical speed mode. This button will engage the flight director.

13. **ALTITUDE ARM (ARM) BUTTON** - When pressed will toggle altitude arming on or off. When ALT ARM is annunciated, the automatic flight control system will capture the altitude displayed in the Altitude Alerter/Vertical Speed Display (provided the aircraft is climbing or descending to the displayed altitude). ALT ARM mode is engaged automatically whenever the selected altitude is changed via the rotary knobs. Note that the alerter functions are independent of the arming process thus providing full time alerting, even when the flight director is disengaged. This button will engage the flight director.

System Operation

14. **SELECTED ALTITUDE/VERTICAL SPEED DISPLAY** - Normally displays the selected altitude. The display indicates the reference vertical speed in FPM for 3 seconds after the CWS button or the UP or DN button is pressed and the VS mode is engaged.

15. **ALTITUDE ALERT (ALERT) ANNUNCIATION** - Illuminates as a solid alert in the region from 1000 to 200 feet from the selected altitude if the airplane was previously outside of this region. Flashes (1) for two seconds the first time the airplane crosses the selected altitude and (2) flashes continuously in the 200 to 1000 foot region if the airplane was previously inside of this region (i.e. at the selected altitude). An aural alert consisting of five short tones is associated with the visual alerting. This aural alert occurs 1,000 feet before a selected altitude while approaching it and 200 feet after leaving a selected altitude.

16. **PITCH TRIM (PT) ANNUNCIATION** - A flashing **PT** with an accompanying arrow head is an indication that the request for auto trim has lasted longer than 16 seconds. A solid **PT** without an arrowhead is an indication of a pitch trim fault. A trim runaway will generate the solid **PT** annunciation, a remote **TRIM FAIL** annunciation and a continuous alert tone. Refer to the EMERGENCY PROCEDURES in the airplane Flight Manual Supplement for proper response to a pitch trim fault.

17. **PITCH AND ROLL MODE, AUTOPILOT AND YAW DAMPER ANNUNCIATIONS** - Displays the active flight director pitch modes (PIT, VS, ALT ARM, ALT CAP, ALT, GS ARM, GS, GA, and roll modes (ROL, HDG, NAV ARM, NAV, APR ARM, APR, REV ARM, REV). Displays when the autopilot (AP) and yaw damper (YD) are engaged. Also displayed will be a flashing AP annunciation (5 seconds) at each autopilot disconnect accompanied by an aural tone (for 2 seconds).

18. **YAW DAMPER (YD) BUTTON (optional)** - When pressed will engage or disengage the yaw damper independent of autopilot operation. (The yaw damper engages automatically when the autopilot is engaged; however, the yaw damper may then be disengaged or reengaged as desired.)

19. **AUTOPILOT DISCONNECT (AP DISC/TRIM INTER) SWITCH (not shown)** - When pressed will disengage the autopilot and yaw damper if installed, and interrupt electric trim power. (Located on the left horn of the pilot's control wheel. The switch is red in color.) May also disengage the flight director depending on how the system is configured.

20. **MANUAL ELECTRIC TRIM SWITCHES (not shown)** - When both switches are pressed in the same direction, will activate pitch trim in the selected direction. If only one switch is moved, the trim system

will not operate. If one switch fails or is moved and held for 3 seconds, the trim monitoring system will detect a switch failure resulting in a PT annunciation on the autopilot display and the disabling of the electric trim system. Use of manual electric trim during autopilot operation will disengage the autopilot. (Located on the pilot's control wheel.)

21. CONTROL WHEEL STEERING (CWS) MODE BUTTON (not shown)

- When pressed and held, disengages the pitch, roll, yaw, and pitch trim clutches allowing the pilot to maneuver the airplane by hand. Pressing the CWS button will also sync the automatic flight control system PIT, ROL, ALT or VS commands to the actual attitude, altitude or vertical speed present at the time the button is released. It is not recommended to use the CWS for altitude changes greater than 400 ft. ROL will maintain wings level if CWS is released at less than 6° bank angle. (Located on the left horn of the pilot's control wheel.)

22. GO AROUND (GA) MODE BUTTON (not shown)

- When pressed will engage the flight director in a pitch up attitude and wings level (ROL mode). GA will disengage the autopilot, and cancel all armed modes including an armed altitude preselect. Lateral modes such as HDG or NAV ARM may subsequently be added. The autopilot may subsequently be engaged. Modification to the commanded pitch

attitude such as through the UP/DN button or CWS, etc. will cancel GA and revert to pitch altitude hold. (Located on the engine throttle).

23. OMNI BEARING SELECT KNOB - Selects the desired course to be tracked by the autopilot (Located on the HSI.)

24. HEADING SELECT KNOB - Positions the heading bug on the compass card (Located on the HSI.)

25. TRIM FAIL ANNUNCIATOR (not shown) - Illuminates whenever the automated preflight self-test detects a pitch trim fault or a continuous monitoring system detects a pitch trim fault in flight. (Located on the instrument panel. The annunciator is red in color.) Refer to the EMERGENCY PROCEDURES in the airplane Flight Manual Supplement for proper response to a pitch trim fault.

System Operation

Altitude Alerting and Preselect

The Altitude Preselect function allows capturing of a selected altitude and transferring into altitude hold. Manual input of selected altitude is accomplished through the rotary knobs on the faceplate of the KFC 225.

The Altitude Alerting function will visually and aurally announce approaching, acquiring and deviation from a selected altitude.

Altitude Alerter

The function of the Altitude Alerter is independent of the autopilot.

1. ALTITUDE SELECT knob - ROTATE until the selected altitude is displayed.



*Note: The **ALERT** annunciation is illuminated 1000 ft. prior to the selected altitude, extinguishes 200 ft. prior to the selected altitude and illuminates momentarily when the selected altitude is reached. Once the selected altitude is reached, a flashing **ALERT** illumination signifies that the 200 ft. "safe band" has been exceeded and will remain illuminated until 1000 ft. from the selected altitude. Associated with the visual alerting is an aural alert (five short tones) which occurs 1000 ft. from the selected altitude upon approaching the altitude and 200 ft. from the selected altitude on leaving the altitude.*



Altitude Preselect

1. ALTITUDE SELECT knob - ROTATE until selected altitude is displayed. ARM annunciation occurs automatically upon altitude selection when the flight director is engaged.



2. Airplane - ESTABLISH selected vertical speed to intercept the selected altitude.



3. Upon altitude capture, **ALT ARM** will extinguish and **ALT** will be annunciated.

Note: Glideslope coupling (but not glideslope ARM) will preclude an altitude capture on an ILS.



Voice Messaging

The following standard voice messages will be annunciated as conditions warrant:

1. **“TRIM IN MOTION, TRIM IN MOTION...”** - Pitch trim running for more than 5 seconds.
2. **“CHECK PITCH TRIM”** - An out of trim condition has existed for 16 seconds.
 - a. Airplane Control Wheel - **GRASP FIRMLY**, press **CWS** and check for an out of pitch trim condition. Manually retrim as required.
 - b. **CWS** button - **RELEASE**.
 - c. **AUTOPILOT OPERATION - CONTINUE** if satisfied that the out of trim condition was temporary. **DISCONTINUE** if evidence indicates a failure of the auto trim function.

The following optional voice messages will be annunciated if the system is configured for voice messaging:

1. **“ALTITUDE”** - 1000 feet before approaching selected altitude.
2. **“LEAVING ALTITUDE”** - 200 feet away, departing selected altitude.
3. **“AUTOPILOT”** - Autopilot has disengaged, either through pilot action or automatically.

System Operating Modes



Pitch and Roll Attitude Hold (PIT) Modes

The Pitch Attitude Hold (**PIT**) mode allows constant attitude climbs and descents. The **AP** or **FD** button engages **PIT** mode.

To operate in the **PIT** mode (with autopilot currently disengaged):

1. **FD** button - Press. Note **ROL** and **PIT** are displayed. Pressing the **AP** button will engage the autopilot in **ROL** and **PIT** modes.
2. **UP** or **DN** button - Select desired climb or descent attitude. Each button stroke will increment the pitch attitude by 0.5° . Pushing and holding the **UP** or **DN** button will cause the aircraft to pitch at 0.8° per second. Releasing the button will sync the attitude to the present pitch attitude.

To initiate a climb or descent from Altitude Hold (**ALT**) mode:

1. **ALT** button - Press. Note **ALT** changes to **PIT** referencing the present pitch attitude.
2. **UP** or **DN** button - Select desired climb or descent attitude. Each button stroke will increment the pitch attitude by 0.5° .

The **ROL** mode engages in wings level Roll Attitude Hold mode.

To change ROL Attitude Hold Mode:

1. Press **CWS** and bank the aircraft to the desired bank angle. If the bank angle is less than 6° when the **CWS** button is released, the autopilot will hold wings level. If the bank angle is greater than 6° when the **CWS** is released, the autopilot will hold the bank angle up to the maximum allowed by the autopilot for that aircraft.



Vertical Speed (VS) Mode

The Vertical Speed (**VS**) mode allows vertical speed climbs and descents. The **VS** button engages vertical speed mode.

To operate in the **VS** mode (with autopilot currently disengaged):

1. **VS** button - Press. Note **ROL**, **VS** and current vertical speed is displayed. Pressing the **AP** button will engage the autopilot in **ROL** and **VS** modes.
2. **UP** or **DN** button - Select desired climb or descent rate. Each button stroke will increment the vertical speed commanded up or down by 100 ft/min per button press, or at the rate of approximately 300 ft/min per second if held continuously.

To initiate a climb or descent from Altitude Hold (**ALT**) mode:

1. **VS** button - Press. Note **ALT** changes to **VS** and current vertical speed is displayed.
2. **UP** or **DN** button - Select desired climb or descent rate. Each button stroke will change the vertical speed commanded up or down by 100 ft/min per button press, or at the rate of approximately 300 ft/min per second if held continuously.

Note: VS command value will be displayed during Control Wheel Steering (CWS) and for three seconds following VS engagement or pressing the UP or DN button. Both altitude and vertical speed utilize the same display area. Altitude is always displayed except during vertical speed selection. If the VS command value is not displayed, pressing (and releasing) the UP or DN button will not change the indicated altitude reference but will display the VS command value.

Note: When operating at or near the best rate of climb airspeed, at climb power settings, and using vertical speed hold, it is easy to decelerate to an airspeed where continued decreases in airspeed will result in a reduced rate of climb. Continued operation in vertical speed mode can result in a stall. Pitch Attitude Hold may provide better operation at these airspeeds.



Altitude Hold (ALT) Mode

The Altitude Hold (**ALT**) mode maintains the pressure altitude acquired upon selection of altitude hold. The **ALT** button toggles between altitude hold and pitch attitude hold modes.

To operate in the **ALT** mode:

1. **ALT** button - Press. Note **ALT** is annunciated and autopilot maneuvers to maintain pressure altitude acquired at button selection.
2. **UP** or **DN** button - Select to change altitude. Button strokes will move the reference altitude by 20 feet per press, or if held continuously will command a 500 ft/min altitude change, acquiring a new reference altitude upon button release.

Note: The system incorporates automatic Baro correction capability. Any change in Baro setting will be compensated for by the autopilot to continue holding the reference altitude.

Note: When altitude hold is engaged and holding an altitude, and the AP button is depressed to disengage the AP, the system defaults to FD and ALT hold. If an altitude change is made up or down the Altitude mode must be cycled off then back on, by cycling the ALT button. If the ALT mode is not cycled and the AP is reengaged, the AP will seek the previously selected altitude.

KFC 225 Detailed System Operation

Takeoff And Climb To Assigned Altitude

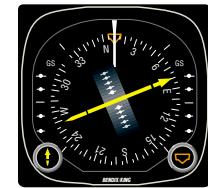
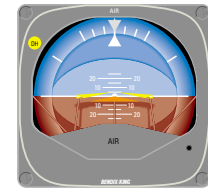
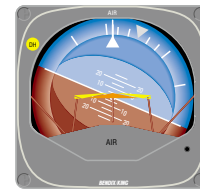
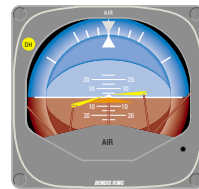
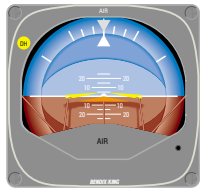

1. The aircraft is well off the ground and established at a safe climb rate.
 The heading bug on the HSI is turned to the desired heading of 080° (runway heading).
 By depressing the **HDG** button on the KFC 225, the flight director engages into the Heading and Pitch Attitude Hold modes and maintains the selected heading of 080° and current pitch attitude. Pressing the **AP** button will engage the autopilot to track these commands.

2. The heading bug on the HSI is turned to the new desired heading of 010° and the aircraft begins to respond with an immediate left turn. A cruise altitude of 7,000 feet is entered using the rotary knobs. Altitude **ARM** annunciation occurs automatically upon selection.

3. The autopilot is responding to the heading select mode with a left bank.

4. Selected altitude has been reached and automatic altitude capture occurs. The autopilot has completed the turn and is now established on a 010° heading.

GPS Capture

* Description of GPS operation based on Bendix/King GPS receiver. Others may require different operation.

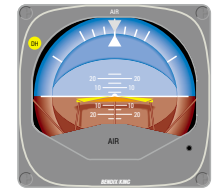
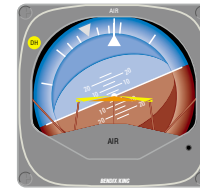
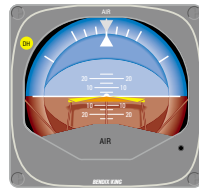
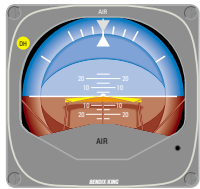
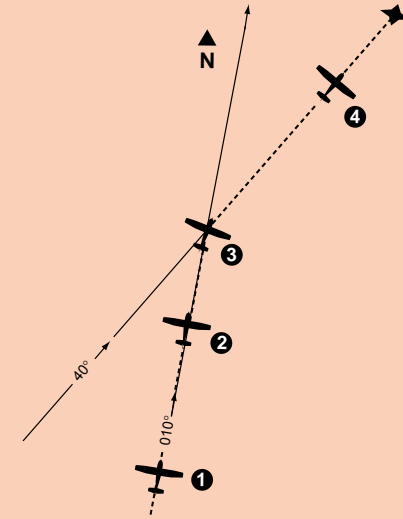

1. Continuing on heading 010°, a GPS waypoint is established. A 30° intercept is desired.

2. GPS data is selected for the HSI. The course pointer is set to 040°. The **NAV** button is depressed and **NAV ARM** is annunciated.

3. When the computed capture point is reached, the **HDG** annunciation changes to **NAV** and a right turn is initiated by the autopilot.

4. The turn is complete and the autopilot is tracking the GPS course.

Outbound On Front Course For Procedure Turn To ILS Approach

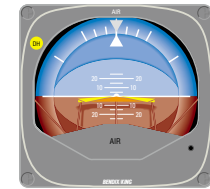
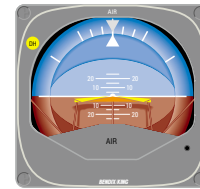
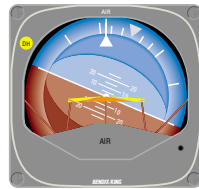
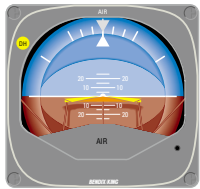
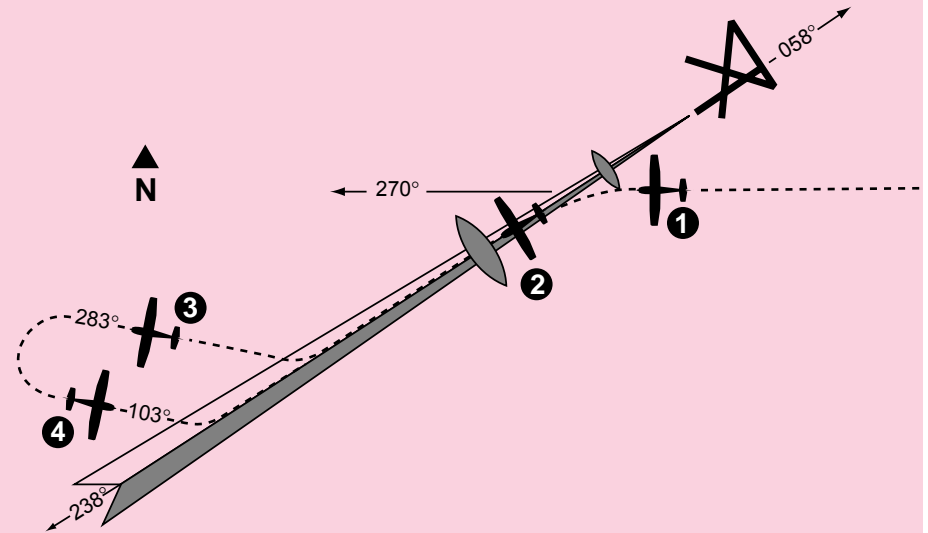

1. The aircraft is heading 270° with heading and altitude hold engaged. To intercept and fly the ILS front course outbound, set the front course on the HSI and depress the back course (**REV**) button. The back course (**REV**) mode is selected to go outbound on the front course. The capture point is now being computed based on closure rate.

2. When the computed capture point is reached, **HDG** mode is cancelled and reverse localizer mode is automatically activated and a left turn outbound on the localizer is initiated by the autopilot.

Note: The left-right deviations of the HSI course needle operate just as though you were flying a front course approach.

3. At the desired point, **HDG** mode is used to initiate the procedure turn. During the procedure turn outbound, the deviation bar shows that the aircraft is flying away from the localizer centerline at a 45° angle on a selected heading of 283°.

4. Now you have reset the heading bug to 103° and made a 180° turn to this heading. The 103° heading will intercept the front course of 058°. You must now select the approach mode by depressing the **APR** button on the KFC 225. Automatic capture of the localizer will occur.

Front Course ILS Approach

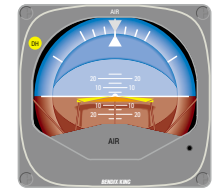
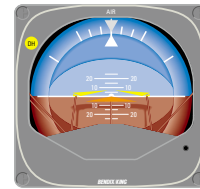
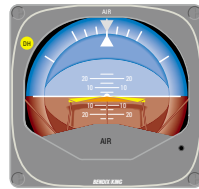
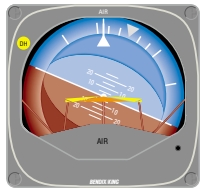
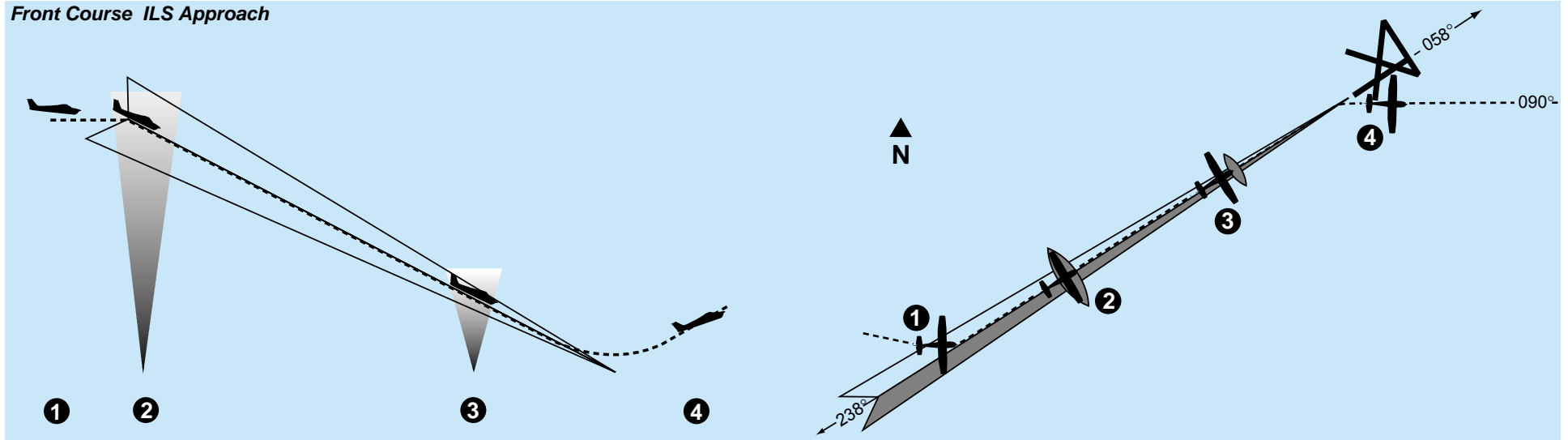

1. Continuing the Front Course for Procedure Turn to ILS Approach maneuver, APR coupling occurs (**HDG** annunciation changes to **APR**), and the glideslope mode is automatically armed. The **ALT** annunciation extinguishes and **GS** is displayed. The autopilot will capture the localizer and the CDI course index will center.

2. The autopilot is following the localizer. At the outer marker, the glideslope deviation needle is at midscale. Altitude hold is automatically disengaged when the glideslope is captured. The **ALT** annunciation extinguishes and **GS** is displayed. The autopilot will make pitch and bank changes as necessary to maintain localizer and glideslope.

3. At the middle marker, the pilot disengages the autopilot for landing, or may press the Go-Around button, also disengaging the autopilot to initiate a missed approach. This cancels **APR** and **GS** modes and engages the Flight Director in **ROL** (wings level) and **GA** (Pitch Attitude Hold) at GA pitch angle. A flashing **AP** is displayed and a disconnect tone is heard.

4. The pilot may now re-engage the autopilot. Press **HDG** to engage the heading mode to fly the missed approach. Press **CWS** and pitch the aircraft to obtain best climb. This will sync the command bars and change the annunciation to **PIT** from **GA**. Finally, pressing the **ARM** button will arm the selected altitude.

Outbound on GPS Approach

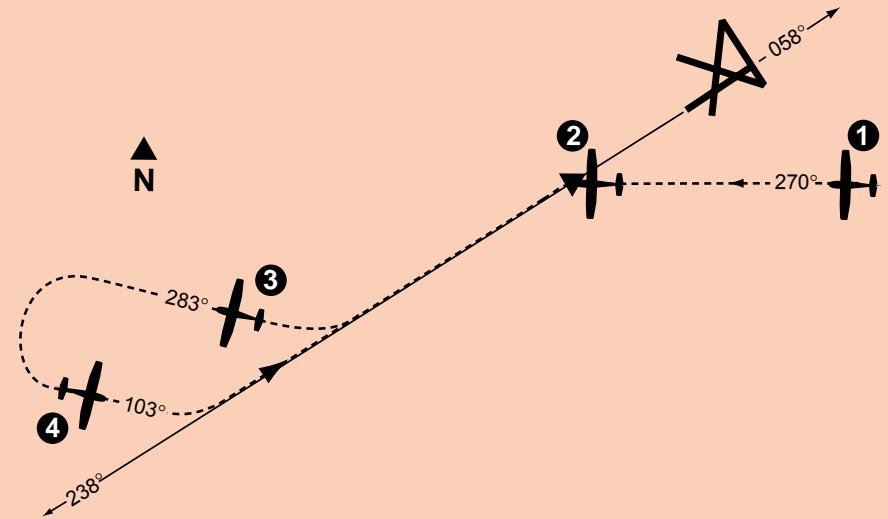

* Description of GPS operation based on Bendix/King GPS receiver. Others may require different operation.

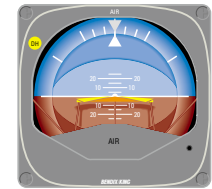
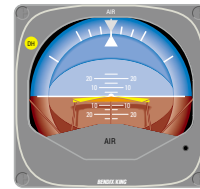
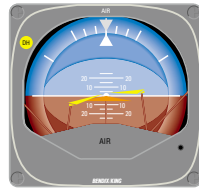
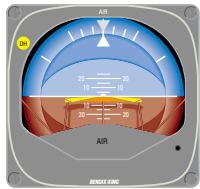

1. The aircraft is in **APR** mode approaching the IAF. Approach arm is indicated on the GPS annunciator.*

2. Upon waypoint alerting at the IAF, the course pointer is set to 238°, the GPS's Leg/OBS mode switching is set to OBS mode. The autopilot initiates a left turn to track the 238° GPS course.

3. At the desired point, heading mode is used to initiate the procedure turn. During the procedure turn outbound, the deviation bar shows that the aircraft is flying away from the GPS course at a 45° angle on a selected heading of 283°.

4. The heading bug has been set to 103° and the aircraft has made a left turn to this heading. The GPS's Leg/OBS mode switching is set to Leg mode and the course pointer is set to 058°. Select approach mode by depressing the **APR** button.

Inbound on GPS Approach

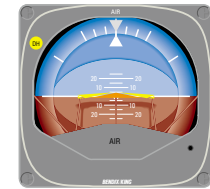
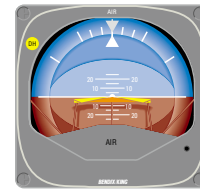
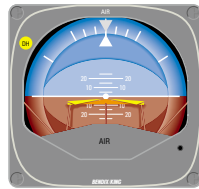
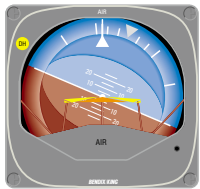
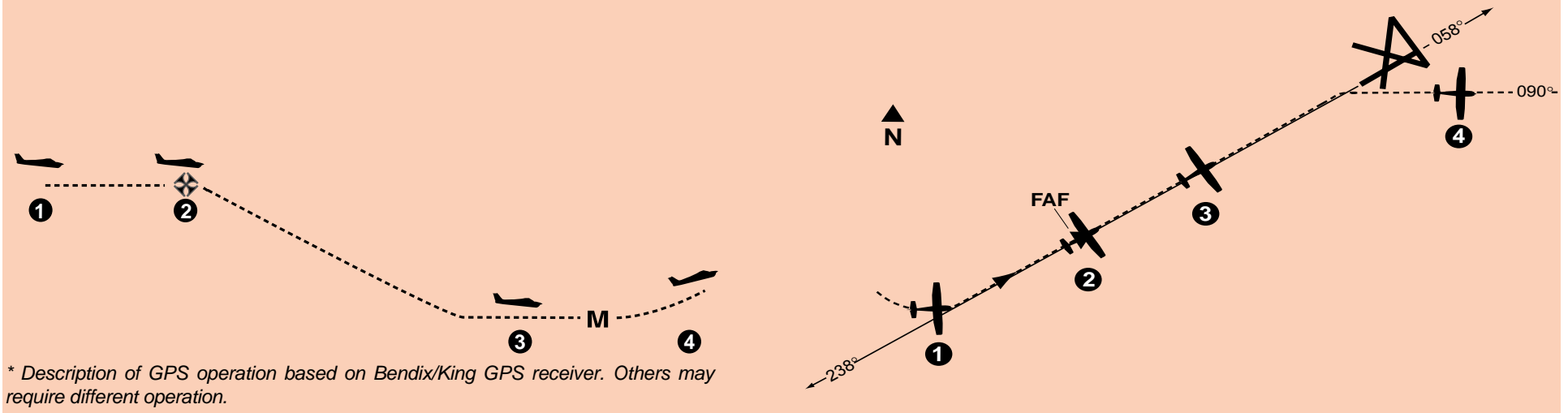

1. Continuing the Outbound on GPS Approach maneuver, **APR** mode capture occurs. The autopilot initiates a left turn to track the 058° GPS course.
* Approach active is indicated on the GPS annunciator.

2. At the FAF, **VS** is depressed to activate vertical speed mode. The desired descent rate is obtained using the **DN** button.
Remember, speed needs to be controlled with the throttle.

3. Autopilot operation is not recommended for level off at MDA. After level off, autopilot operation in **APR** or **ALT** modes may be resumed if desired. Disengage the autopilot for landing.

4. At the MAP, the pilot may press the Go-Around button, disengaging the autopilot to initiate a missed approach. This cancels **APR** and **ALT** modes and engages the flight director in **ROL** (wings level) and **PIT** (Pitch Attitude Hold) at GA pitch angle. A flashing **AP** is displayed and a disconnect tone is heard. The pilot stabilizes the aircraft in the climb and then may re-engage the autopilot.

This page intentionally left blank

KCS 55A Compass System

The KCS 55A Compass System, which includes the KA 51B Slaving Control and Compensator Unit, the KMT 112 Magnetic Slaving Transmitter and the KG 102 Directional Gyro as well as the KI 525A Pictorial Navigation Indicator is an optional part of the KFC 225 Flight Control System.

The panel-mounted KI 525A HSI combines the display functions of both the standard Directional Gyro and the Course Deviation Indicator's VOR/LOC/Glideslope information to provide the pilot with a single presentation of the complete horizontal navigation situation. This greatly simplifies course orientation, interception and tracking, while eliminating the need for scan coordination between two separate indicators.

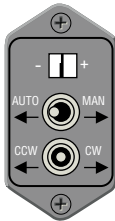

KA 51B



KI 525A

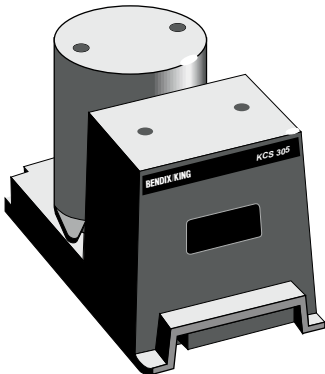

KG 102A

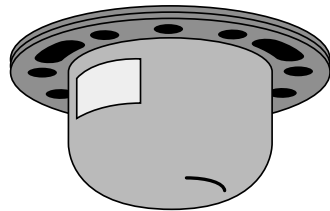

KMT 112

KCS 55A Compass System

KCS 55A Compass System

KI 525A Indicator

The KI 525A Pictorial Navigation Indicator is the panel display for the KCS 55A Compass System. It replaces the standard Directional Gyro and Course Deviation Indicator (CDI) in the aircraft's panel, combining slaved

heading and VOR/LOC/Glideslope information into one compact display. By providing a simple, comprehensive visual presentation of the aircraft's heading and position in relation to a desired course, the pilot's navigation workload is considerably reduced.

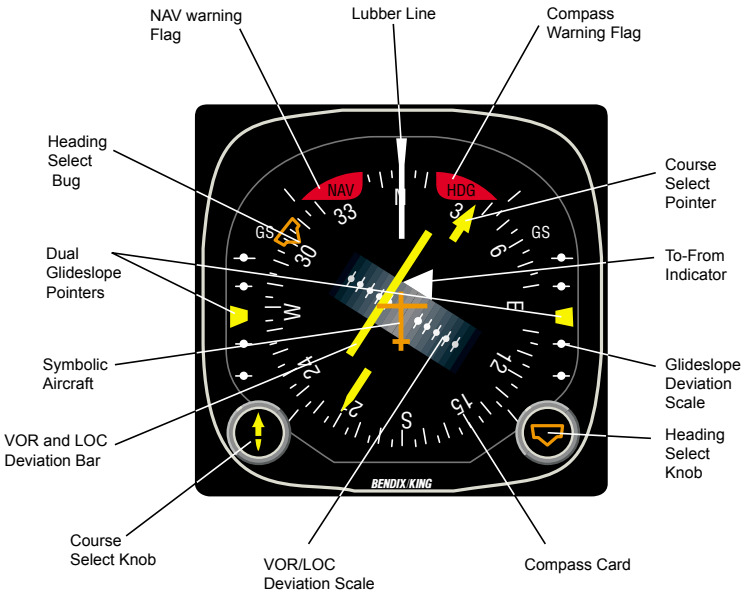

KI 525A Pictorial Navigation Indicator

Description of Indicator and Display Functions

Compass Card - Responding to the input from the slaved directional gyro, this card rotates within the display so that the aircraft heading is always at the top, under the lubber line.

Lubber Line - A fixed white marker at the top of the display that indicates aircraft magnetic heading on the compass card.

Symbolic Aircraft - A fixed representation of the actual aircraft. This miniature aircraft always points toward the top of the display and the lubber line.

Selected Course Pointer - On this two-part arrow, the “head” indicates the desired VOR or Localizer course and the “tail” indicates the reciprocal. This pointer is set by rotating the course select knob.

Course Select Knob - Used to rotate the course pointer to the desired course on the compass card. This knob corresponds to the Omni Bearing Selector (OBS) on standard NAV indicators.

VOR/RNAV and LOC Deviation - This bar corresponds to the “left/right” needle on standard course deviation indicators. When the aircraft is precisely on the VOR radial or Localizer course, it forms the center section of the selected course pointer and will be positioned under the symbolic aircraft. When off course or approaching a new course, it will move to one side or the other. Since the entire VOR and Localizer display rotates with the compass card, the angular relationship between the deviation bar and the symbolic aircraft provides a pictorial symbolic display of the aircraft’s position with respect to the selected course.

Deviation Scale - When tuned to a VOR frequency, each white dot represents two degrees of deviation left or right of course. When tuned to a Localizer, the deviation is 1/2 degree per dot. (When GPS data is selected for presentation, refer to the Pilot’s Guide for the GPS receiver.)

Heading Select Bug - A movable orange marker on the outer perimeter of the display, used primarily to select the desired heading you wish to fly. This desired heading is coupled to the KFC 225 Flight control system to provide the “Heading Select” function.

Heading Select Knob - Used to rotate the heading select bug to a desired point on the compass card.

To-From Indicator - A white triangle near the center of the display that indicates, with reference to the OBS setting, whether the course selected is “to” or “from” the selected VOR station and/or RNAV waypoint.

Dual Glideslope Pointers - Chartreuse triangular pointers on either side of the display drop into view when a usable glideslope signal is received and retract out of view when the glideslope signal becomes marginal. During an ILS approach, these pointers represent the vertical orientation of the aircraft with respect to the center of the glideslope beam. When on glideslope, the pointers will align with the center markers on the glideslope scale.

Glideslope Deviation Scale - White dots on each side of the display which, in conjunction with the glideslope pointers, indicate either “above”, “below”, or “on glideslope” during an ILS approach.

KCS 55A Compass System

Compass Warning Flag - A red flag labeled "HDG" becomes visible in the upper right quadrant of the display whenever the electrical power is inadequate or the directional gyro is not up to speed. Compass failures can occur which will not be annunciated by the "HDG" flag. Therefore, periodic comparison with the standby compass is advised.

NAV Warning Flag - A red flag labeled "NAV" becomes visible in the upper left quadrant of the display whenever a usable signal is not being received.

Slaving Meter (KA 51B)

This meter indicates any difference between the displayed heading and the magnetic heading. Right or up deflection indicates a clockwise error of the compass card. Left or down deflection indicates a counterclockwise error of the compass card. Whenever the aircraft is in a turn and the card rotates, it is normal for this meter to show a full deflection to one side or another.

NOTE: During level flight it is normal for the meter needle to continuously move from side to side and to be fully deflected during a turn. If the needle stays fully deflected, left or right, during level flight, the free gyro mode can be used to center it, as follows:

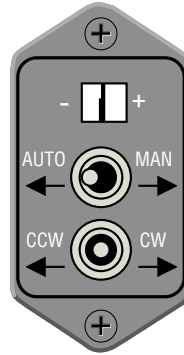

KA 51B Slaving Meter

Slave and Free Gyro Switch - When the switch is in the AUTO position, the system is in the slaved gyro mode. When the switch is in the MAN position, the system is in the free gyro mode.

Clockwise Adjustment - When the system is in the free gyro mode, holding the manual heading switch to the CW position will rotate the compass card to the right to eliminate left compass card error.

Counterclockwise Adjustment - When the system is in the free gyro mode, holding the manual heading switch to the CW position will rotate the compass card to the left to eliminate right compass card error.

The KA 51B Slaving Control and Compensator Unit is a small slaving accessory which can be used in installations where panel space is limited. The KA 51B can be mounted either vertically or horizontally.

KMT 112 Magnetic Slaving Transmitter

This unit senses the direction of the earth's magnetic field and continuously transmits this information through the slaving circuitry to the directional gyro which is automatically corrected for precession or "drift". This sensor is mounted remotely – usually in a wingtip – to eliminate the possibility of magnetic interference.

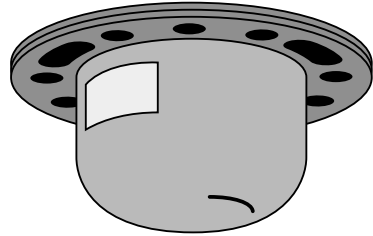

KMT 112 Magnetic Slaving Transmitter

KG 102A Directional Gyro

The directional gyro provides gyro stabilization for the system and contains the slaving circuitry necessary for operation of the system. Power may be for either 14 or 28 volts DC. This sensor is also remote mounted.

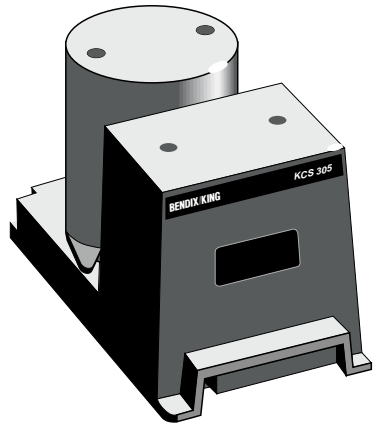

KG 102A Directional Gyro

Operating Instructions

1. Until power is applied to the KCS 55A System, and the directional gyro is up to speed, a red flag labeled "HDG" will be visible in the upper right quadrant of the KI 525A Indicator. In operation, this warning flag will be visible whenever the power being supplied is inadequate or the gyro is not up to speed.
2. With the application of power to the KCS 55A System, and gyro up to operating speed, the red "HDG" flag should disappear from view.
3. If the KCS 55A System is in the slaved gyro mode, the compass card will automatically fast slave at the rate of 180 degrees per minute toward the aircraft's magnetic heading. (Immediately after applying power, this compass card movement should be quite visible.) It will continue to fast slave until the proper magnetic heading is indicated, after which it will slave at a constant rate of three degrees per minute to keep the system aligned with the earth's magnetic field.

KCS 55A Compass System

- Under some conditions it is possible for the system to stop slaving exactly 180 degrees from the correct heading. If this should occur, move the "Slave" switch on the KA 51B to the unslaved (free) position. Rotate the compass card ± 10 degrees from the incorrect heading by using the manual rotation switch and then return the system to slaved operation. The system will then slave to the correct heading.
4. For the free gyro operation, check the magnetic compass to determine the correct magnetic heading. Then use the manual slave switch to align the system with the earth's magnetic field. Periodic checks with the standby compass are recommended to check and correct for gyro precession.
 5. Until a usable navigation signal is being received by the NAV system, a red flag labeled "NAV" will be visible in the upper left quadrant of the KI 525A Indicator. In operation, this warning flag should be visible whenever an inadequate navigation signal is being received.
 6. For normal navigation to or from a VOR or VORTAC, set the NAV receiver to the desired VOR or VORTAC frequency and the red navigation flag (NAV) should disappear from view if a usable signal is being received.
 7. Rotate the course select knob to position the course pointer to the desired VOR course.
 8. The VOR deviation bar represents the selected course, and the relationship of this bar to the symbolic aircraft in the center of the instrument visually presents the actual relationship of the selected course to your aircraft heading. (In other words, if the symbolic aircraft on the display indicates approaching the deviation bar at 45 degrees, that is the angle at which your aircraft is actually approaching the selected course.
 9. To prepare for an ILS approach, tune the NAV receiver to the desired Localizer frequency. If a usable Localizer signal is being received, the NAV warning flag will disappear.
 10. For a front or back course approach, rotate the course select knob to set the course pointer on the inbound Localizer course. As with normal navigation (#6 above), the LOC deviation bar represents the desired course. The relationship between this bar and the symbolic aircraft gives a true picture of your aircraft's position with respect to the Localizer course. Always setting the course pointer to the inbound Localizer course provides the correct deviation bar sensing whether flying a front or back course approach.
 11. The glideslope deviation pointers should become visible on both sides of the display when a usable glideslope signal is received. If they do not come into view, a usable glideslope signal is not being received.

12. The glideslope pointers indicate the relative position of the glideslope path with respect to the aircraft. (In other words, if the pointers are above the center marker, the aircraft is below the glideslope.)

Abnormal Circumstances

If the Warning Flag (HDG) appears during operation, the compass card indications will be in error. Power may be removed from the KG 102A Directional Gyro by pulling the appropriate circuit breaker. The Selected Course, VOR/LOC Deviation Bar, the NAV flag, and the To/From Indicator will remain in operation.

If the Navigation Warning Flag (NAV) appears during operation, there are several possibilities: (1) the NAV receiver is not turned on, (2) the NAV receiver is improperly tuned, (3) the ground VOR or LOC station is malfunctioning, (4) the aircraft is out of range of the selected ground station, or (5) the aircraft NAV receiver has malfunctioned. (The compass card will continue to display the aircraft heading even if a usable NAV signal is not being received.)

If the glideslope pointers remain out of view during a front course ILS approach, wither the aircraft glideslope receiver or the ground station glideslope transmitter is malfunctioning. Glideslope is usually not available during a back course approach. (The VOR and LOC course display will continue to

function normally even if a usable glideslope signal is not being received.)

A continuous large deflection of the slaving meter or large discrepancies between the magnetic compass and the KI 525A compass card may indicate a failure in the slaving system. If a slaving failure should occur, the Slave/Free Switch should be moved to select the free gyro mode. Then, by using manual clockwise or counterclockwise corrections, the compass can be rotated to the correct heading as indicated on the standby compass. The KCS 55A system should continue to function normally except the heading information will be solely derived from the KG 102A Directional Gyro. There will be no automatic heading correction and periodic adjustments must be made manually to correct for precession by reference to the standby magnetic compass, as with any directional gyro.

Note: It is desirable to disconnect the autopilot under the following conditions:

1. HDG flag comes into view.
2. System is in fast slave.
3. During manual slaving.

The system has the capability to supply the autopilot with an automatic disconnect signal under these conditions.

Note: For system limitations in your particular aircraft type, refer to your Flight Manual Supplement.

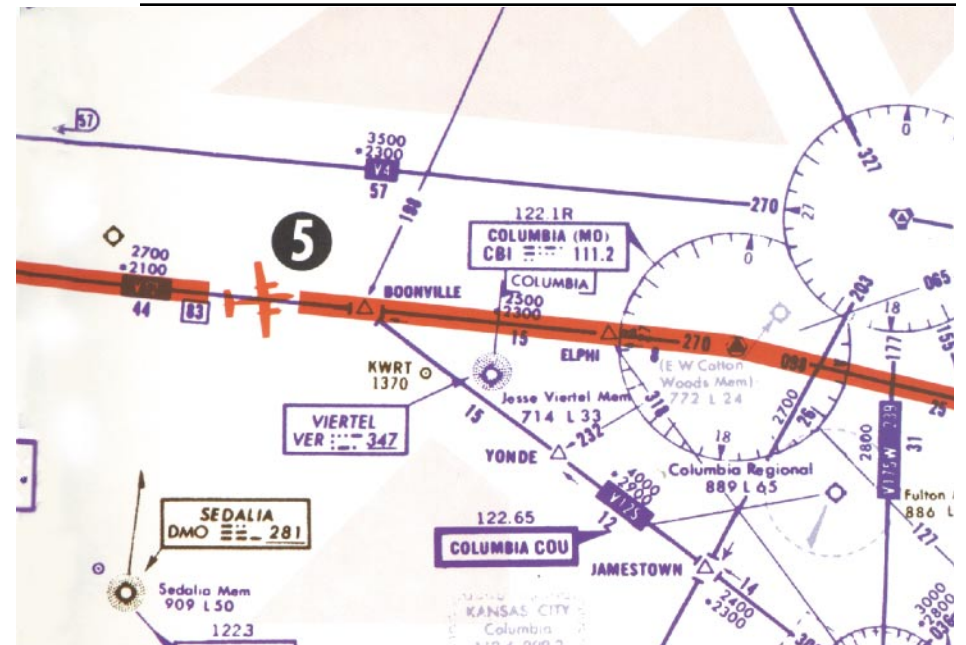
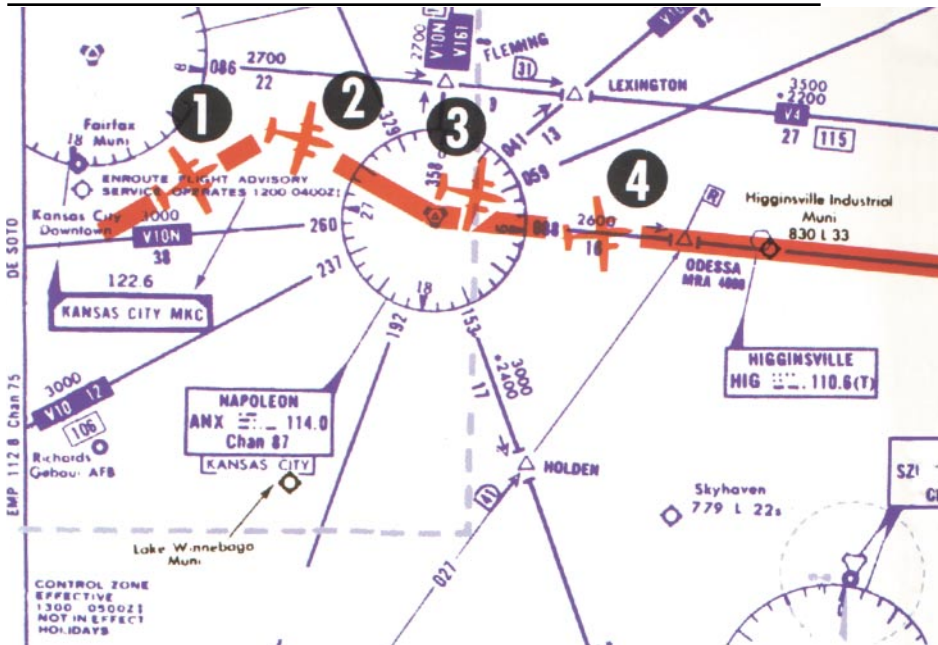

Flight Procedures with the KCS 55A

The next few pages depict a normal flight departure from MKC enroute to STL via Victor Airway V-12. (The charts shown here are for illustration purposes only, not to be used for navigation.) Careful study of these illustration of the KI525A HSI should give you a better idea of how simple and comprehensive the display is.



1. Vectors to Intercept a Radial

After takeoff from Kansas City, we select a heading of 060° with the heading bug to intercept the 110° course to Napoleon (ANX) VOR. Selected course pointer is set on 110° with the course knob. The KI 525A HSI conveniently and accurately displays the intercept angle.



2.

The VOR deviation bar begins to center as we approach the 110° course to Napoleon. The KI 525A HSI makes it possible to intercept the course smoothly, without overshooting or bracketing. One method of doing this is to adjust your heading so that the top of the deviation bar always touches the lubber line. As your aircraft heading approaches the new course, the deviation bar will swing towards the center and the angle of intercept will decrease.



3. Turn to Intercept a Victor Airway

The "TO" indicator starts to swing to "FROM" as you fly over the Napoleon VORTAC station. At this time, set the selected course pointer on the V-12 course of 088°.

As you begin your left turn to track V-12, notice that the KI525A HSI continuously displays an accurate picture of the relationship between your aircraft and the ANX 088 radial.

Once again, you can make a precise, coordinated course interception by adjusting your heading to keep the top of the deviation bar touching the lubber line.

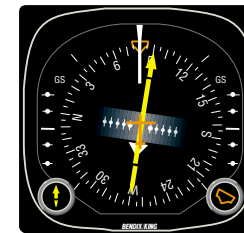

4.

When the deviation bar is centered and aligned with the course arrow, you are on course. Notice that correction for wind drift - in this case, a 080° heading on a 088° course - is completely automatic as long as you keep the deviation bar centered.



5.

About midway between Napoleon and Columbia (CBI), you switch to the CBI VOR and the TO/FROM indicator immediately swings to "TO". Also note the course arrow should be moved from 088° to 090° which is the V-12 inbound course to CBI.

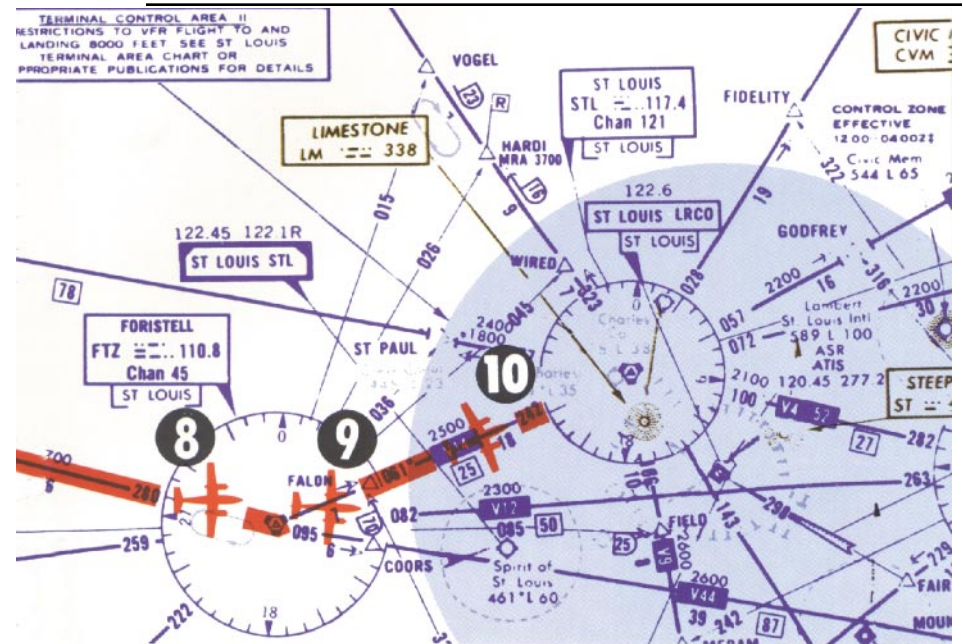
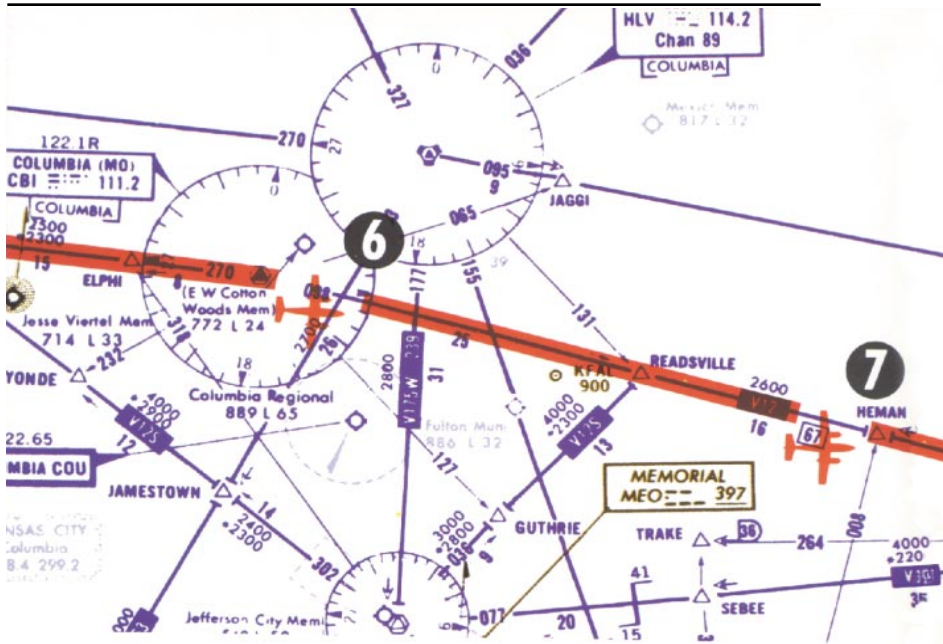

6. As you fly over the Columbia station, the TO/FROM indicator changes to "FROM". Since the outbound course for V-12 from Columbia to Foristell (FTZ) is 098°, you now set the selected course pointer on 098° and fly to keep the deviation bar centered.



7. Near the Herman intersection you switch to Foristell VORTAC and move the course arrow to 100°, which is the V-12 inbound course to FTZ. The TO/FROM indicator changes to "TO".



8. Airway Interception
Your clearance is V-12 to Foristell, then V-14 to the St. Louis (STL) VORTAC, direct Lambert Field. Approaching the FTZ station, the heading bug is on 100° as a reference for the V-12 course or as heading command for the autopilot, if used. Select the St. Louis VORTAC on the NAV receiver and set the course pointer on the STL 062° course.



9. As you cross the Foristell VORTAC, the deviation bar will align with the course arrow. Now set the heading bug to 062° and turn left to follow V-14 to the STL VORTAC.



10. You are now established on V-14, flying to the STL VORTAC. Once again, if you fly to keep the deviation bar centered, correction for wind drift will automatically be accomplished.

Note: For system limitations refer to your Flight Manual Supplement.

HOLDING PATTERN

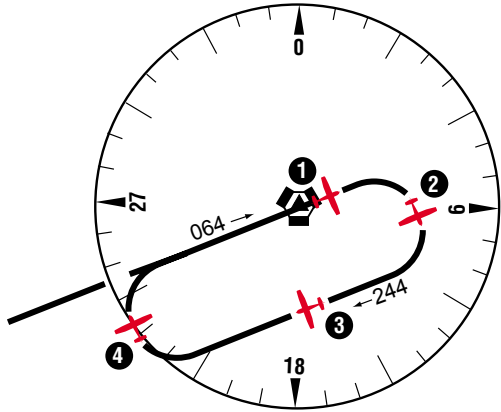

1. Approaching the STL VORTAC, the controller asks you to hold southwest of the VORTAC on the 244° radial, right turns. You are now over the station with a 064° course selected (the TO/FROM indicator has swung to "FROM"). Set your heading bug to the reciprocal or outbound heading of 244° for easy reference and begin your right turn holding pattern.



2. Halfway through the outbound turn, the KI 525A display shows the deviation bar behind the symbolic aircraft. You know, therefore, that you must eventually fly back to the radial in order to be on course during the inbound leg of the holding pattern.



3. Outbound, you are using the heading bug as reference for 244°. The 244° radial is off the right wing and parallel to your outbound course.



4. Halfway through your turn to the inbound 064° course, the KI 525A shows the symbolic aircraft approaching the deviation bar at a right angle. By keeping the top of the deviation bar on the lubber line, you can complete your turn and roll out precisely on course.

Note: For system limitations refer to your Flight Manual Supplement.

**ILS APPROACH-
FRONT COURSE**

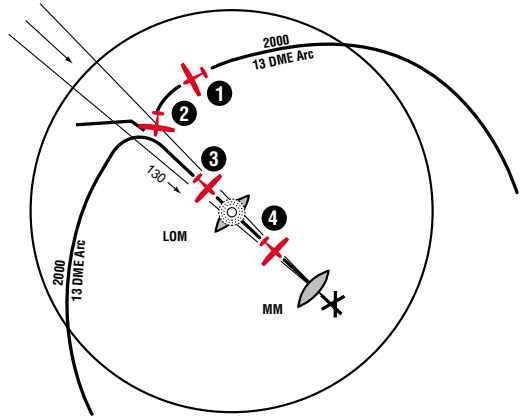

1. You are vectored from the holding pattern to the 13 DME arc. The aircraft is turning, with the heading bug set on 170° to intercept the localizer. You have already set the selected course pointer on the inbound ILS course 130° and the KI 525A shows the localizer course is directly ahead. The glideslope pointers came into view when the ILS frequency was tuned, since a usable glideslope signal is being received.



2. Capturing the ILS course can be accomplished without overshooting or bracketing with the same technique you used in intercepting an enroute course. Simply keep the top of the deviation bar on the lubber line and coordinate your turn until the bar is centered with the course arrow. Each dot on the LOC deviation scale represents 1/2 degree of deviation when tuned to an ILS frequency.



3. The KI 525A shows you that you have intercepted the localizer course. The glideslope pointers have started to center, although the display indicates your aircraft is still below the glidepath at this point.



4. You are now centered on the localizer and the glideslope. Once again, the KI 525A shows your aircraft is crabbed about 5° to the right to maintain the localizer course.

Note: For system limitations refer to your Flight Manual Supplement.

BACK COURSE APPROACH - (REV)

If a back course approach is required, it can be accomplished as easily as a front course approach. The course arrow should always be set on the front course inbound localizer course. This will result in conventional pictorial deviation sensing even on back course. The KI 525A display gives you an accurate picture of where you are at all times during the approach and procedure turn.

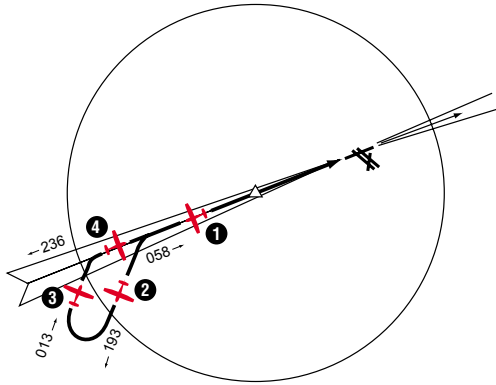

1. You are outbound on the back localizer course, having already set the course pointer to the inbound front course at 238°. The heading bug is preset at 193° for the procedure turn. (Since there is usually no glideslope signal on a back course, the glideslope pointers are out of sight.)



2. During the procedure turn outbound, the deviation bar shows pictorially that the aircraft (as represented by the symbolic aircraft in the center of the KI 525A) is flying away from the localizer centerline at a 45° angle when the heading bug is under the lubber line. Note that left-right deviations of the course bar give "fly-to" indicators, just as on the front course.



3. Now you've reset the heading bug to 013° and made a 180° turn to this heading. This 013° heading will intercept the back course. The KI 525A clearly pictures the course you are to intercept and the angle of interception.



4. You have smoothly intercepted the back course. Since the course arrow is set on the front course (238°), the KI 525A shows a true picture of the situation - flying inbound on the back course. You may reset the heading bug to 058° for easy reference.

Note: For system limitations refer to your Flight Manual Supplement.

General Emergency Procedures

Autopilot Malfunction

An autopilot, autopilot trim or manual electric trim malfunction may be recognized as an uncommanded deviation in the airplane flight path or when there is abnormal control wheel or trim wheel motion. The primary concern in reacting to an autopilot or trim malfunction, or to an automatic disconnect of the autopilot, is in maintaining control of the airplane. Immediately grasp the control wheel and press and hold down the A/P DISC/TRIM INTER switch throughout the recovery. Manipulate the controls as required to safely maintain operation of the airplane within all of its operating limitations.

CAUTION: Refer to the *Airplane Flight Manual* or the *Airplane Flight Manual Supplement* for your particular aircraft for pertinent emergency procedures.

This page intentionally left blank

Honeywell International Inc.
One Technology Center
23500 West 105th Street
Olathe, Kansas 66061
FAX 913-791-1302
Telephone: (913) 712-0400

006-18035-0000

Rev. 1 9/04

Honeywell