

# 3GNSSX-XX-X

## FRPA footprint multi-frequency GNSS antenna

The 3GNSSX-XX-X is a multi-frequency antenna for assured positioning, navigation and timing (APNT) reception. This wideband antenna operates across GPS, GLONASS, Galileo and BeiDou frequencies for true Global Navigation Satellite System (GNSS) reception.

The baseplate is compatible with standard Fixed Reception Pattern Antenna (FRPA) mounting holes for easy installation onto new and existing platforms. An O-ring seal is included on the antenna base to ensure sealing between the antenna and the platform.

The product family is available in passive and active (amplified) configurations. The active circuitry is designed to support a wide range of input voltages with low current consumption. The passive design is ideal for installations where the antenna is located close to the receiver.

Antcom can customize this product family to meet your specific requirements. Please contact us for more information about customization options.

### Options

#### Color

- Gloss white
- Lusterless gray
- Camo green
- Lusterless black
- Desert tan

#### Connector

- SMA
- TNC
- Type N
- TNC Bulkhead

#### LNA Gain

- 33 dB
- Passive



### Benefits

- Standard FRPA mount for easy installation
- Multi-frequency GNSS coverage for assured PNT

### Features

- Maximum multi-frequency, multi-constellation coverage
- FRPA compatible mounting holes and footprint
- Passive or active (amplified) configurations available
- DC power input through RF connector
- Connector options available
- Paint color options available

**Electrical**

**Frequency range**

GLONASS L1	1598.06-1609.31 MHz
GPS L1, Galileo E1, BeiDou B1	1575.42 ± 15 MHz
L-Band correction	1539-1559 MHz
GLONASS L2	1242.94-1251.69 MHz
GPS L2	1227.60 ± 15 MHz
Galileo E5b, BeiDou B2/B2b	1207.14 ± 10.23 MHz
GPS L5, Galileo E5a, BeiDou B2a, Navic L5	1176.42 ± 12 MHz

**VSWR** <2.0:1

**Impedance** 50 ohms

**Polarization** RCHP

**Mechanical and environmental**

Designed to:

**Weight** 12.4 oz (typical)

**Temperature** -55°C TO +85°C

**Altitude** 70,000 ft

**Vibration** > 30 Grms

**Typical LNA performance**

**LNA gain** See Options table

**LNA noise figure** 3.5 dB

**LNA P1dB out** +8 dBm

**LNA DC power** (2.7 - 15) V  
<40 mA

**Limiting and filtering**

**Power handling** 1 Watt CW

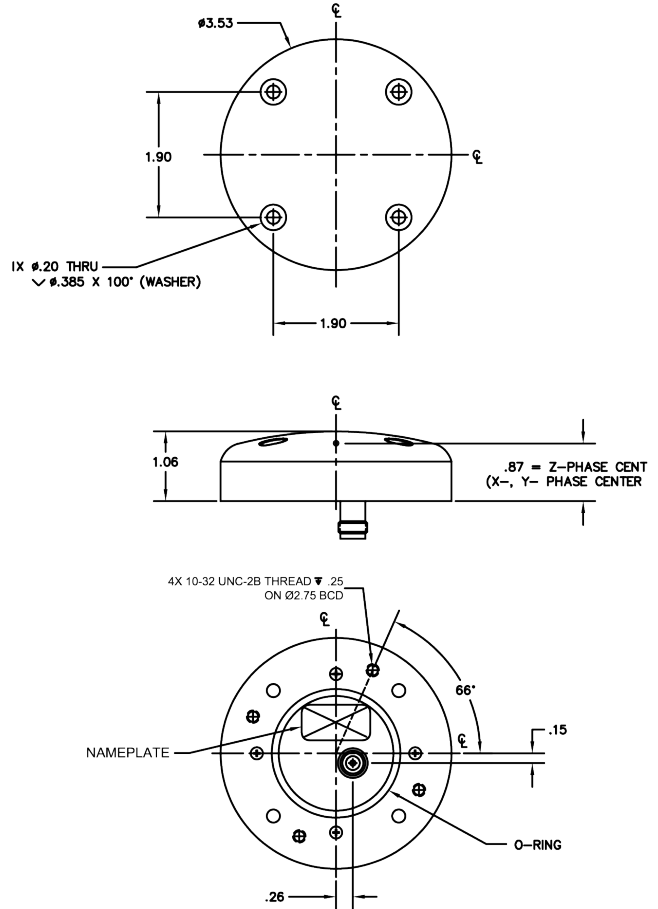

**Part number decoder**

**3GNSSX-XX-X**



Contact Hexagon | Antcom

sales.ant.ap@antcom.com | Phone: 1-310-782-1076 | Fax: 1-310-782-1086.

For the most recent details of this product: antcom.com

*This document and the information contained herein are provided AS IS and without any representation or warranty of any kind. All warranties, express or implied, are hereby disclaimed, including but not limited to any warranties of merchantability, non-infringement, and fitness for a particular purpose. Nothing herein constitutes a binding obligation. The information contained herein is subject to change without notice. Antcom is a trademark of Hexagon AB and/or its subsidiaries and affiliates, and/or their licensors. All other trademarks are properties of their respective owners.*

*© Copyright 2021 – 2023 Hexagon AB and/or its subsidiaries and affiliates. All rights reserved. A list of entities within the Hexagon Autonomy & Positioning division is available at <https://hexagon.com/company/divisions/autonomy-and-positioning>.*